

RF Coaxial IDC

00-6791



Designed to simplify the connection process, the new 6791 series wire to board connectors for coaxial cables enable simple termination with one press. Expanded the proven-reliable IDC (Insulation displacement connector) from signal/power transmission to high frequency transmission field up to 6Ghz, the IDC contact pierces the jacket and insulation of the cable and makes direct contact with the strands and conductor of the wire at the same time. Comparing with direct soldering the soldering quality is no more depending on operator's skill which is hard to be unified and controlled. Hand soldering is now not preferred/allows in automotive field. Comparing with costly traditional 2-piece solution which is generally taller than 10mm, the new 6791 Series offers a cost-effective solution and the on board height in less than 5mm after the cap is pressed. Process to prepare coaxial cable with a 2-piece connector is time consuming and costly, with the launch of the new 6791 series the process is now simplified and the cost is reduced.

APPLICATIONS

- The connector comes in multiple types for different coaxial cables.
- Small package size and mechanical strength allows usage in automotive and industrial antenna applications
- Reference Application Notes 201-01-214

FEATURES AND BENEFITS

- Can replace costly traditional RF connector systems.
- Good RF performance up to 6GHz.
- Mechanically strong with peel off force up to 70N
- Easy assembly process with ability to automate.

ELECTRICAL

- Current Rating: 0.5 Amps
(Current limit is cable dependent)
- Voltage Rating: 125Vac

ENVIRONMENTAL

- Operating Temperature:
-40°C to +105°C

MECHANICAL

- Insulator Material: Glass-Filled Nylon 46; UL94V-0
- Contact Material: Copper Alloy
- Plating: Lead-Free Tin Over Nickel

HOW TO ORDER

00 **6791** **001**
 | | |
 Prefix Series No. of Ways
 001 = 1

00X
 |
 Cable Size*
 001 = 50Ω: Outer Jacket 2.33mm-2.60mm
 003 = 50Ω: Outer Jacket 2.70mm-3.10mm

005
 |
 Plating



See comparison of cable dimensions in below chart

IDC COAX CABLE SIZE

Component	Diameter (mm)			
	-001		-003	
	Lower Limit	Upper Limit	Lower Limit	Upper Limit
Conductor	0.43	0.54	0.46	0.57
Dielectric	1.44	1.68	1.45	1.70
Braid Shield	1.84	2.08	1.85	2.10
Jacket	2.33	2.60	2.70	3.10

RF Coaxial IDC

00-6791

00 6791 001 001 005

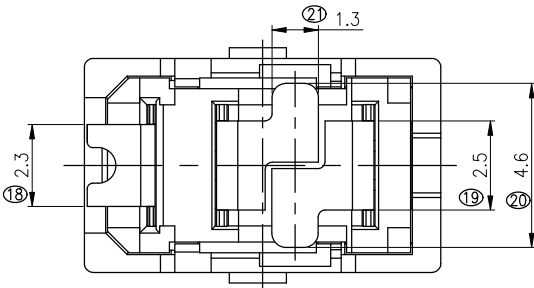
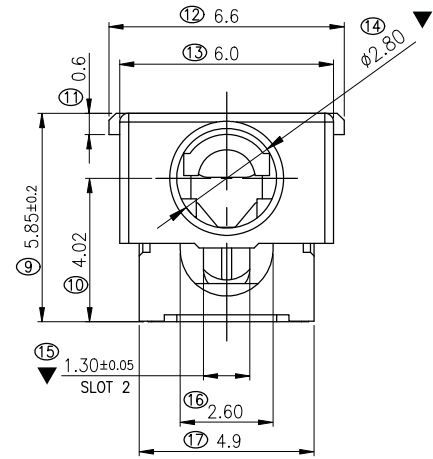
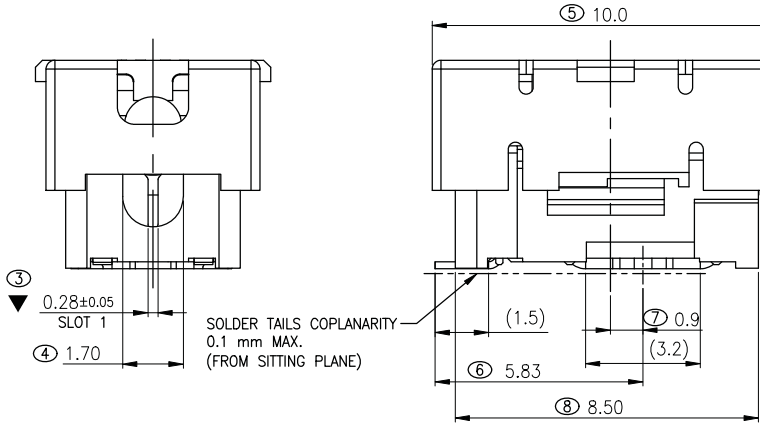
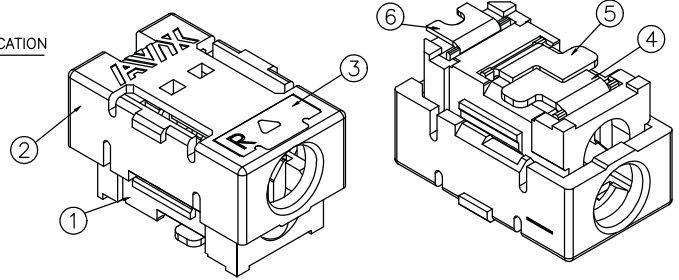
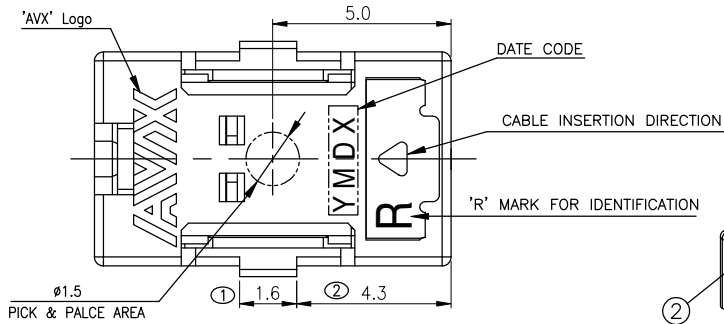

NOTES:

- VOLTAGE RATING: 125V
- OPERATING TEMPERATURE: -40°C TO +105°C
- FOR REFLOW SOLDERING LEAD-FREE PROCESS.
- SOLDERING HEAT RESISTANCE REFLOW SOLDERING 260°C.
- RECOMMENDED PRESSING STOP HEIGHT AS 3.75±0.05mm.
- ALLOW CABLE INSERT TOLERANCE.: 0.3mm MAX.
- CRITICAL DIMENSION : ▼

⑥	SIGNAL CONTACT	PHOSPHOR BRONZE C5191-H	Tin OVERALL, NICKEL UNDERPLATED HADRNESS : HV180~230	1	
⑤	BRAID CONTACT(2)	PHOSPHOR BRONZE C5191-H	Tin OVERALL, NICKEL UNDERPLATED HADRNESS : HV180~230	1	
④	BRAID CONTACT(1)	PHOSPHOR BRONZE C5191-H	Tin OVERALL, NICKEL UNDERPLATED HADRNESS : HV180~230	1	
③	SUPPORT PLATE	SUS304-H	ULTRASONIC CLEANING HARDNESS: HV370~400	1	
②	CAP	PA-46, TS200F6	UL94HB,BLACK	1	
①	HOUSING	PA-46, TS200F6	UL94HB,BLACK	1	
ITEM	DESCRIPTION	MATERIAL	FINISH	Q'TY	NOTE

CONSTRUCTION

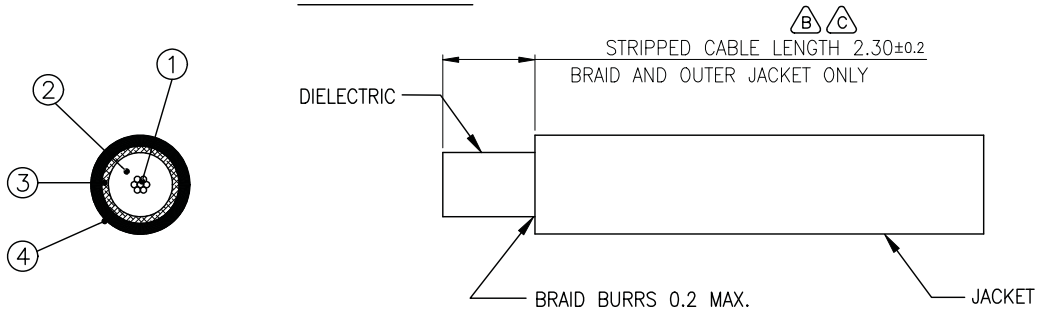

NOTE: JACKET STRIP OD DEFORMED MUST BE THAN LESS $\varnothing 2.75\text{mm}$ AFTER CUT OFF.

$\triangle D$ APPLICABLE COAXIAL CABLE DIMENSIONS:

COMPONENT	DIAMETER (mm)	
	LOWER LIMIT	UPPER LIMIT
(1) CONDUCTOR	$\varnothing 0.43$	$\varnothing 0.54$
(2) DIELECTRIC	$\varnothing 1.44$	$\varnothing 1.68$
(3) BRAID SHIELD	$\varnothing 1.84$	$\varnothing 2.08$
(4) JACKET	$\varnothing 2.33$	$\varnothing 2.60$

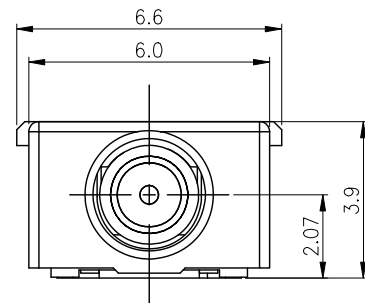
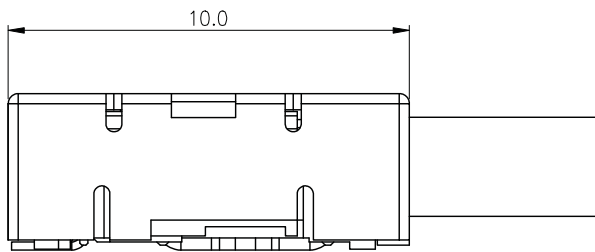
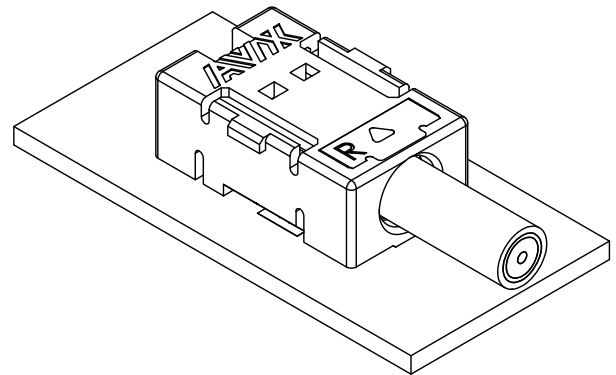

WIRED CONNECTOR

RF Coaxial IDC

00-6791

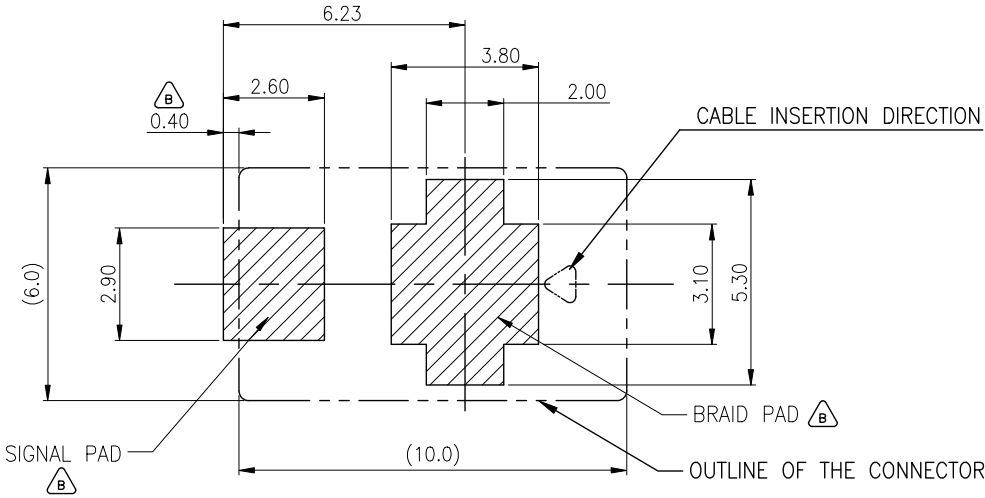

RECOMMENDED PCB LAYOUT

RF Coaxial IDC

00-6791

00 6791 001 003 005

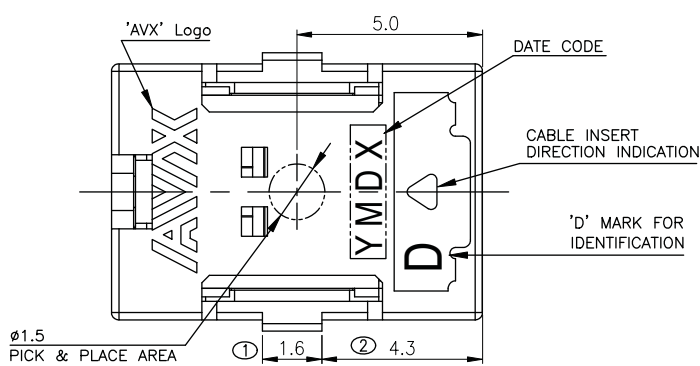

DATE CODE:
 Y M D X
 X:LINE
 D:DAY(1~9,A=10,B=11 ~ U=30,V=31)
 M:MONTH(1~9,X=10,Y=11,Z=12)
 Y:YEAR(0~9)

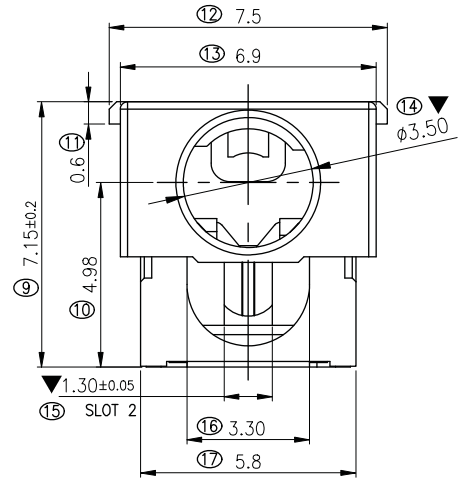
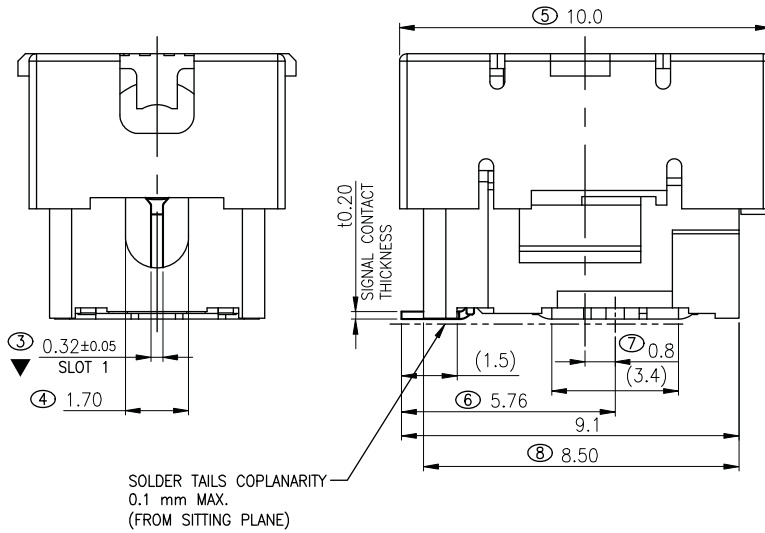
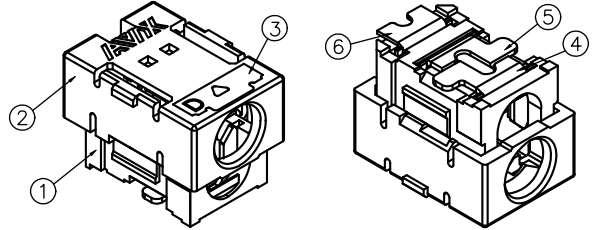

NOTES:

1. VOLTAGE RATING: 125V
2. OPERATING TEMPERATURE: -40°C TO +105°C
3. FOR REFLOW SOLDERING LEAD-FREE PROCESS.
4. SOLDERING HEAT RESISTANCE REFLOW SOLDERING 260°C.
5. RECOMMENDED PRESSING STOP HEIGHT AS 4.35±0.05mm.
6. ALLOW CABLE INSERT TOLERANCE.: 0.3mm MAX.
7. CRITICAL DIMENSION : ▼

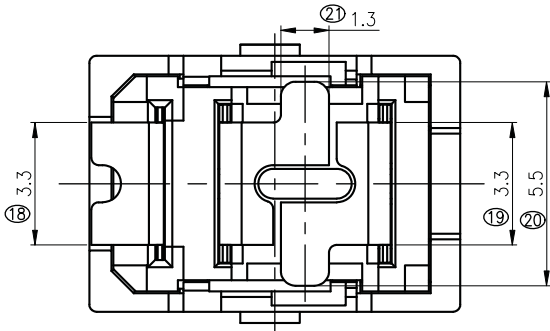

⑥	SIGNAL CONTACT	PHOSPHOR BRONZE C5191-H	Tin OVERALL, NICKEL UNDERPLATED HADRNESS : HV180~230	1	
⑤	BRAID CONTACT(2)	PHOSPHOR BRONZE C5191-H	Tin OVERALL, NICKEL UNDERPLATED HADRNESS : HV180~230	1	
④	BRAID CONTACT(1)	PHOSPHOR BRONZE C5191-H	Tin OVERALL, NICKEL UNDERPLATED HADRNESS : HV180~230	1	
③	SUPPORT PLATE	SUS304-H	ULTRASONIC CLEANING HADRNESS: HV370~400	1	
②	CAP	PA-46, TS200F6	UL94HB,BLACK	1	
①	HOUSING	PA-46, TS200F6	UL94HB,BLACK	1	
ITEM	DESCRIPTION	MATERIAL	FINISH	Q'TY	NOTE

RF Coaxial IDC

00-6791

CONSTRUCTION

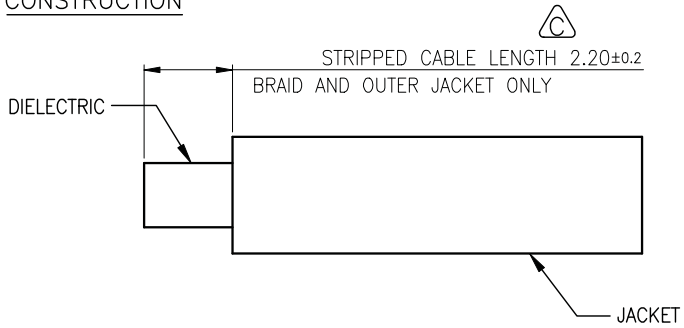
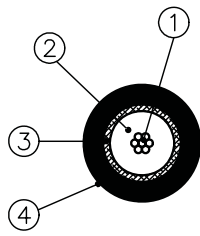

NOTE: JACKET STRIP OD DEFORMED MUST BE THAN LESS $\phi 3.30\text{mm}$ AFTER CUT OFF.

APPLICABLE COAXIAL CABLE DIMENSIONS:

COMPONENT	DIAMETER (mm)	
	LOWER LIMIT	UPPER LIMIT
(1) CONDUCTOR	$\phi 0.46$	$\phi 0.57$
(2) DIELECTRIC	$\phi 1.45$	$\phi 1.70$
(3) BRAID SHIELD	$\phi 1.85$	$\phi 2.10$
(4) JACKET	$\phi 2.70$	$\phi 3.10$

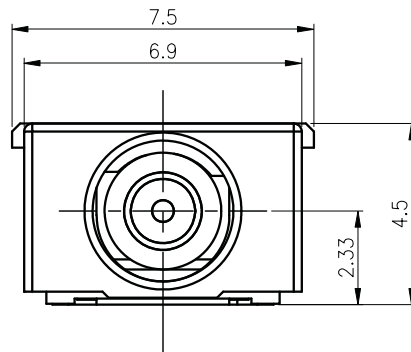
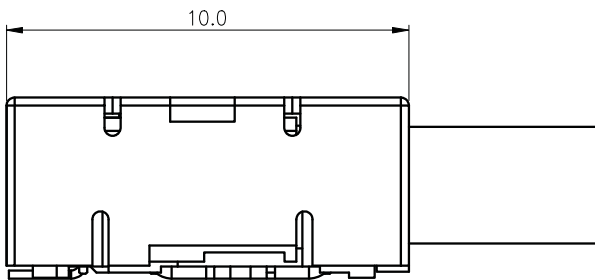
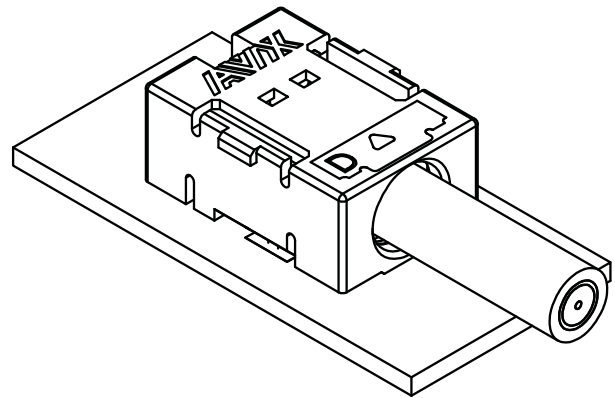

WIRED CONNECTOR