

GCD Series – DC Operated Gage Heads



- Hermetically sealed housing
- 25 μ -inch [0.6 μ m] repeatability
- IEC IP68 rating to 1,000 PSI [70 bars]
- Long strokes up to ± 2 inches
- Hardened tool steel contact tip
- High side load resistance
- Long cycle life

DESCRIPTION

The **GCD Series** heavy-duty DC operated gage heads enable high performance in environments containing moisture, dirt, and fluid contaminants. These Gage heads are spring loaded LVDTs (Linear Variable Differential Transformers) with precision linear bearings and internal conditioning electronics. Operating on a nominal ± 15 VDC supply, the GCD Series delivers an extremely linear, low noise ± 10 VDC output.

These robust gage heads allow measurements over stroke ranges from ± 0.05 inch [± 1.27 mm] up to ± 2 inches [± 50.8 mm]. The spring force is typically 9oz [255 grams] at fully compressed electrical stroke. A removable black-chromed, hardened tool steel tip is threaded (4-48UNF-2A) to the working end. Internal construction prevents the core and shaft from rotating as they move longitudinally. The integral electrical connector (welded) provides for easy installation and allows replacing a damaged cable without sacrificing the sensor. Installation and adjustment are facilitated by an external $\frac{1}{2}$ -20 mounting thread and the two locknuts supplied with each unit.

Like in most of our LVDTs, the GCD windings are vacuum impregnated with a specially formulated, high temperature, flexible resin, and the coil assembly is potted inside its housing with a two-component epoxy. This provides excellent protection against hostile environments such as high vibration and shock.

The ruggedness, long life cycle, and very high reliability of the GCD Series provide a low cost of ownership over the life of the equipment onto which they are installed. The one-piece front end (barrel which contains the bearing assembly), machined from solid stainless steel bar, coupled with a bronze bushing, has far greater resistance to bending forces and side loads compared to other designs. This is particularly important on the longer stroke versions; it reduces the common risk of probe damage/bending during installation or maintenance of industrial equipment. The GCD Series designs also require fewer parts and weld joints, thereby increasing overall structural integrity and reliability.

MEAS offers options, such as mating connector plugs, special contact tips (including AGD dial indicator tips), air-extend/spring retract, and cable assemblies. Also see our other models with built-in signal conditioning, **GCD-SE** (single-ended DC voltage), **GCT** (4-20mA 2-wire loop) and **GC-485** (RS-485 Digital Series), as well as the AC operated **GCA**.

Measurement Specialties, Inc. (NASDAQ MEAS) offers many other types of sensors and signal conditioners. Data sheets can be downloaded from our web site at: <http://www.meas-spec.com/datasheets.aspx>

MEAS acquired Schaevitz Sensors and the **Schaevitz™** trademark in 2000.

FEATURES

- All-welded stainless steel construction
- Resistant to harsh environments
- MS type connector (MIL-C-5015)
- Long cycle life
- CE compliant
- Calibration certificate supplied with each unit
- Air extend/spring retract available (*Consult factory*)

APPLICATIONS

- Factory automation
- Industrial printing equipment
- Steel mills
- Metal thickness gaging
- Environments requiring hermetically sealed transducers
- In-process measurements (feedback loop with PLC or CNC controller)

GCD Series – DC Operated Gage Heads

PERFORMANCE SPECIFICATIONS

ELECTRICAL SPECIFICATIONS						
Parameter	GCD-050	GCD-125	GCD-250	GCD-500	GCD-1000	GCD-2000
Stroke/gaging range	±0.050 [1.27]	±0.125 [3.17]	±0.25 [6.35]	±0.50 [12.7]	±1.0 [25.4]	±2.0 [50.8]
Sensitivity, volts/inch	200	80	40	20	10	5
Input voltage	+/-15VDC					
Input current	30mA, maximum					
Output at stroke ends	+/-10VDC (Output is positive when the core is displaced from null towards the connector)					
Non-linearity	±0.25% of FR, maximum					
Repeatability	25 µ-inch [0.6 µm]					
Stability	0.125% of FSO after warm up					
Frequency response (dynamic)	15Hz, maximum					

ENVIRONMENTAL SPECIFICATIONS & MATERIALS	
Operating temperature	+32°F to +160°F [0°C to 70°C]
Survival temperature	-65°F to +200°F [-55°C to 95°C]
Shock survival	250 g (11ms half-sine)
Vibration tolerance	10 g up to 2kHz
Housing material	AISI 400 Series stainless steel
Electrical connector	6-pin MS type connector (MIL-C-5015)
IEC 60529 rating	IP68 to 1,000 PSI [70 bars] with use of proper mating connector plug

Notes:

All values are nominal unless otherwise noted

Dimensions are in inch [mm] unless otherwise noted

FR: Full Range is the stroke range, end to end; FR=2xS for ±S stroke range

FSO (Full Scale Output): Largest absolute value of the outputs measured at the ends of the range

WIRING INFORMATION

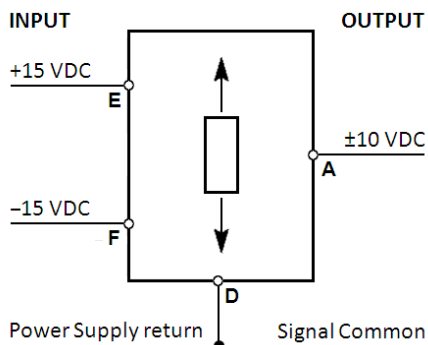

A through F: Connector pin assignments

GCD Series – DC Operated Gage Heads

MECHANICAL SPECIFICATIONS

Parameter	GCD-050	GCD-125	GCD-250	GCD-500	GCD-1000	GCD-2000
Stroke/gaging range	±0.050 [1.27]	±0.125 [3.17]	±0.25 [6.35]	±0.5 [12.7]	±1 [25.4]	±2 [50.8]
Pre-travel	0.20 [5.1]	0.23 [5.8]	0.05 [1.3]	0.20 [5.1]	0.14 [3.6]	0.10 [2.5]
Over-travel (minimum)	0.39 [9.90]	0.25 [6.4]	0.20 [5.1]	1.0 [25.4]	0.15 [3.81]	0.00 [0.0]
Main body length "A"	2.66 [67.6]	3.5 [88.9]	4.37 [111.0]	6.06 [153.9]	8.31 [211.1]	11.63 [295.4]
Overall body length "B"	4.02 [102.1]	4.87 [123.7]	5.74 [145.8]	9.05 [229.9]	11.29 [286.8]	17.12 [434.8]
Plunger length "C" (fully extended)	5.08 [129.0]	5.90 [149.9]	6.77 [172.0]	11.53 [292.9]	13.76 [349.5]	21.67 [550.4]
Weight, Ounce	2.5 oz	3.3oz	3.5 oz	5.5 oz	8.0 oz	14.0 oz
Weight, Gram	71 G	93 G	100 G	156 G	227 G	397 G
Spring force	Typically 9oz [255 grams] at fully compressed electrical stroke					

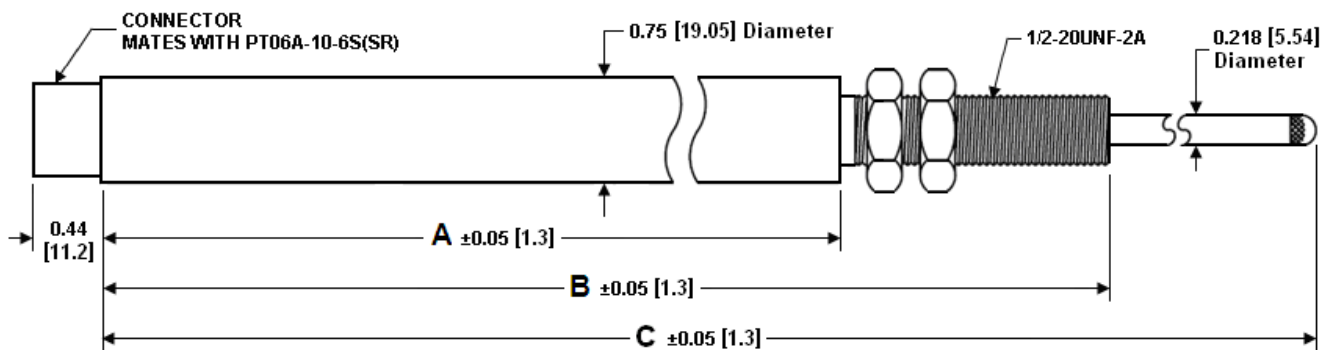

REPLACEMENT/OPTIONAL CONTACT TIPS

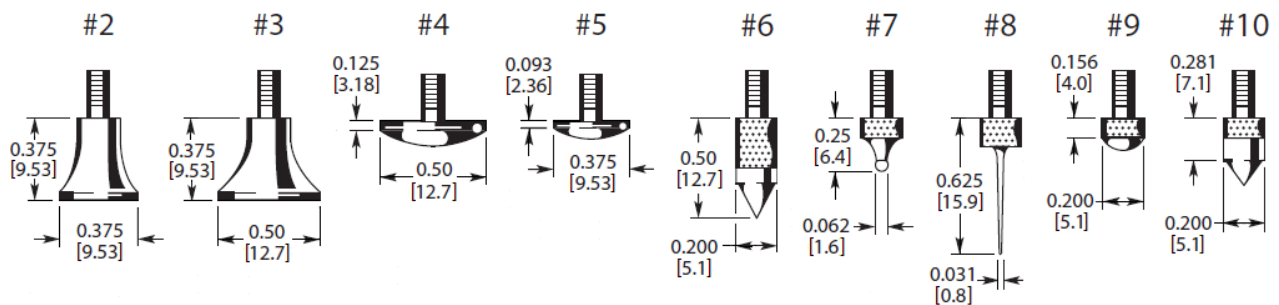

Dimensions are in inch [mm]