

HCD SERIES

Hermetically Sealed DC LVDT

SPECIFICATIONS

- ◆ Hermetically sealed, all welded
- ◆ Stainless steel housing
- ◆ High level ± 10 VDC output
- ◆ Stroke ranges from ± 0.05 to ± 10 inches
- ◆ Shock and vibration tolerant
- ◆ MS style connector
- ◆ IEC IP68 rating to 1,000 PSI [70 bars]
- ◆ Captive core option

The **HCD Series** hermetically sealed DC operated LVDTs are the perfect choice for high performance measurements in environments containing moisture, dirt, and fluid contaminants. Operating on a nominal ± 15 VDC supply, these heavy-duty LVDTs deliver an extremely linear, low noise, yet high frequency response ± 10 VDC output.

The integral electrical connector (welded, glass-sealed MS type) provides for easy installation and allows replacing a damaged cable without sacrificing the sensor.

The HCD is available in stroke ranges of ± 0.05 inch [± 1.27 mm] up to ± 10 inches [± 254 mm], and with a number of standard options including imperial or metric threaded core, guided core and captive core.

Like in most of our LVDTs, the HCD windings are vacuum impregnated with a specially formulated, high temperature, flexible resin, and the coil assembly is potted inside its housing with a two-component epoxy. This provides excellent protection against hostile environments such as high vibration and shock.

Captive core option: The HCD features an optional captive core design (available for most models) that greatly simplifies installation. The core rod and bearing assembly includes a Bronze bearing on the front end for self-alignment, while a PTFE sleeve allows low-friction travel through the stainless steel boreliner (spool tube).

FEATURES

- ◆ All-welded stainless steel construction
- ◆ Shock and vibration tolerant
- ◆ Low noise, ± 10 VDC output
- ◆ Double magnetic shielding
- ◆ MS type connector (MIL-C-5015)
- ◆ Calibration certificate supplied with each unit

APPLICATIONS

- ◆ Harsh industrial environments
- ◆ Pressurized installations up to 1,000 psi
- ◆ Paper processing mills
- ◆ Roller gap position feedback
- ◆ Automated test systems
- ◆ X-Y Positional Feedback

HCD SERIES

Hermetically Sealed DC LVDT

PERFORMANCE SPECIFICATIONS

ELECTRICAL SPECIFICATIONS									
Parameter	HCD 050	HCD 125	HCD 250	HCD 500	HCD 1000	HCD 2000	HCD 3000	HCD 5000	HCD 10000
Stroke range	±0.050 [±1.27]	±0.125 [±3.17]	±0.25 [±6.85]	±0.5 [±12.7]	±1 [±25.4]	±2 [±50.8]	±3 [±76.2]	±5 [±127]	±10 [±254]
Sensitivity, VDC/inch	200	80	40	20	10	5	3.3	2.0	1.0
Sensitivity, VDC/mm	7.87	3.15	1.575	0.787	0.394	0.197	0.130	0.079	0.0394
Frequency response Hertz @ -3db	500	500	500	200	200	200	200	200	200
Input voltage	+/-15VDC								
Input current	±25mA								
Output @ stroke ends	+/-10VDC (Output is positive when the core is displaced from null towards the connector)								
Non-linearity	±0.25% of FR, maximum								
Output ripple	25mVRMS, maximum								
Stability	0.125% of FSO								
Output impedance	1 Ohm								

ENVIRONMENTAL SPECIFICATIONS & MATERIALS	
Operating temperature	+32°F to +160°F [0°C to +70°C]
Survival temperature	-65°F to +200°F [-55°C to +95°C]
Shock survival	250 g (11 ms half-sine)
Vibration tolerance	10 g up to 2kHz
Housing material	AISI 400 Series stainless steel
Electrical connector	6-pin MS type connector (MIL-C-5015)
IEC 60529 rating	IP68 to 1,000 PSI [70 bars] with use of proper mating connector plug

Notes:

All values are nominal unless otherwise noted

Dimensions are in inch [mm] unless otherwise noted

FR: Full Range is the stroke range, end to end; FR=2xS for ±S stroke range

FSO (Full Scale Output): Largest absolute value of the outputs measured at the ends of the range

WIRING INFORMATION

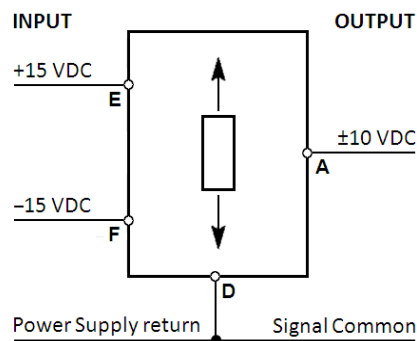

A through F: Connector pin assignments

HCD SERIES

Hermetically Sealed DC LVDT

MECHANICAL SPECIFICATIONS – NON CAPTIVE CORE (STANDARD)

Parameter	HCD 050	HCD 125	HCD 250	HCD 500	HCD 1000	HCD 2000	HCD 3000	HCD 5000	HCD 10000
Main body length "A"	2.40 [61.0]	3.23 [82.0]	4.10 [104.1]	5.79 [147.1]	8.05 [204.5]	11.42 [290.1]	16.62 [422.1]	20.45 [519.4]	34.57 [878.1]
Core length "B"	0.75 [19.1]	1.25 [31.8]	2.0 [50.8]	3.0 [76.2]	3.8 [96.5]	5.3 [134.6]	6.2 [157.5]	6.2 [157.5]	12.0 [304.8]
Bore depth "C"	1.90 [48.3]	2.73 [69.3]	3.60 [91.4]	5.29 [134.4]	7.55 [191.8]	10.92 [277.4]	16.10 [408.9]	19.95 [506.7]	34.03 [864.4]
Core center @null "P"	0.55 [14.0]	0.96 [24.4]	1.39 [35.3]	2.23 [56.6]	3.18 [80.8]	4.91 [124.7]	7.59 [192.8]	9.56 [242.8]	16.61 [421.9]
Weight, body oz [gram]	1.41 [40]	1.77 [50]	2.19 [62]	2.93 [83]	4.24 [120]	6.14 [174]	8.33 [236]	10.38 [294]	18.57 [526]
Weight, core oz [gram]	0.07 [2]	0.11 [3]	0.18 [5]	0.28 [8]	0.35 [10]	0.53 [15]	0.64 [18]	0.64 [18]	0.85 [24]

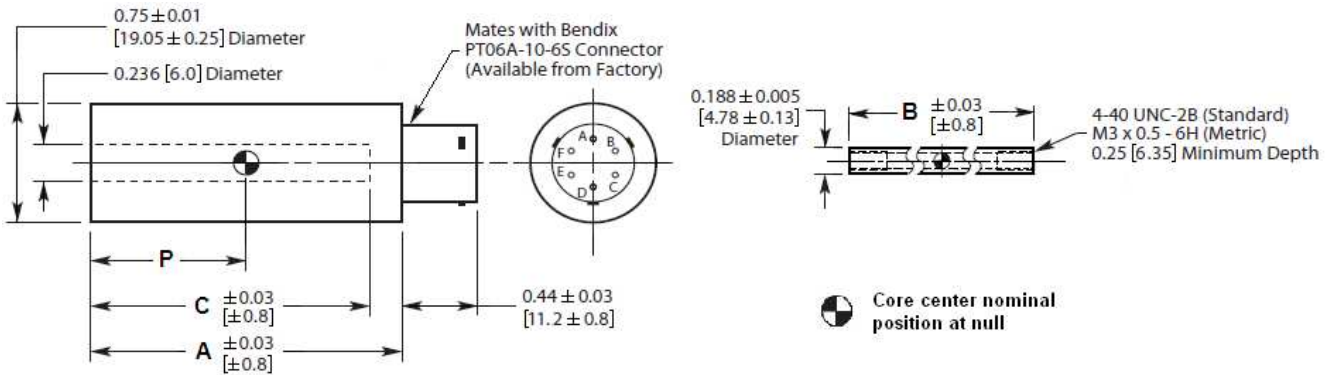

MECHANICAL SPECIFICATIONS – CAPTIVE CORE OPTION

Parameter	HCD 050	HCD 125	HCD 250	HCD 500	HCD 1000	HCD 2000	HCD 3000
Main body length "A"	2.74 [69.6]	3.57 [90.7]	4.44 [112.8]	6.13 [155.7]	8.39 [213.1]	11.76 [298.7]	16.96 [430.8]
Core center at null "P"	0.89 [22.6]	1.30 [33.0]	1.73 [43.9]	2.57 [65.3]	3.52 [89.4]	5.25 [133.4]	7.93 [201.4]
Core rod position at null "R"	3.78 [96.0]	4.36 [110.7]	4.85 [123.2]	6.04 [153.4]	7.90 [200.7]	10.52 [267.2]	15.27 [387.9]
Weight, oz [gram]	2.19 [62]	2.65 [75]	3.14 [89]	4.06 [115]	5.61 [159]	7.87 [223]	10.63 [301]

