

DC-EC Series – General purpose DC LVDT



- High level ± 10 VDC output
- Stroke ranges from ± 0.05 to ± 10 in
- 0.25% linearity
- Reverse polarity protection
- Double magnetic shielding
- Stainless steel housing
- Imperial or metric threaded core

DESCRIPTION

The **DC-EC Series** DC operated LVDTs combine a computer-designed AC LVDT with custom integral signal conditioning to achieve premium performance. Operating on a nominal ± 15 VDC supply, the DC-EC Series delivers an extremely linear, low noise, yet high frequency response ± 10 VDC output.

Innovative design and manufacturing techniques further enhance the DC-EC performance and cost efficiency. The micro-miniature components employed were meticulously selected for maximum stability and thermal performance. Vacuum encapsulation of all elements affords excellent shock and vibration tolerance, while double magnetic shielding provides the utmost protection from stray fields.

Like in most of our LVDTs, the DC-EC windings are vacuum impregnated with a specially formulated, high temperature, flexible resin, and the coil assembly is potted inside its housing with a two-component epoxy. This provides excellent protection against hostile environments such as high humidity, vibration and shock.

Available in a variety of stroke ranges from ± 0.05 to ± 10 inches, the DC-EC Series can be configured with a number of standard options including metric threaded core, guided core and small diameter/low mass core.

Captive core option: The DC-EC features an optional captive core design (available for most models) that greatly simplifies installation. The core rod and bearing assembly includes a Bronze bearing on the front end for self-alignment, while a PTFE sleeve allows low-friction travel through the stainless steel boreliner (spool tube). The core rod and the bearing assembly are both field serviceable.

Also see our other LVDTs with built-in signal conditioning: **DC-SE** (single-ended DC voltage), **HCD** (Hermetically sealed, \pm DC voltage), **HC-485** (RS485 digital output), and the **HCT** (4-20mA, 2-wire loop).

Measurement Specialties, Inc. (NASDAQ MEAS) offers many other types of sensors and signal conditioners. Data sheets can be downloaded from our web site at: <http://www.meas-spec.com/datasheets.aspx>

MEAS acquired Schaevitz Sensors and the **Schaevitz™** trademark in 2000.

FEATURES

- Bi-polar DC operation
- Shock and vibration tolerant
- Captive core option (*available on select models*)
- AISI 400 Series stainless steel housing
- CE compliant
- Calibration certificate supplied with each unit

APPLICATIONS

- Materials testing
- Z-axis position feedback for punch-presses
- Microscope X-Y stage position control
- Medical imaging
- Automotive suspension testing
- Flight simulators

DC-EC Series – General purpose DC LVDT

PERFORMANCE SPECIFICATIONS

ELECTRICAL SPECIFICATIONS									
Parameter	DC-EC 050	DC-EC 125	DC-EC 250	DC-EC 500	DC-EC 1000	DC-EC 2000	DC-EC 3000	DC-EC 5000	DC-EC 10000
Stroke range	±0.050 [±1.27]	±0.125 [±3.17]	±0.25 [±6.35]	±0.5 [±12.7]	±1 [±25.4]	±2 [±50.8]	±3 [±76.2]	±5 [±127]	±10 [±254]
Sensitivity, VDC/inch	200	80	40	20	10	5	3.3	2.0	1.0
Sensitivity, VDC/mm	7.9	3.15	1.6	0.79	0.39	0.20	0.13	0.079	0.039
Frequency response Hertz @ -3dB	500	500	500	200	200	200	200	200	200
Input voltage	±15VDC								
Input current	±25mA								
Output at stroke ends	±10VDC (Positive and increasing when the core is displaced from null position towards the cable)								
Non-linearity	±0.25% of FR, maximum								
Output ripple	25mVRMS, maximum								
Stability	0.125% of FSO								
Output impedance	1 Ohm								

ENVIRONMENTAL SPECIFICATIONS & MATERIALS	
Operating temperature	+32°F to +160°F [0°C to 70°C]
Survival temperature	-65°F to +200°F [-55°C to 95°C]
Shock survival	250 g (11ms half-sine)
Vibration tolerance	10 g up to 2kHz
Housing material	AISI 400 Series stainless steel
Electrical connection	Cable with 4 conductors, 28AWG stranded copper, braided shield and polyurethane jacket, 39 inches [1 meter] long. Shield is connected to case.
IEC 60529 rating	IP61

Notes:

All values are nominal unless otherwise noted

Dimensions are in inch [mm] unless otherwise noted

FR: Full Range is the stroke range, end to end; FR=2xS for ±S stroke range

FSO (Full Scale Output): Largest absolute value of the outputs measured at the ends of the range

WIRING INFORMATION

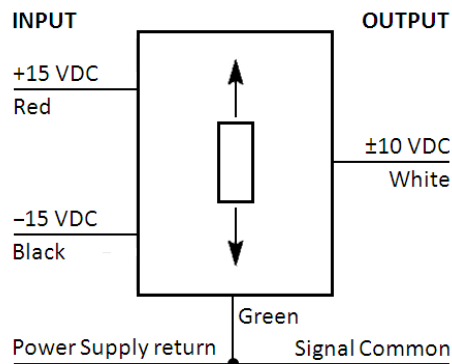

DC-EC Series – General purpose DC LVDT

MECHANICAL SPECIFICATIONS – NON-CAPTIVE CORE (STANDARD)

Parameter	DC-EC 050	DC-EC 125	DC-EC 250	DC-EC 500	DC-EC 1000	DC-EC 2000	DC-EC 3000	DC-EC 5000	DC-EC 10000
Main body length "A"	2.10 [53.3]	2.93 [74.4]	3.80 [96.5]	5.49 [139.4]	7.75 [196.9]	11.12 [282.4]	16.32 [414.5]	20.15 [511.8]	35.38 [898.7]
Core length "B"	0.75 [19.1]	1.25 [31.8]	2.00 [50.8]	3.00 [76.2]	3.80 [96.5]	5.30 [134.6]	6.20 [157.5]	6.20 [157.5]	12.00 [304.8]
Core center at null "P"	0.50 [12.7]	0.93 [23.6]	1.35 [34.3]	2.20 [55.9]	3.18 [80.8]	5.3 [134.6]	7.55 [191.8]	9.53 [242.1]	16.58 [421.1]
Body weight oz [gram]	2.19 [62]	2.44 [69]	2.58 [73]	2.93 [83]	4.24 [120]	5.47 [155]	9.39 [266]	11.47 [325]	15.71 [445]
Core weight oz [gram]	0.07 [2]	0.11 [3]	0.18 [5]	0.28 [8]	0.35 [10]	0.46 [13]	0.49 [14]	0.60 [17]	0.85 [24]

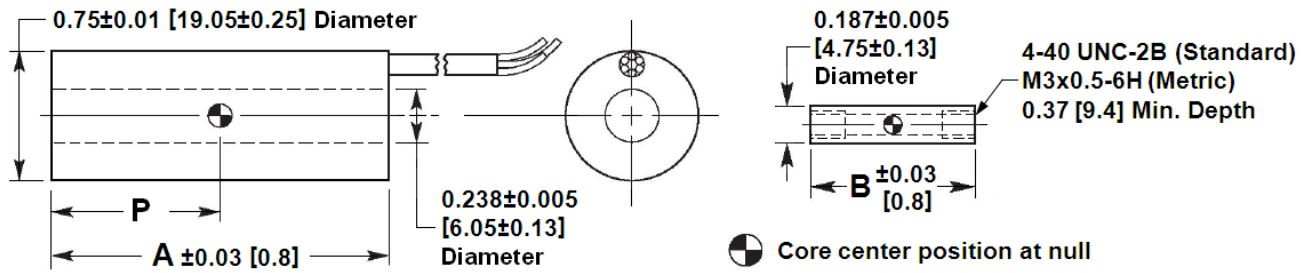

Dimensions are in inch [mm]

MECHANICAL SPECIFICATIONS – CAPTIVE CORE OPTION

Parameter	DC-EC 050	DC-EC 125	DC-EC 250	DC-EC 500	DC-EC 1000	DC-EC 2000	DC-EC 3000
Main body length "A"	2.48 [63.0]	3.31 [84.1]	4.18 [106.7]	5.87 [149.1]	8.13 [206.5]	11.50 [292.1]	16.70 [424.2]
Core rod position at null "R"	3.78 [96.0]	4.36 [110.7]	4.85 [123.2]	6.04 [153.4]	7.90 [200.7]	10.52 [267.2]	15.27 [387.9]
Center of core position at null "P"	0.84 [21.3]	1.27 [32.3]	1.69 [42.9]	2.54 [64.5]	3.52 [89.4]	5.22 [132.6]	7.89 [200.4]
Weight oz [gram]	2.97 [84]	3.32 [94]	3.53 [100]	4.02 [114]	5.61 [159]	7.2 [204]	11.68 [331]

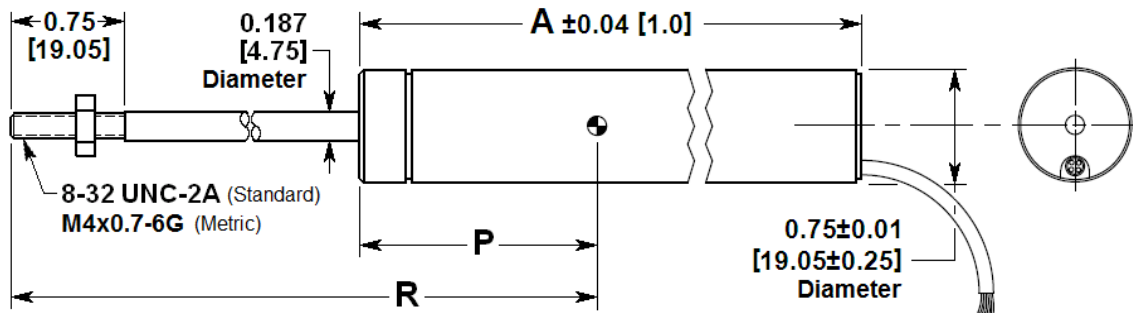

Dimensions are in inch [mm]