

**SURFACE MOUNT SCHOTTKY BARRIER RECTIFIER**

**VOLTAGE RANGE 20 to 40 Volts CURRENT 0.2 Ampere**

**FEATURES**

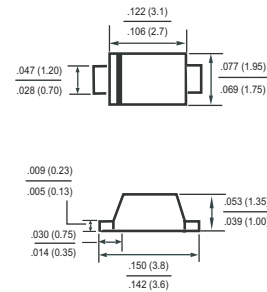
- \* Low power loss, high efficiency
- \* Low leakage
- \* Low forward voltage
- \* High current capability
- \* High speed switching
- \* High surge capability
- \* High reliability

**MECHANICAL DATA**

- \* Epoxy: Device has UL flammability classification 94V-0
- \* Mounting position: Any



**SOD-123F**



Dimensions in inches and (millimeters)

**MAXIMUM RATINGS AND ELECTRICAL CHARACTERISTICS**

Ratings at 25 °C ambient temperature unless otherwise specified.  
Single phase, half wave, 60 Hz, resistive or inductive load.  
For capacitive load, derate current by 20%.

**MAXIMUM RATINGS (@ TA=25 °C unless otherwise noted)**

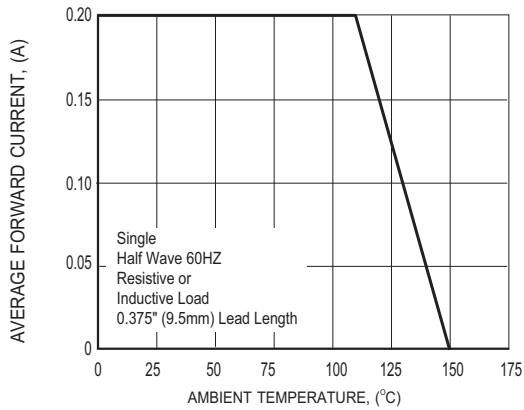
RATINGS	SYMBOL	02SSL20	02SSL30	02SSL40	UNITS
Maximum Recurrent Peak Reverse Voltage	VRRM	20	30	40	Volts
Maximum RMS Voltage	VRMS	14	21	28	Volts
Maximum DC Blocking Voltage	VDC	20	40	40	Volts
Maximum Average Forward Rectified Current .375" (9.5mm) lead length at TA=110°C	IO	0.2			Amps
Peak Forward Surge Current 8.3 ms single half sine-wave superimposed on rated load (JEDEC method)	IFSM	60			Amps
Typical Current Squared Time	I <sup>2</sup> t	14.9			A <sup>2</sup> S
Typical Junction Capacitance (Note1)	CJ	110			pF
Typical Thermal Resistance (Note 3)	ReJA	110			°C/W
	ReJL	30			
Operating Temperature Range	TJ	-55 to + 150			°C
Storage Temperature Range	TSTG	-55 to + 150			°C

**ELECTRICAL CHARACTERISTICS (@TA=25 °C unless otherwise noted)**

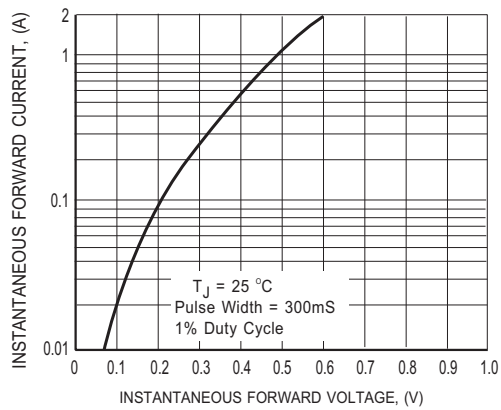
CHARACTERISTICS	SYMBOL	02SSL20	02SSL30	02SSL40	UNITS
Maximum Instantaneous Forward Voltage at 0.2A DC	VF	.28			Volts
Maximum Average Reverse Current at Rated DC Blocking Voltage	IR	@TA = 25°C			mAmps
		@TA = 150°C			mAmps

- NOTES : 1. Measured at 1 MHz and applied reverse voltage of 4.0 volts.  
2. " ROHS compliant"  
3. Thermal resistance: Mounted on PCB.

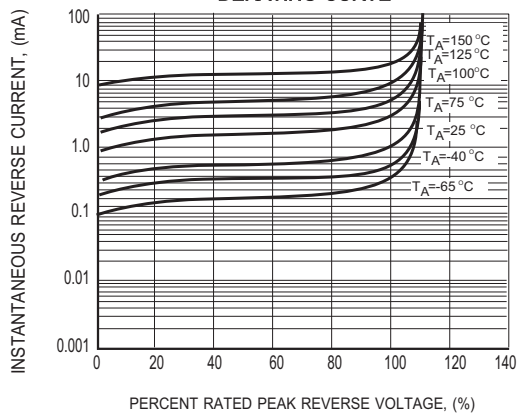
# RATING AND CHARACTERISTICS CURVES ( 02SSL20 THRU 02SSL40 )



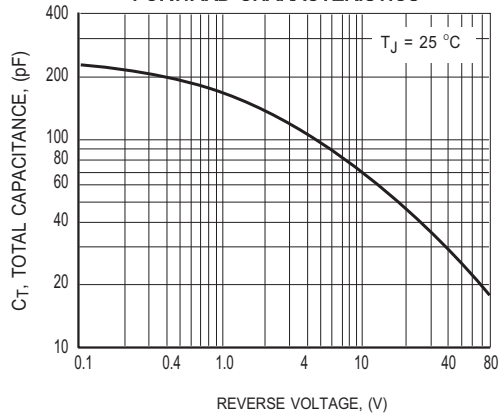
**FIG.1 TYPICAL FORWARD CURRENT DERATING CURVE**



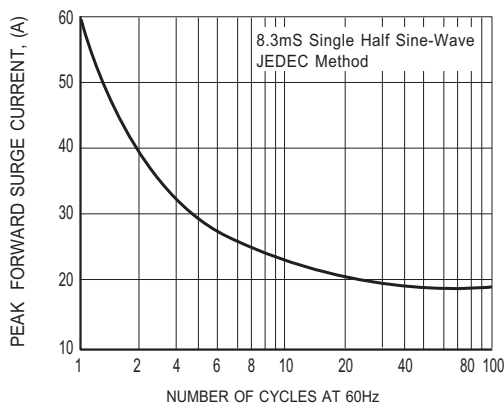
**FIG.2 MAXIMUM INSTANTANEOUS FORWARD CHARACTERISTICS**



**FIG.3 MAXIMUM REVERSE CHARACTERISTICS**

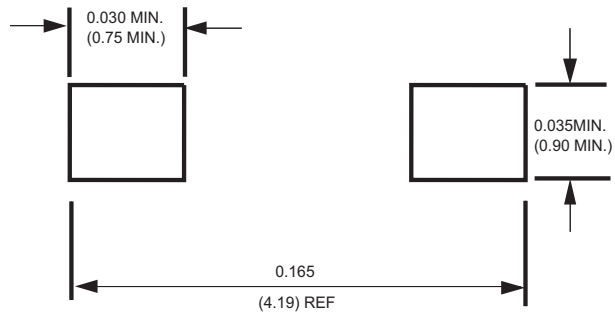


**FIG.4 TYPICAL JUNCTION CAPACITANCE**



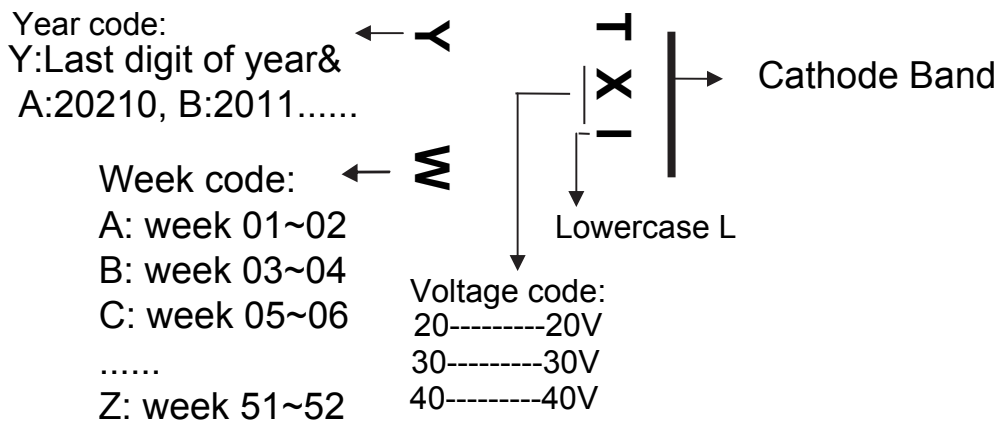
**FIG.5 MAXIMUM NON-REPETITIVE FORWARD SURGE CURRENT**

## Mounting Pad Layout



Dimensions in inches and (millimeters)

## Marking Description



## PACKAGING OF DIODE AND BRIDGE RECTIFIERS

### REEL PACK

PACKAGE	PACKING CODE	EA PER REEL	EA PER INNER BOX	COMPONENT SPACE (mm)	TAPE SPACE (mm)	REEL DIA (mm)	CARTON SIZE (mm)	EA PER CARTON	GROSS WEIGHT(Kg)
SOD-123F/ SOD-123FL	-W	3,000	15,000	---	---	178	390*205*31	120,000	6.964