

NOTES:

1. MATERIALS OF CONSTRUCTION:  
 LOCKWASHER & HEX NUT - BRASS, NICKEL PLATED  
 BODY - BRASS, GOLD PLATED OVER HIGH PHOSPHORUS CONTENT ELECTROLESS NICKEL  
 CONTACT - BeCu, GOLD PLATED OVER HIGH PHOSPHORUS CONTENT ELECTROLESS NICKEL  
 RETAINING RING & CAP - BRASS, NICKEL PLATED  
 INSULATORS - PTFE  
 GASKETS - SILICONE RUBBER
2. ELECTRICAL:  
 A. IMPEDANCE: 50 OHM  
 B. FREQUENCY RANGE: DC - 3 GHz  
 C. VSWR: 1.29 MAX TO 3.0 GHz
3. MECHANICAL:  
 A. TEMPERATURE RANGE: -65° C TO +165° C  
 B. SEALING REQUIREMENTS: DESIGN WHEN MOUNTED ON PANEL MUST WITHSTAND WATER PRESSURE AT DEPTH OF 1 METER FOR 30 MIN. WITHOUT ANY SIGN OF LEAKAGE
4. PACKAGING:  
 A. QUANTITY: TRAY PACK, 25 PCS/TRAY  
 B. MARKING: TRAY TO BE MARKED "AMPHENOL, 31-6528, AND DATE CODE"

THIRD ANGLE PROJ.

REVISIONS

REV	DESCRIPTION	DATE	ECO	APPR
A	RELEASE TO MFG.	29-Mar-12	48962	DD
B	ADD ARC LOGO TO BODY	10-Oct-13	49619	RLB
C	UPDATED NOTE 4.A	28-Aug-18	08965	SH

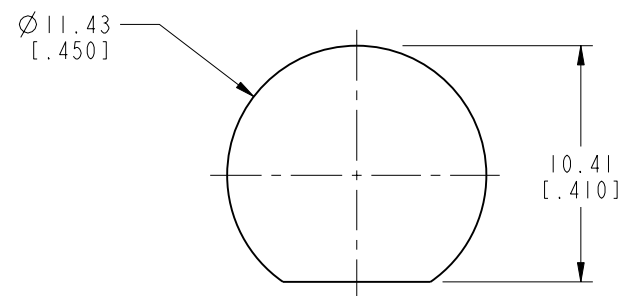

**RECOMMENDED MOUNTING PANEL DIMENSIONS**

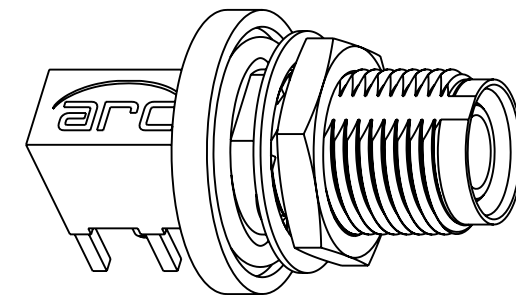

SCALE 2.000

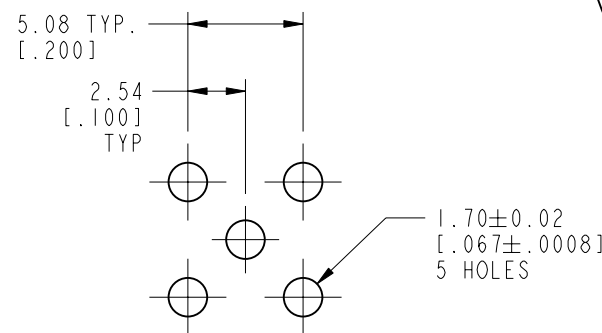
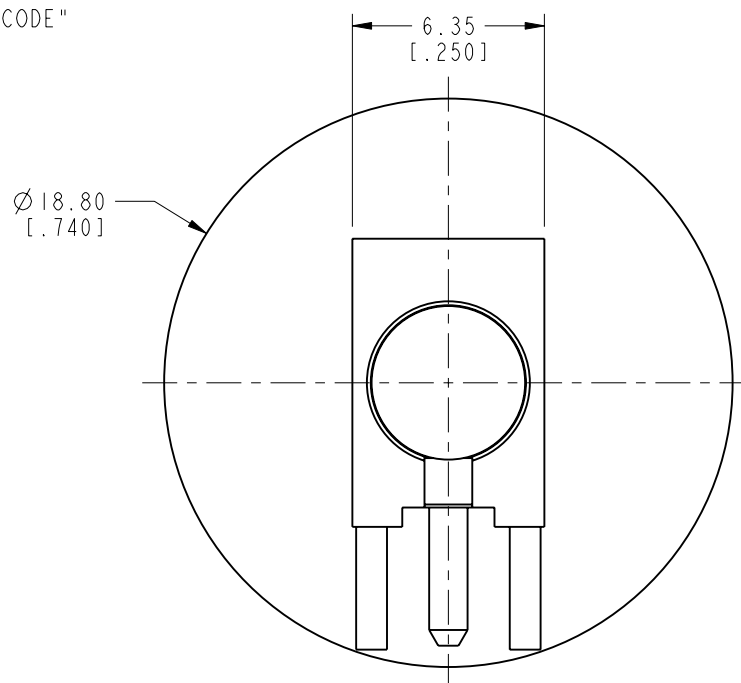

**RECOMMENDED MOUNTING HOLE DIMENSIONS**  
SCALE 3.000

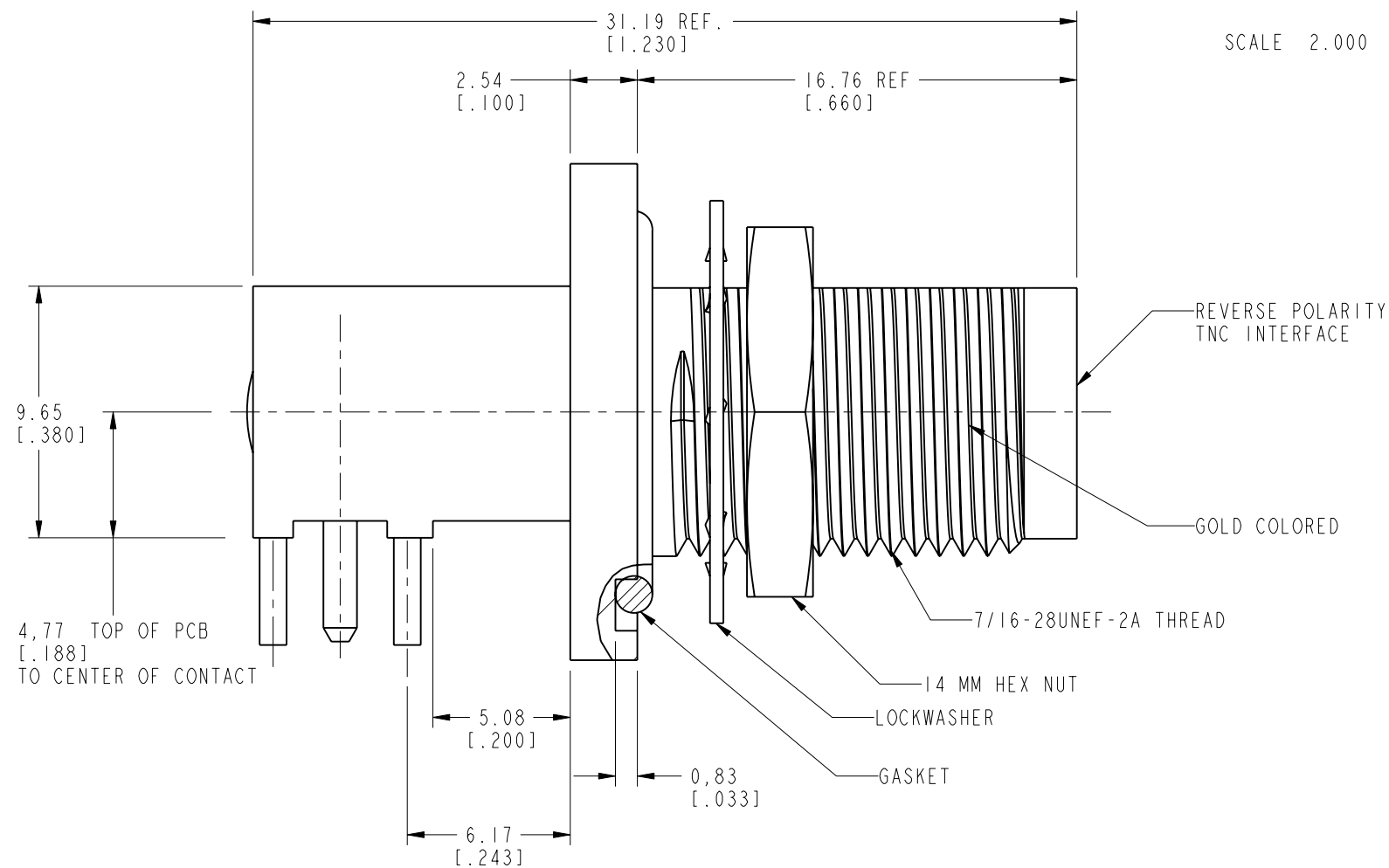

**CUSTOMER OUTLINE DRAWING**

ALL OTHER SHEETS ARE FOR INTERNAL USE ONLY

UNLESS OTHERWISE SPECIFIED, DIMENSIONS ARE IN METRIC AND TOLERANCES ARE: <0.5mm ±0.05mm    0.5 - 6mm ±0.1mm    6 - 30mm ±0.2mm    30 - 120mm ±0.3mm    ANGLES ±1°	MATERIAL	DRAWN	DATE	TITLE RP TNC JACK (IP67) R/A BULKHEAD PCB MOUNT		Amphenol RF www.amphenolrf.com	
	SEE NOTES	M. ZHANG	28-Aug-18				
NOTICE - These drawings, specifications, or other data (1) are, and remain the property of Amphenol corp. (2) must be returned upon request; and (3) are confidential and not to be disclosed to any person other than those to whom they are given by Amphenol Corp. the furnishing of these drawings, specifications, or other data by Amphenol Corp., or to any other person for any purpose is not to be regarded by implication or otherwise in any manner licensing, granting rights to permitting such holder or any other person to manufacture, use or sell any product, process or design, patented or otherwise, that may in any way be related to or disclosed by said drawings, specifications, or other data.	REFERENCE	ENGINEER	DATE	SCALE: 6.0:1.0    SHEET 2 OF 2		DRAWING NO. 31-6528 ITEM NO. 31-6528	
	EAR # 4007	D. DAVE	30-Jan-12				
	CONFIGURATION LEVEL: In Work	APPROVED	DATE		DWG SIZE    REV B                    C		PART NO. 31-6528
FINISH	S. HSIEH	28-Aug-18	CAD FILE				