

CLASS 1

These drawings and specifications are the property of Microdot Inc., are issued in strict confidence and shall not be divulged, be reproduced or copied, or used as the basis for the manufacture or sale of any article without written permission of Microdot Inc.

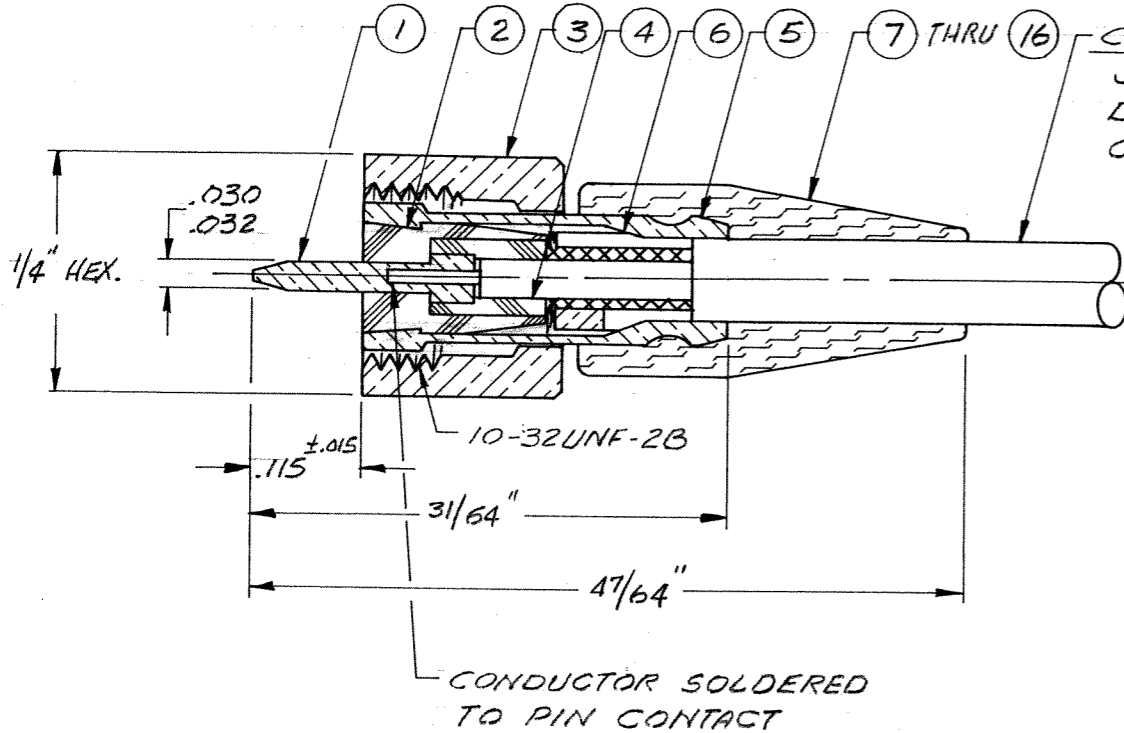

4-1532004-1

9	8	7	6	5	4	3	2	1	0	PART NO.	NOMENCLATURE	MAT'L & SPEC	FINISH	ITEM
										003-0270-0009	B.R. CAP (WHITE)	SILICONE RUBBER, ZZ-R-765		16
										003-0270-0008	B.R. CAP (GREY)			15
										003-0270-0007	B.R. CAP (VIOLET)			14
										003-0270-0006	B.R. CAP (BLUE)			13
										003-0270-0005	B.R. CAP (GREEN)			12
										003-0270-0004	B.R. CAP (YELLOW)			11
										003-0270-0003	B.R. CAP (ORANGE)			10
										003-0270-0002	B.R. CAP (RED)			9
										003-0270-0001	B.R. CAP (BROWN)			8
										003-0270-0000	BR. CAP (BLACK)	SILICONE RUBBER, ZZ-R-765		7
										003-D163-0001	RING	BRASS - QQ-B-626	5	6
										003-0160-0001	FERRULE	BRASS - QQ-B-626	5	5
										003-0153-0001	BUSHING	TEFLON - MIL-M-14077		4
										003-0454-0001	NUT	BRASS - QQ-B-626	5	3
										003-0205-0001	BUSHING	TEFLON - MIL-M-14077		2
										003-0360-0002	PIN CONTACT	BRASS - QQ-B-626	4	1
ASTERISK (*) NUMBER														

- 6. 032-0098-00X1 SAME AS 032-0098-X
 - 5. SILVER PLATE .0002-.0004 PER QQ-S-365 TYPE II, GRADE A
 - 4. GOLD PLATE .00005 MIN. PER MIL-G-45204. TYPE II, CLASS I.
 - 3. 032-0098-0001 (BLACK B.R. CAP) WILL BE SUPPLIED UNLESS OTHERWISE SPECIFIED.
 - 2. FOR ASSEMBLY INSTRUCTIONS SEE BULLETIN #48. USE TOOL T-3221 OR 010-0003-0000
 - 1. THIS CONNECTOR MATES WITH ALL S-50 JACKS & RECEPT. AS LISTED IN MICRODOT CAT.
- NOTES: UNLESS OTHERWISE SPECIFIED

ASSEMBLY	NO REQ'D	LET	ECO	REVISION DESCRIPTION	BY	DATE	APP
				ITEMS 7 THRU 16 WAS 003-0031-0000 THRU 0009	B	3-21-55	JS
				REV. LETTER UP-DATED	J	3/27/56	JS
				COMPONENT NO UP-DATED	GK	4/12/56	JS
				UP-DATED PART NO. REVISED & REDRAWN	U.M.	3/18/67	JS

STANDARD TOLERANCES UNLESS OTHERWISE SPECIFIED
 DEC. ± .010
 FRAC. ± 1/32"
 ANGLES ±
 ECCENTRICITY
 MAX. T.I.R. _____
 HOLE DIA. ±
 SURFACE ROUGHNESS
 MICRO INCHES
 THREADS TO MIL-S-7742
 COMMERCIAL TOLERANCES APPLY TO STOCK DIMENSIONS

MICRODOT INC.
 SOUTH PASADENA, CALIF.

SURFACE TREATMENT NOTED

MATERIAL NOTED

APPROVED BY: J. WESS
 APP: 1/24/65
 CHECKED BY:
 DRAWN BY: M.F.M. (V.M.)
 SCALE: 5/1
 WT: _____
 DATE: 1-10/61
 DRAWING NUMBER: 032-0098-00X1 H
 CODE: 931
 CDM

PLUG