

General Specifications

Motor Type: DC Brushless Motor

Motor Protection:

Auto Restart/Polarity Protection
(Motor withstands reverse connection for positive and negative leads.)

Insulation Resistance:

10M Ω or over with a DC500V Megger

Dielectric Withstand Voltage:

AC 700V 1s or 500V 1min

Allowable Ambient Temperature Range:

-10°C ~ +70°C (Operating)
-40°C ~ +70°C (Storage)
(non-condensing environment)

Characteristics Curves

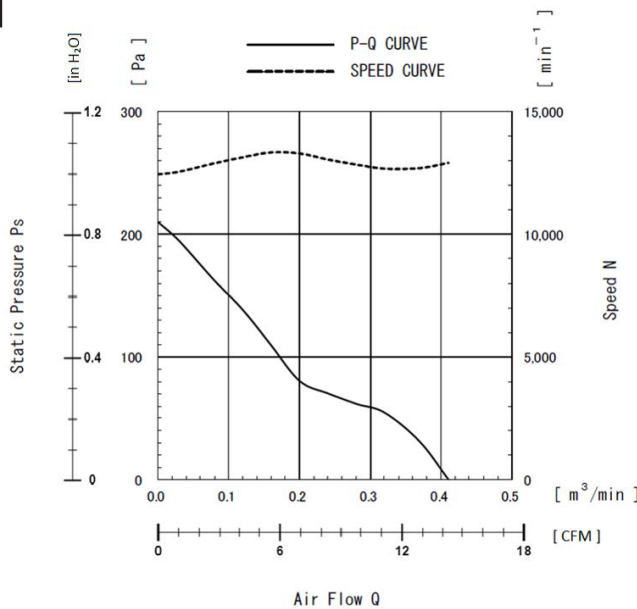

Specifications

MODEL	Rated Voltage	Operating Voltage	Current		Input Power		Speed	Max. Air Flow		Max. Static Pressure		Noise	Mass
	(V)	(V)	Avg	Max	Avg	Max		(CFM)	(m ³ /min)	(inH ₂ O)	(Pa)		
	(V)	(V)	(A) ^{*1}	(A) ^{*1}	(W) ^{*1}	(W) ^{*1}	(min ⁻¹) ^{*1}	(CFM)	(m ³ /min)	(inH ₂ O)	(Pa)	(dB) ^{*1}	(g)
04028VE-12N-CT-00	12	10.8 ~ 13.2	0.23	0.30	2.76	3.60	13,000	14.48	0.41	0.84	210	44.5	55

*1: Values in Free Air

IP Rated Fan Benefits & Applications

IP 68/69K

NMB offers the industry's highest Ingress Protection (IP) rated cooling fans. IP69K fans provide dust tight protection, and safeguard against powerful, high temperature, water jets for outdoor applications and other harsh environments. NMB fans are designed with NMB precision machined ball bearings with stainless steel outer ring and stainless steel or ceramic balls, assuring long life and high reliability.

Benefits

- IP69K rating per IEC 60529 standard
- Long life and high reliability with NMB precision ball bearings
- Open Collector Tacho Signal output for fan speed

Applications

- Outdoor Applications
- Factory Automation
- Food Processing
- Refrigeration
- LED Lighting
- Inverters
- Telecomm
- Horticulture

Life Expectancy L10

60°C 40,000 Hours

TACHO Specifications

TACHOMETER SIGNAL

1. OUTPUT CIRCUIT : OPEN COLLECTOR)
2. SPECIFICATION

Absolute Maximum Ratings at Ta=25°C

$V_{CE\ max}$: +15V

$I_c\ max$: 5mA [$V_{CE(sat)max}$ = 0.5V]

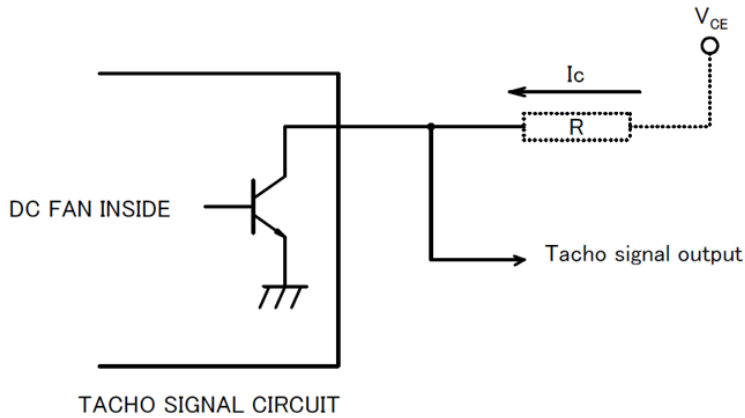

3. OUTPUT WAVEFORM: RATED VOLTAGE

OUTPUT SIGNAL VOLTAGE

3-1 Case-1

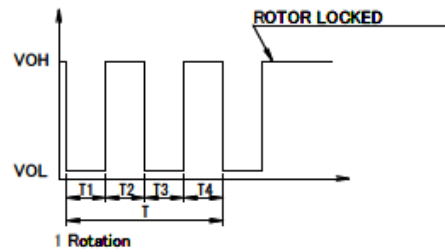

3-2 Case-2

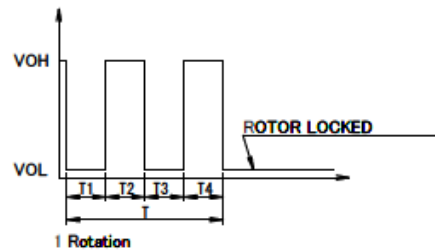

- 1) When the rotor is locked at VOH position of signal, signal keeps VOH position.
- 2) When the rotor is locked at VOL position of signal, signal keeps VOL position.
- 3) $T = T1 + T2 + T3 + T4 = 60/m$, $m=1$ rotation

m : min^{-1}

Tacho Duty Cycle = $50\% \pm 10\%$