

RPC-N
50 Ω

Open Circuit
Jack

05K12L-000S3

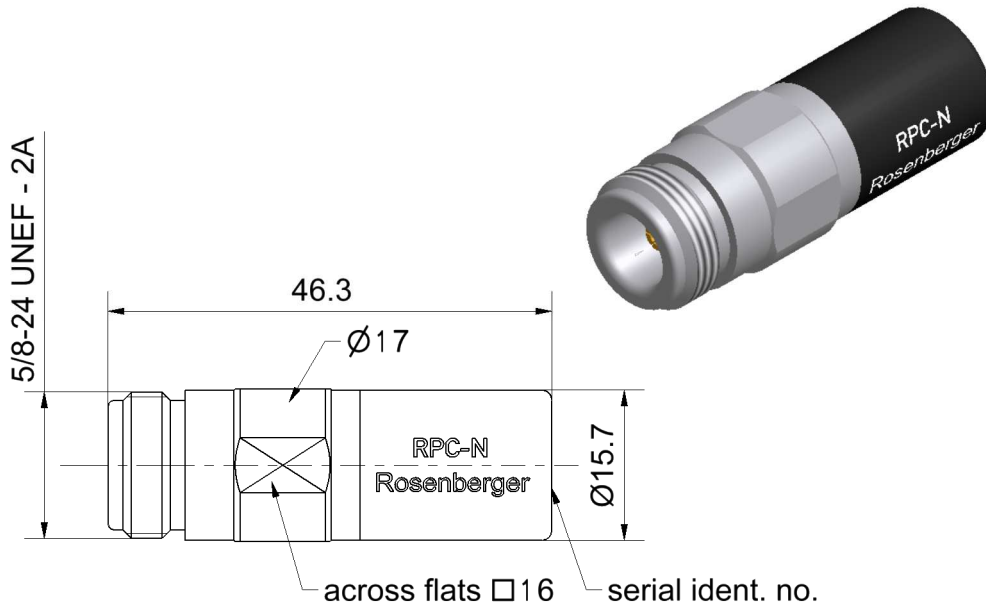

All dimensions are in mm; tolerances according to ISO 2768 m-H

Interface

According to IEC 61169-16

Documents

Application note AN001 "Calibration Services"

Material and plating

Connector parts
Center conductor
Outer conductor
Dielectric

Material
CuBe
Stainless steel
PS

Plating
Gold, min. 1.27 μm, over nickel
Passivated

Dieses Dokument ist urheberrechtlich geschützt • This document is protected by copyright • Rosenberger Hochfrequenztechnik GmbH & Co. KG

RF_35/09;14/6.2

Electrical data

Frequency range	DC to 18 GHz
Return loss	≤ 0.10 dB, DC to 4 GHz ≤ 0.15 dB, 4 GHz to 8 GHz ≤ 0.20 dB, 8 GHz to 18 GHz
Error from nominal phase ¹	≤ 1.5°, DC to 4 GHz ≤ 2.0°, 4 GHz to 8 GHz ≤ 3.0°, 8 GHz to 18 GHz

¹ The nominal phase is defined by the Offset Delay, the Offset Loss and the Fringing Capacitances.

Mechanical data

Mating cycles	≥ 500
Maximum torque	1.70 Nm
Recommended torque	1.10 Nm
Gauge	5.22 mm to 5.26 mm

General standard definitions

For proper operation the vector network analyzer (VNA) needs a model describing the electrical behaviour of this calibration standard. The different models, units, and terms used will depend on the VNA type and they will have to be entered into the VNA. All values are based on typical geometry and plating.

Offset Z_o / Impedance / Z_o	50 Ω
Offset Delay	50.3682 ps
Length (electrical) / Offset Length	15.10 mm
Offset Loss	0.80 GΩ/s
Loss	0.0070 dB/√GHz
Fringing Capacitances ²	

² Fringing Capacitances are determined individually for each open circuit and are documented in a Calibration Certificate.

Environmental data

Operating temperature range ³	+ 20 °C to +26 °C
Rated temperature range of use ⁴	0 °C to +50 °C
Storage temperature range	- 40 °C to +85 °C

RoHS compliant

³ Temperature range over which these specification are valid.

⁴ This range is underneath and above the operating temperature range, within the open circuit is fully functional and could be used without damage.