

RPC-N  
50 Ω

Offset Short  
Jack

**05K12S-002S3**

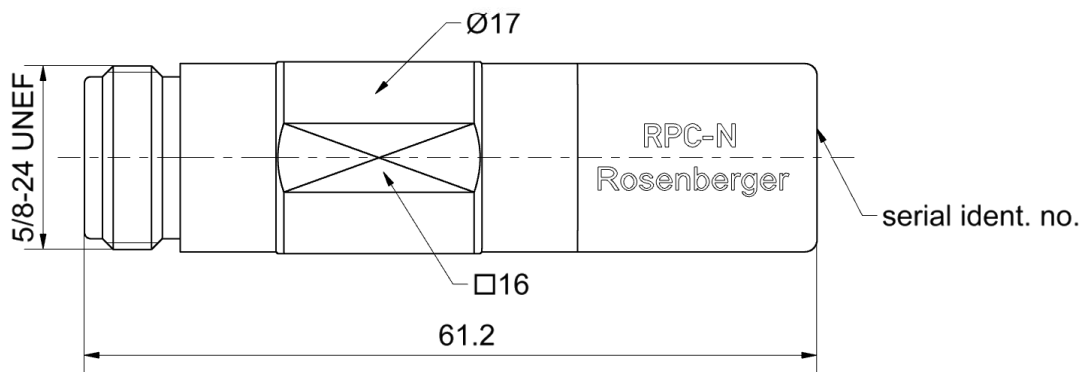

All dimensions are in mm; tolerances according to ISO 2768 m-H

**Interface**

According to IEC 61169-16

**Documents**

Application note AN001 "Calibration Services"

**Material and plating**

**Connector parts**

Center conductor  
Outer conductor

**Material**

CuBe  
Stainless steel

**Plating**

Gold, min. 1.27 μm, over nickel  
Passivated

Dieses Dokument ist urheberrechtlich geschützt • This document is protected by copyright • Rosenberger Hochfrequenztechnik GmbH & Co. KG

RF\_35/09;14/6.2

**Electrical data**

Frequency range	DC to 18 GHz
Return loss	≤ 0.10 dB, DC to 4 GHz ≤ 0.15 dB, 4 GHz to 8 GHz ≤ 0.20 dB, 8 GHz to 18 GHz
Error from nominal phase <sup>1</sup>	≤ 1.2°, DC to 4 GHz ≤ 1.5°, 4 GHz to 8 GHz ≤ 2.5°, 8 GHz to 18 GHz

<sup>1</sup> The nominal phase is defined by the Offset Delay, the Offset Loss and the Short Inductance.

**Mechanical data**

Mating cycles	≥ 500
Maximum torque	1.70 Nm
Recommended torque	1.10 Nm
Gauge	5.22 mm to 5.26 mm

**General standard definitions**

For proper operation the vector network analyzer (VNA) needs a model describing the electrical behaviour of this calibration standard. The different models, units, and terms used will depend on the VNA type and they will have to be entered into the VNA. All values are based on typical geometry and plating.

Offset $Z_o$ / Impedance / $Z_o$	50 Ω
Offset Delay	100.069 ps
Length (electrical) / Offset Length	30.00 mm
Offset Loss	0.80 GΩ/s
Loss	0.0139 dB/√GHz
Short Inductance <sup>2</sup>	

<sup>2</sup> Short Inductances are determined individually for each Short circuit and are documented in a Calibration Certificate.

**Environmental data**

Operating temperature range <sup>3</sup>	+20 °C to +26 °C
Rated temperature range of use <sup>4</sup>	0 °C to +50 °C
Storage temperature range	- 40 °C to +85 °C

RoHS compliant

<sup>3</sup> Temperature range over which these specification are valid.

<sup>4</sup> This range is underneath and above the operating temperature range, within the short circuit is fully functional and could be used without damage.