

RPC-N
50 Ω

Calibration Load
Jack

05K150-C10S3

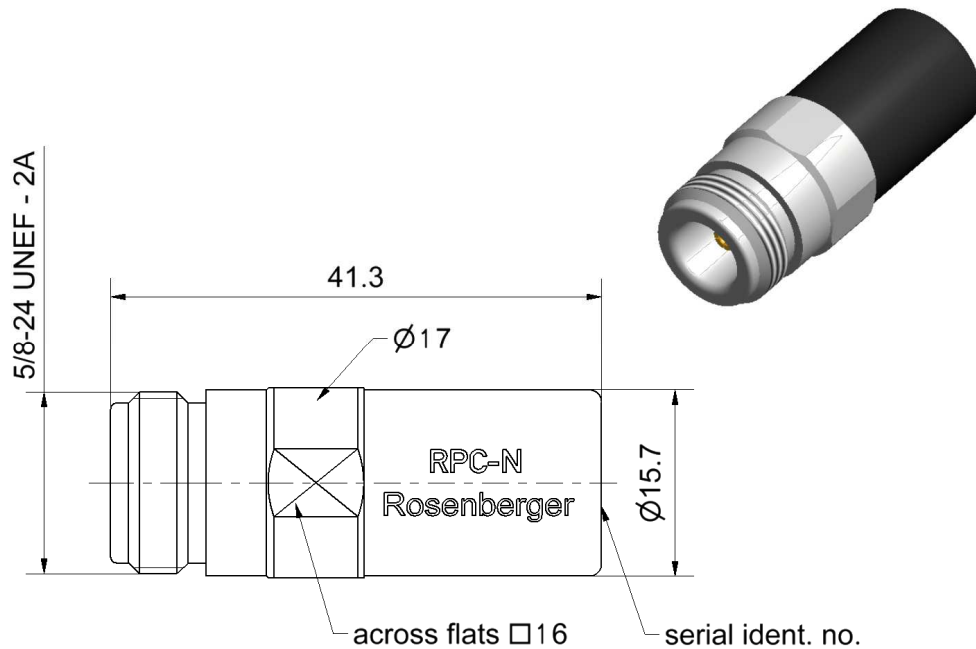

All dimensions are in mm; tolerances according to ISO 2768 m-H

Interface

According to IEC 61169-16

Documents

Application note AN001 "Calibration Services"

Material and plating

Connector parts

Center conductor
Outer conductor
Dielectric
Substrate

Material

CuBe
Stainless steel
PPE
Al₂O₃

Plating

Gold, min. 1.27 µm, over nickel
Passivated

Dieses Dokument ist urheberrechtlich geschützt • This document is protected by copyright • Rosenberger Hochfrequenztechnik GmbH & Co. KG

RF_35/09;14/6.2

RPC-N
50 Ω

Calibration Load
Jack

05K150-C10S3

Electrical data

Frequency range	DC to 18 GHz
Return loss	≥ 45 dB, DC to 4 GHz ≥ 32 dB, 4 GHz to 8 GHz ≥ 30 dB, 8 GHz to 18 GHz
DC Resistance	50 Ω ± 0.25 Ω
Power handling	≤ 1 W

Mechanical data

Mating cycles	≥ 500
Maximum torque	1.70 Nm
Recommended torque	1.10 Nm
Gauge	5.22 mm to 5.26 mm

General standard definitions

For proper operation the vector network analyzer (VNA) needs a model describing the electrical behaviour of this calibration standard. The different models, units, and terms used will depend on the VNA type and they will have to be entered into the VNA. All values are based on typical geometry and plating.

Offset Z_0 / Impedance / Z_0	50 Ω
Offset Delay	0.0000 ps
Length (electrical) / Offset Length	0.00 mm
Offset Loss	0.00 GΩ/s
Loss	0.0000 dB/√GHz

Environmental data

Operating temperature range ¹	+20 °C to +26 °C
Rated temperature range of use ²	0 °C to +50 °C
Storage temperature range	-40 °C to +85 °C

RoHS compliant

¹ Temperature range over which these specification are valid.

² This range is underneath and above the operating temperature range, within the calibration load is fully functional and could be used without damage.

Dieses Dokument ist urheberrechtlich geschützt • This document is protected by copyright • Rosenberger Hochfrequenztechnik GmbH & Co. KG

RF_35/09;14/6.2