

THIRD ANGLE PROJ.

REVISIONS

REV	DESCRIPTION	DATE	ECO	APPR
--	RELEASED TO MFG.	-----	-----	-----
U	REDRAWN IN PRO E, ADDED COD	1/14/13	48616	RAK

- NOTES:
- MATERIALS AND FINISHES:  
 BODY - BRASS, NICKEL PLATING  
 GASKET - SILICONE RUBBER  
 CHAIN - BRASS, NICKEL PLATING  
 RIVET - BRASS, NICKEL PLATING
  - PACKAGING:  
 A. QUANTITY: SINGLE PACK  
 B. MARKING: BAG TO BE MARKED  
 "AMPHENOLRF 82-106, AND DATE CODE"

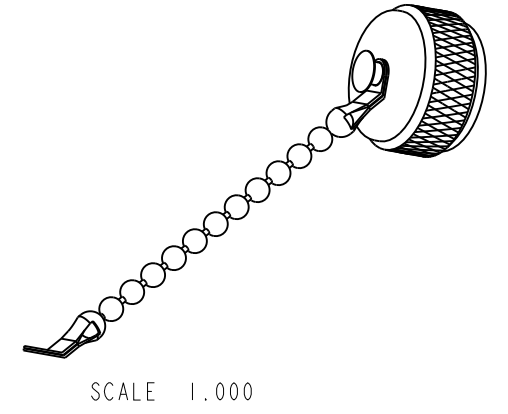
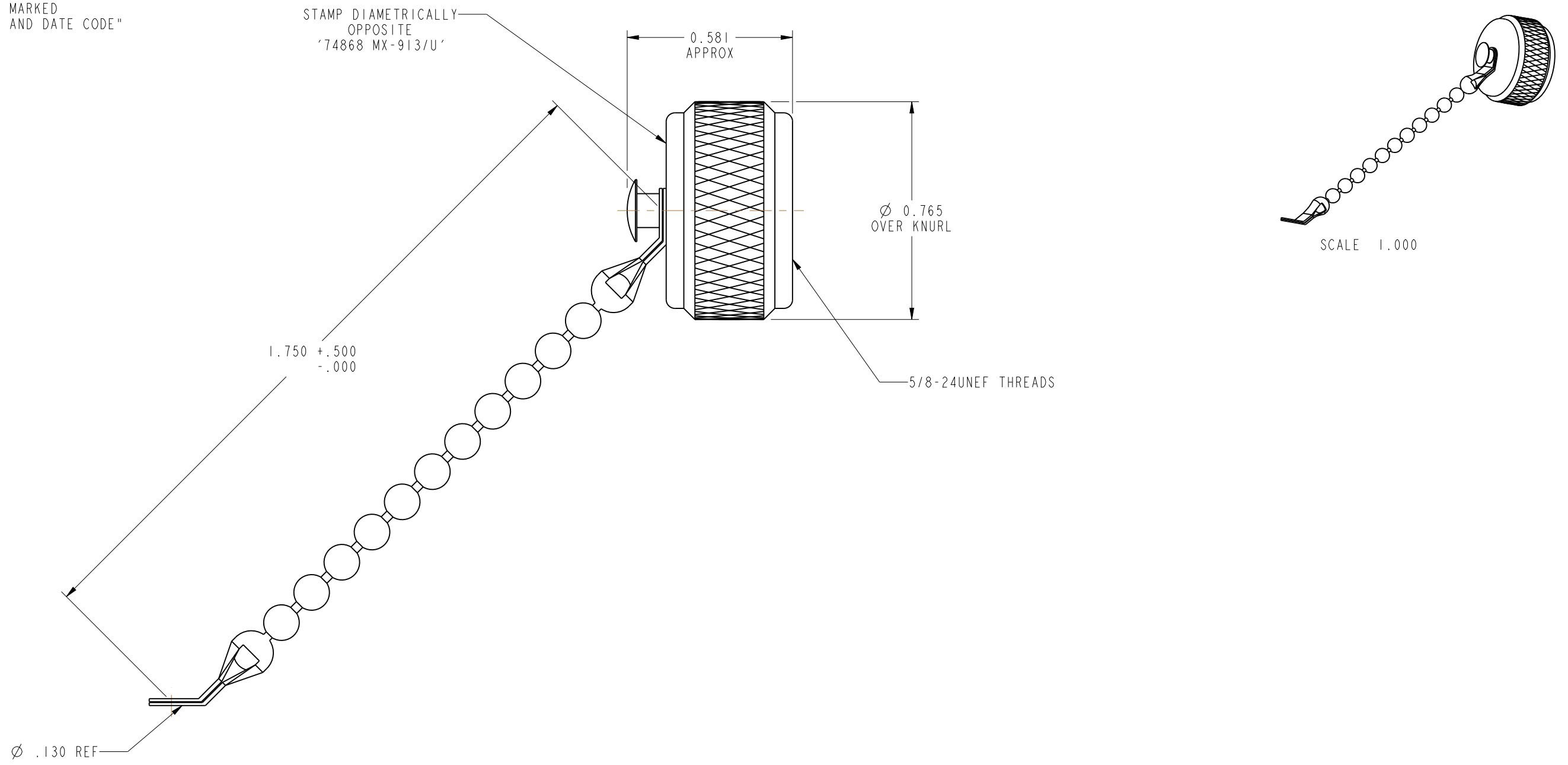

**CUSTOMER OUTLINE DRAWING**  
 ALL OTHER SHEETS ARE FOR INTERNAL USE ONLY

UNLESS OTHERWISE SPECIFIED, DIMENSIONS ARE IN INCHES AND TOLERANCES ARE: 2 PLACE DECIMAL 3 PLACE DECIMAL ANGLES ±.015 (0,381 mm) ±.005 (0,127 mm) ± 1°	MATERIAL SEE NOTES	DRAWN ABHAYA KISHORE	DATE 30-May-11	TITLE TYPE N CAP & CHAIN MX - 913/U	Amphenol RF www.amphenolrf.com
	REFERENCE	ENGINEER ABHAYA KISHORE	DATE 30-May-11		
NOTICE - These drawings, specifications, or other data (1) are, and remain the property of Amphenol corp. (2) must be returned upon request; and (3) are confidential and not to be disclosed to any person other than those to whom they are given by Amphenol Corp. the furnishing of these drawings, specifications, or other data by Amphenol Corp., or to any other person to anyone for any purpose is not to be regarded by implication or otherwise in any manner licensing, granting rights to permitting such holder or any other person to manufacture, use or sell any product, process or design, patented or otherwise, that may in any way be related to or disclosed by said drawings, specifications, or other data.	CONFIGURATION LEVEL:	APPROVED K. CAPOZZI	DATE 1/14/13	SCALE: 2.5:1.0	SHEET 2 OF 2
	FINISH	CAD FILE	DWG SIZE B	REV U	DRAWING NO.82-106 ITEM NO.82-106 PART NO.82-106