

- NOTES:
- MATERIALS AND FINISHES:
 BODY - BRASS, WHITE BRONZE PLATING
 CONTACT - BeCu & BRASS, SILVER PLATING
 INSULATOR - PTFE, NATURAL
 INSULATOR BEAD - PTFE, NATURAL
 GASKET - SILICONE RUBBER, RED
 LOCKWASHER - BRASS, WHITE BRONZE PLATING
 HEX NUT - BRASS, WHITE BRONZE PLATING
 - ELECTRICAL:
 A. IMPEDANCE: 50 OHM
 B. FREQUENCY RANGE: DC - 18 GHz
 C. VSWR(RETURN LOSS): 1.15 MAX. @ DC - 6 GHz
 1.20 MAX. @ 6 - 12 GHz
 1.25 MAX. @ 12 - 18 GHz
 D. DIELECTRIC WITHSTANDING VOLTAGE: 1000 VRMS, MIN.
 E. INTERMODULATION 3rd ORDER: -150dBc @2X20W
 - MECHANICAL:
 A. DURABILITY: 500 CYCLES MIN.
 B. TEMPERATURE RANGE: -65° C TO +165° C
 C. RECOMMENDED PANEL TORQUE: 30 IN-LBS
 - INDICATES CABLE ENTRY DIMENSIONS
 - ASSEMBLY INSTRUCTIONS:
 A. FOR SEMI-RIGID CABLE, THERMALLY CYCLE ACCORDING TO MANUFACTURER'S SPECIFICATIONS.
 B. STRIP CABLE AND INSERT THROUGH SHRINK TUBE.
 C. INSERT INSULATOR BEAD OVER CENTER CONDUCTOR AND SOLDER BULLET CONTACT.
 D. INSERT CABLE AND BULLET CONTACT INTO BODY ASSEMBLY UNTIL CABLE BOTTOMS.
 APPROX. 2.5 MM OF CABLE OUTER CONDUCTOR SHOULD BE INSERTED.
 E. SOLDER BODY ONTO CABLE. 250 WATT SOLDERING IRON RECOMMENDED. USE OF FLUX RECOMMENDED.
 - PACKAGING:
 A. QUANTITY: SINGLE PACK
 B. MARKING: BAG TO BE MARKED
 "AMPHENOL, 82-6766, AND DATE CODE"

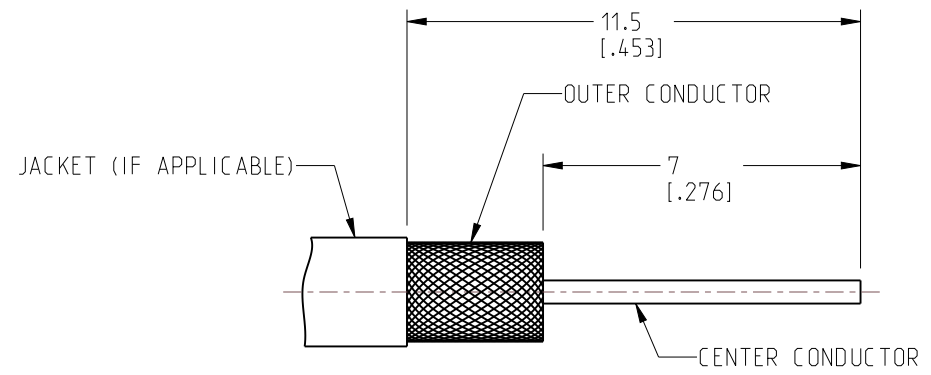

RECOMMENDED CABLE STRIPPING DIMENSIONS

REVISIONS				
REV	DESCRIPTION	DATE	ECN	APPR
A	RELEASE TO MFG.	12-JUL-21	15804	SH

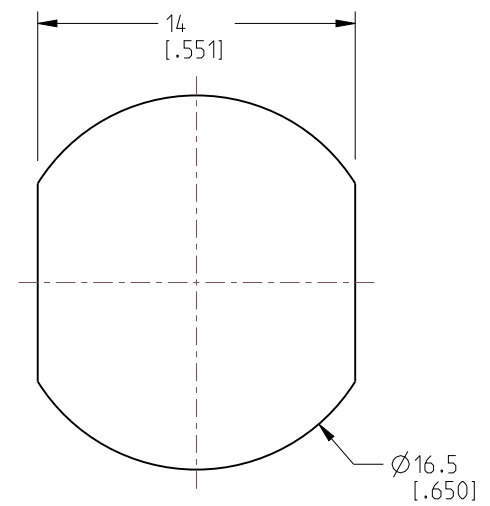
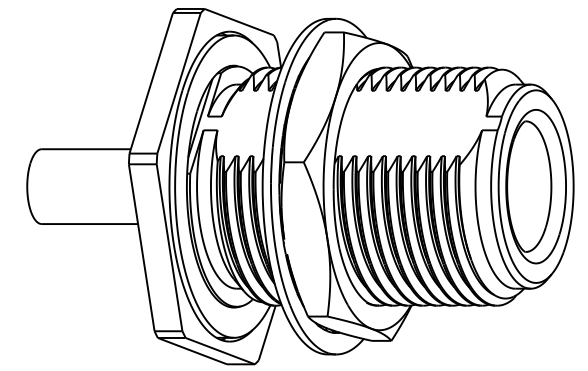

RECOMMENDED MOUNTING HOLE

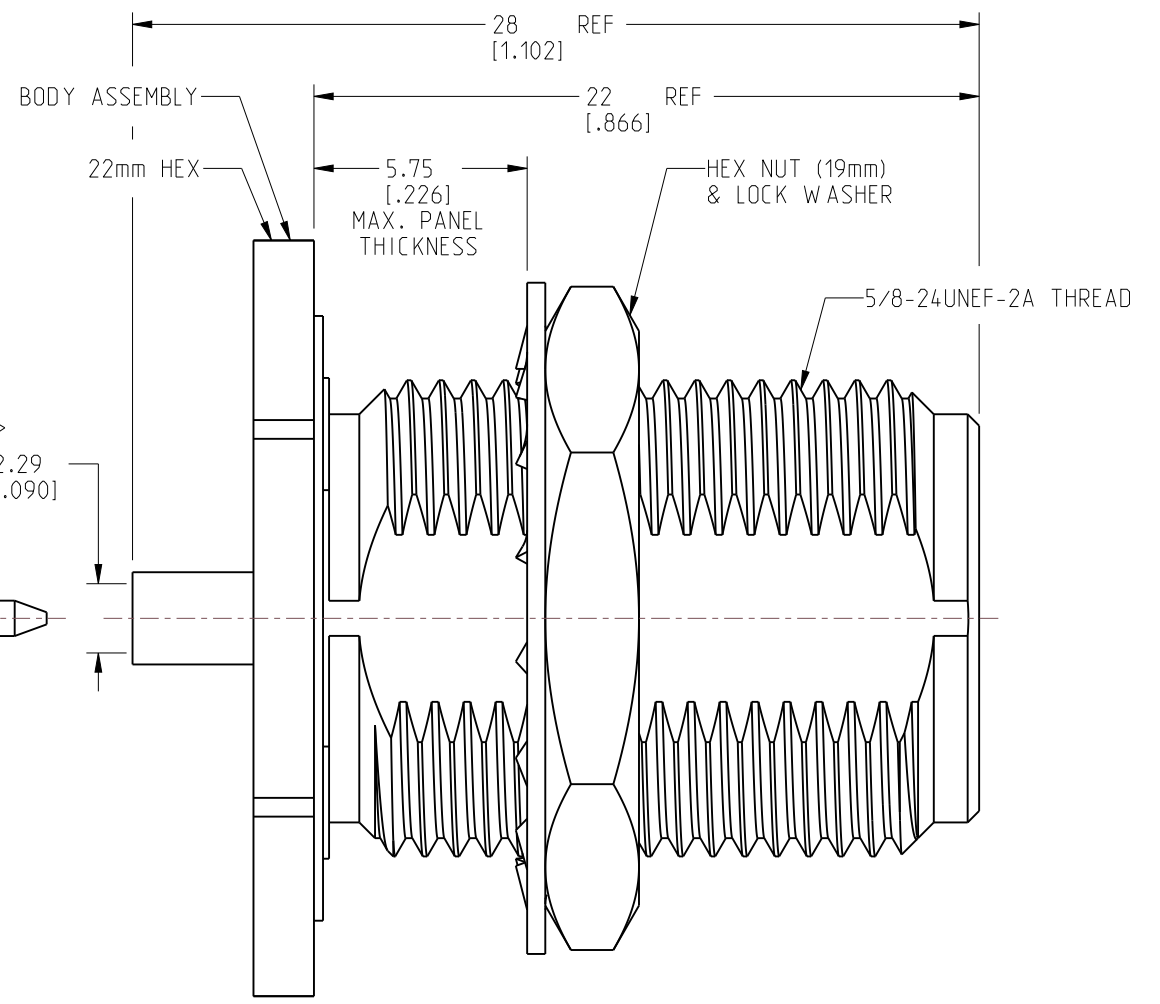
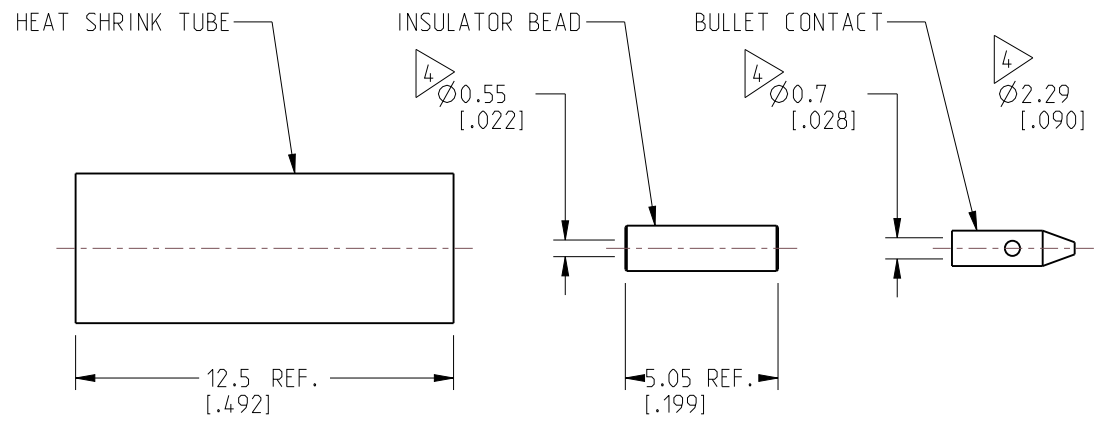

CUSTOMER OUTLINE DRAWING
 ALL OTHER SHEETS ARE FOR INTERNAL USE ONLY

NOTICE: These drawings, specifications, or other data (1) are, and remain the property of Amphenol corp. (2) must be returned upon request; and (3) are confidential and not to be disclosed to any person other than those to whom they are given by Amphenol Corp. The furnishing of these drawings, specifications, or other data by Amphenol Corp., or to any other person to anyone for any purpose is not to be regarded by implication or otherwise in any manner licensing, granting rights to permitting such holder or any other person to manufacture, use or sell any product, process or design, patented or otherwise, that may in any way be related to or disclosed by said drawings, specifications, or other data.

THIRD ANGLE PROJ. REFERENCE EAR# 10072

UNLESS OTHERWISE SPECIFIED DIMENSIONS ARE METRIC (INCHES) AND TOLERANCES ARE:
 <0.5mm = ±0.05mm [$<0.020 = \pm 0.002$]
 >0.5 - 6mm = ±0.1mm [$>0.020 - 0.236 = \pm 0.004$]
 >6.00 - 30mm = ±0.2mm [$>0.236 - 1.181 = \pm 0.008$]
 >30.00 - 120mm = ±0.3mm [$>1.181 - 4.725 = \pm 0.012$]

ANGLES = ±1°

MATERIAL: SEE NOTES
 ENGINEER: E.W.U
 DATE: 28-JUN-21

TITLE: 18 GHz TYPE N BHD JACK
 IP67 FOR .085"
 SEMI-RIGID & CONFORMABLE

SHEET NO. 2 OF 2 SCALE: 4.0:1.0

Amphenol RF

SIZE: B	DRAWING NO. 82-6766	REV: A
	ITEM NO. 82-6766	
	PART NO. 82-6766	