

REVISION					
ZONE	LTR	ECN	DESCRIPTION	DATE	APPROVED
	D	41239	ADD .325 MIN TIN DIMENSION	1/16/02	TL

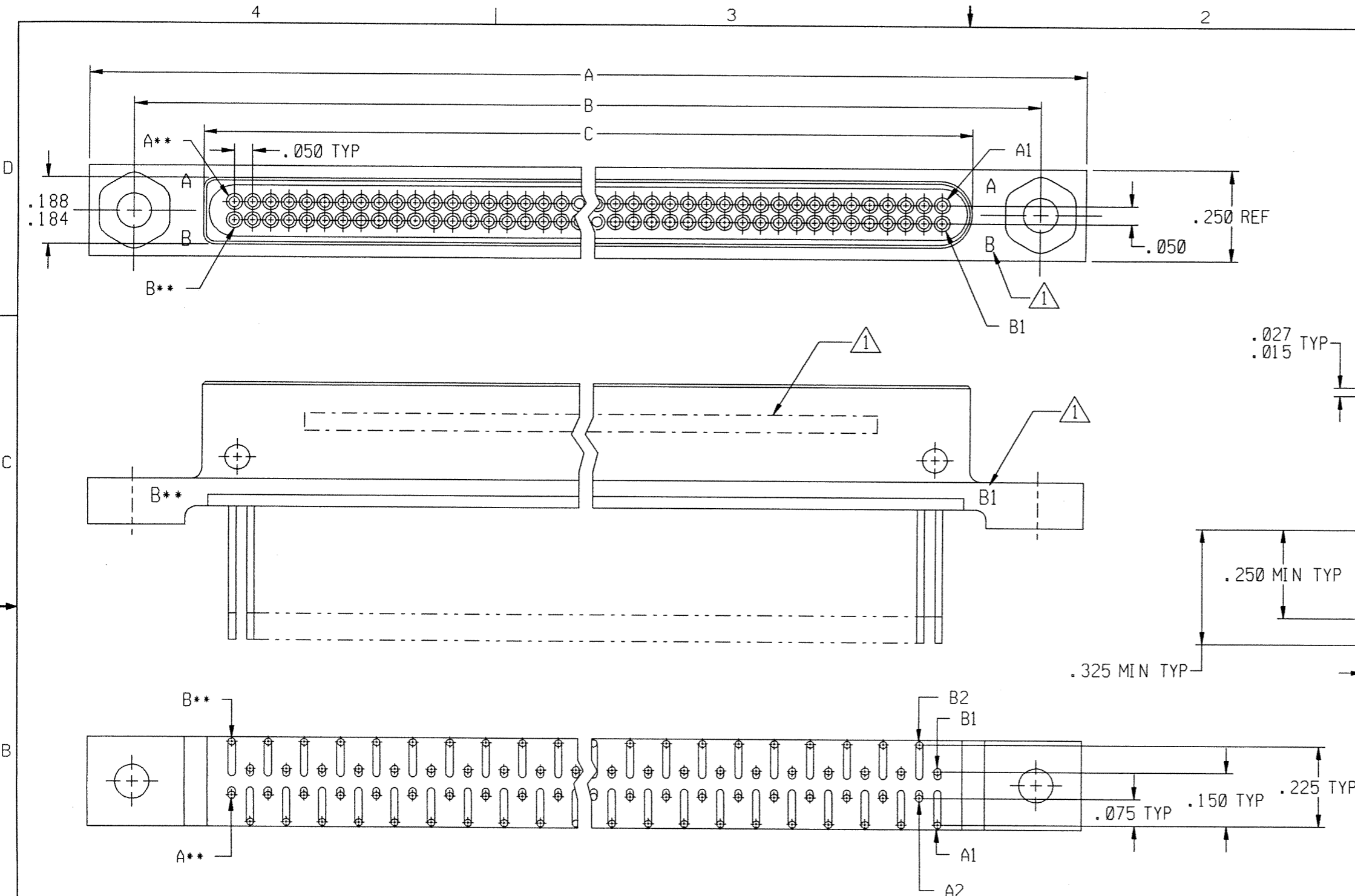

CAVITY NO.	PART NUMBER	A	B	C
40	095-0087-2101	1.750	1.500	1.119/1.122
44	095-0087-3102	1.850	1.600	1.219/1.222
80	095-0087-5102	2.750	2.500	2.119/2.122
110	095-0087-6102	3.500	3.250	2.869/2.872
128	095-0087-7127	3.950	3.700	3.319/3.322
152	095-0087-4001	4.550	4.300	3.919/3.922

NOTES: UNLESS OTHERWISE SPECIFIED

1. MARK PER TIS (\*\* : 1/2 OF TOTAL NUMBER OF CAVITIES, EX: \*\* = 64 FOR 128 CAVIITES).
2. CRIMP LEADS INTO CONTACTS PER MEP 302-05.
3. FORM TERMINAL WIRES AS SHOWN. NO SCRATCHES EXPOSING BASE METAL PERMITTED ON WIRES AFTER FORMING.
4. THE 90° BEND IN THE TERMINAL WIRES SHALL NOT EXTEND BELOW THE PLANE OF THE MOUNTING FLANGE.
5. EPOXY AS SHOWN USING P/N: 194-8102-6215/6225.
6. TWO POLARIZING KEYS SUPPLIED UNASSEMBLED.

UNLESS OTHERWISE SPECIFIED DIMENSIONS ARE IN INCHES. TOLERANCE ARE:

FRACTIONS	DECIMALS	ANGLES
± 1/8	.XX ± .01 .XXX ± .005	± 2°

APPROVALS	
SIGNATURE	DATE
DRAWN BY: <i>TWYL</i>	1/16/02
P. E.	
M. E.	
G. A.	

**MICRODOT CONNECTORS**  
A DIVISION OF UNI-STAR INDUSTRIES INC.  
306 PASADENA AVE., SO. PASADENA, CA 91030

CONNECTOR, PLUG,  
METAL SHELL MASTER  
MCEM1-\*\*\*\*-PZ

PROD CODE 844  
CODE M

THIS DOCUMENT IS THE PROPERTY OF MICRODOT CONNECTORS, A DIVISION OF UNI-STAR INDUSTRIES INC. USE OF THIS DOCUMENT OR ANY PART THEREOF IS STRICTLY FORBIDDEN WITHOUT THE EXPRESS WRITTEN PERMISSION OF MICRODOT CONNECTORS, A DIVISION OF UNI-STAR INDUSTRIES INC.

SIZE: B CODE IDENT NO. 98278 DRAWING NO. 095-0000-0462  
SCALE: NONE SHEET 1 OF 1