

RPC-2.40 Calibration Load Jack

**09K150-C10S3**

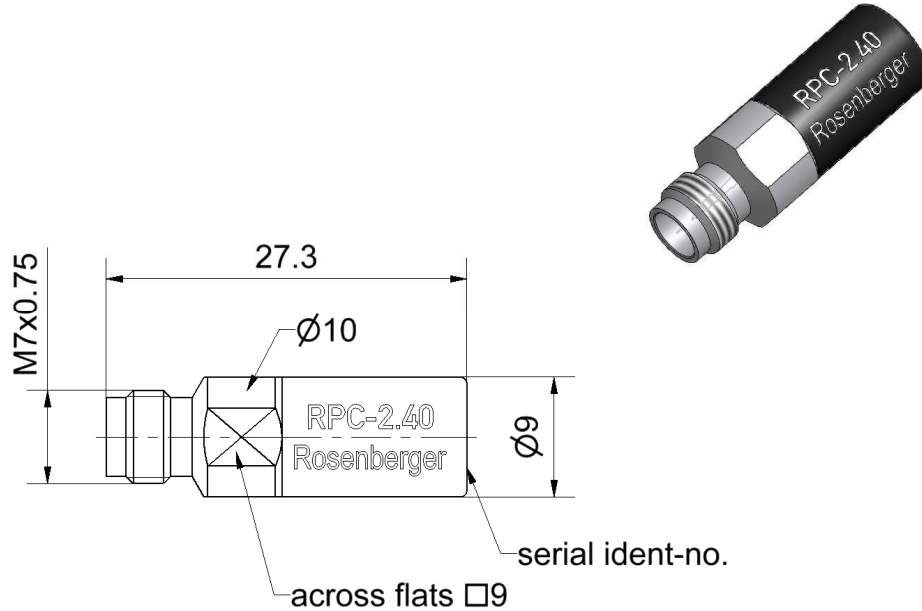

All dimensions are in mm; tolerances according to ISO 2768 m-H

**Interface**

According to IEC 61169-40  
Mechanically compatible with RPC-1.85

**Documents**

Application note AN001 "Calibration Services"

**Material and plating**

**Connector parts**

Center conductor	<b>Material</b> CuBe	<b>Plating</b> Gold, min. 1.27 µm, over nickel
Outer conductor	Stainless steel	Passivated
Dielectric	PS	
Substrate	Al <sub>2</sub> O <sub>3</sub>	

Dieses Dokument ist urheberrechtlich geschützt • This document is protected by copyright • Rosenberger Hochfrequenztechnik GmbH & Co. KG  
RF\_35/09.14/6.2

RPC-2.40 Calibration Load Jack

**09K150-C10S3**

**Electrical data**

Frequency range	DC to 50 GHz
Return loss	≥ 36 dB, DC to 4 GHz ≥ 30 dB, 4 GHz to 26.5 GHz ≥ 22 dB, 26.5 GHz to 50 GHz
DC Resistance	50 Ω ± 0.25 Ω
Power handling	≤ 0.5 W

**Mechanical data**

Mating cycles	≥ 500
Maximum torque	1.65 Nm
Recommended torque	0.90 Nm
Gauge	0.00 mm to 0.03 mm

**General standard definitions**

For proper operation the vector network analyzer (VNA) needs a model describing the electrical behaviour of this calibration standard. The different models, units, and terms used will depend on the VNA type and they will have to be entered into the VNA. All values are based on typical geometry and plating.

Offset $Z_0$ / Impedance / $Z_0$	50 Ω
Offset Delay	0.0000 ps
Length (electrical) / Offset Length	0.000 mm
Offset Loss	0.00 GΩ/s
Loss	0.0000 dB/√GHz

**Environmental data**

Operating temperature range <sup>1</sup>	+20 °C to +26 °C
Rated temperature range of use <sup>2</sup>	0 °C to +50 °C
Storage temperature range	- 40 °C to +85 °C

RoHS compliant

<sup>1</sup> Temperature range over which these specification are valid.

<sup>2</sup> This range is underneath and above the operating temperature range, within the calibration load is fully functional and could be used without damage.

Dieses Dokument ist urheberrechtlich geschützt • This document is protected by copyright • Rosenberger Hochfrequenztechnik GmbH & Co. KG

RF\_35/09.14/6.2