

RPC-2.40 Short Circuit Plug

09S12S-000S3

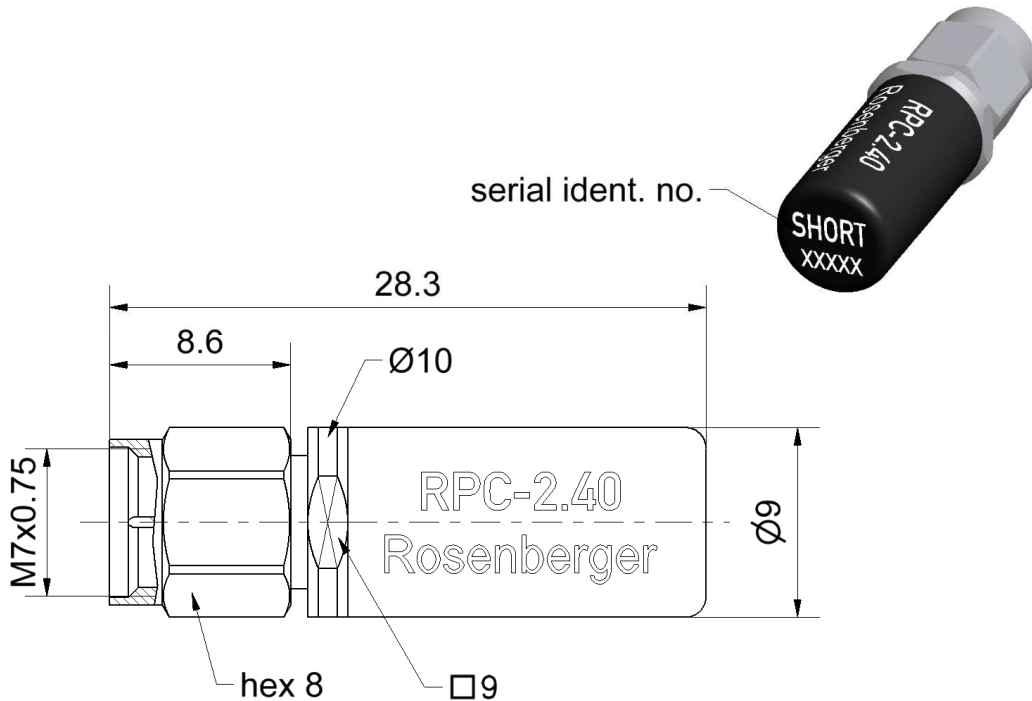

All dimensions are in mm; tolerances according to ISO 2768 m-H

**Interface**

According to IEC 61169-40  
Mechanically compatible with RPC-1.85

**Documents**

Application note AN001 "Calibration Services"

**Material and plating**

**Connector parts**

Center conductor	Material	CuBe	Plating	Gold, min. 1.27 µm, over nickel
Outer conductor		Stainless steel		Passivated
Coupling nut		Stainless steel		Passivated

Dieses Dokument ist urheberrechtlich geschützt • This document is protected by copyright • Rosenberger Hochfrequenztechnik GmbH & Co. KG

RF\_35/05:10/6.0

**Electrical data**

Frequency range	DC to 50 GHz
Return loss	≤ 0.15 dB, DC to 4 GHz
	≤ 0.20 dB, 4 GHz to 26.5 GHz
	≤ 0.25 dB, 26.5 GHz to 50 GHz
Error from nominal phase <sup>1</sup>	≤ 1.5°, DC to 4 GHz
	≤ 3.0°, 4 GHz to 26.5 GHz
	≤ 4.5°, 26.5 GHz to 50 GHz

<sup>1</sup> The nominal phase is defined by the Offset Delay, the Offset Loss and the Short Inductance

**Mechanical data**

Mating cycles	≥ 500
Maximum torque	1.65 Nm
Recommended torque	0.90 Nm
Gauge	0.00 mm to 0.03 mm

**General standard definitions**

For proper operation the vector network analyzer (VNA) needs a model describing the electrical behaviour of this calibration standard. The different models, units, and terms used will depend on the VNA type and they will have to be entered into the VNA. All values are based on typical geometry and plating.

Offset $Z_o$ / Impedance / $Z_o$	50 $\Omega$
Offset Delay	23.3500 ps
Length (electrical) / Offset Length	7.00 mm
Offset Loss	3.50 G $\Omega$ /s
Loss	0.0142 dB/ $\sqrt{\text{GHz}}$
Short Inductance <sup>2</sup>	

<sup>2</sup> Short Inductance are determined individually for each Short Circuit and are documented in a Calibration Certificate.

**Environmental data**

Operating temperature range <sup>3</sup>	+20 °C to +26 °C
Rated temperature range of use <sup>4</sup>	0 °C to +50 °C
Storage temperature range	-40 °C to +85 °C

RoHS compliant

<sup>3</sup> Temperature range over which these specifications are valid.

<sup>4</sup> This range is underneath and above the operating temperature range, within the Short Circuit is fully functional and could be used without damage.