

LOC		DIST		REVISIONS			
AD	00	REV	DATE	BY	CHK	APPV	
E3		REVISED PER ECO-11-005033	28MAR11	RK	HMR		
F		ECR-12-010652	25NOV12	SY	AC		

CONNECTOR ASSEMBLY EXAMPLARY LOADED

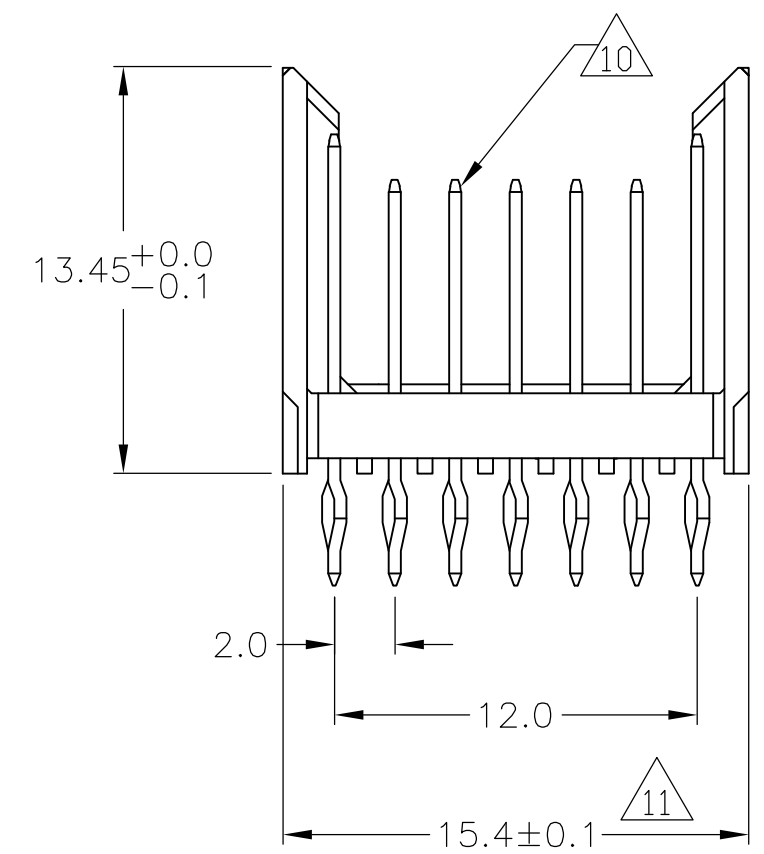
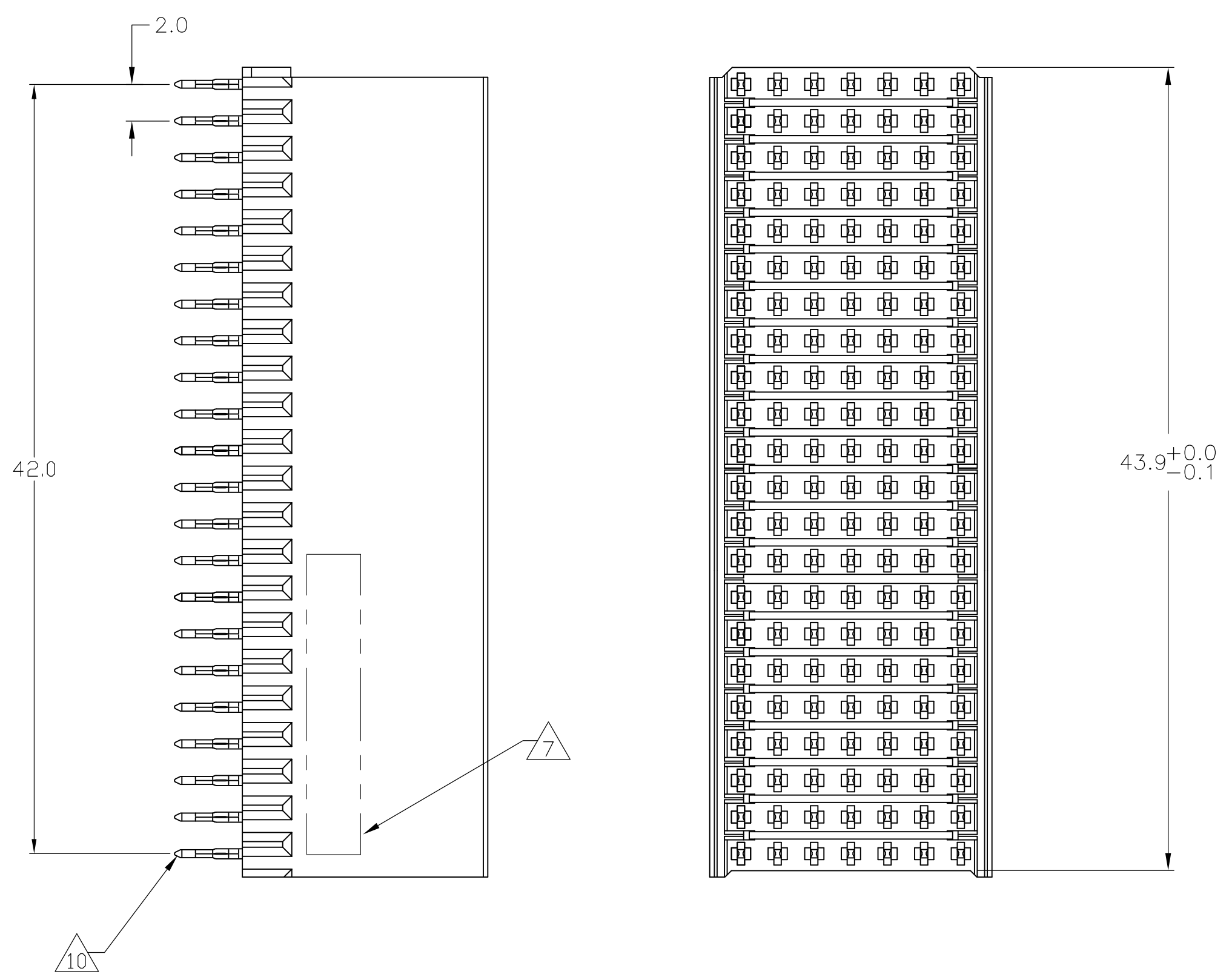

CONTACT DIMENSIONS

SCALE 5:1

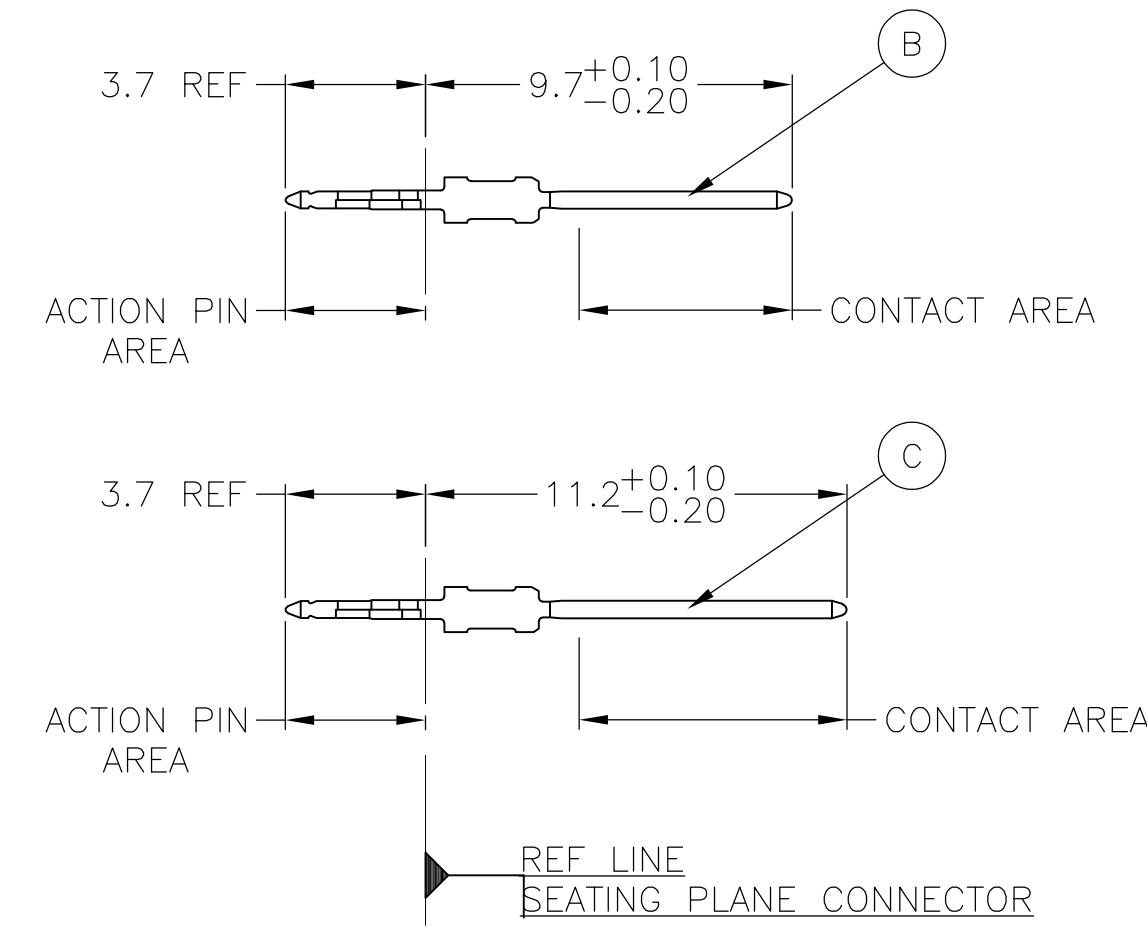

CONTACT LAYOUT

	z	a	b	c	d	e	f
1	C	B	B	B	B	B	C
2	C	B	B	B	B	B	C
3	C	B	B	B	B	B	C
4	C	B	B	B	B	B	C
5	C	B	B	B	B	B	C
6	C	B	B	B	B	B	C
7	C	B	B	B	B	B	C
8	C	B	B	B	B	B	C
9	C	B	B	B	B	B	C
10	C	B	B	B	B	B	C
11	C	B	B	B	B	B	C
12	C	B	B	B	B	B	C
13	C	B	B	B	B	B	C
14	C	B	B	B	B	B	C
15	C	B	B	B	B	B	C
16	C	B	B	B	B	B	C
17	C	B	B	B	B	B	C
18	C	B	B	B	B	B	C
19	C	B	B	B	B	B	C
20	C	B	B	B	B	B	C
21	C	B	B	B	B	B	C
22	C	B	B	B	B	B	C

RECOMMENDED PCB-HOLE LAYOUT COMPONENT SIDE SHOWN

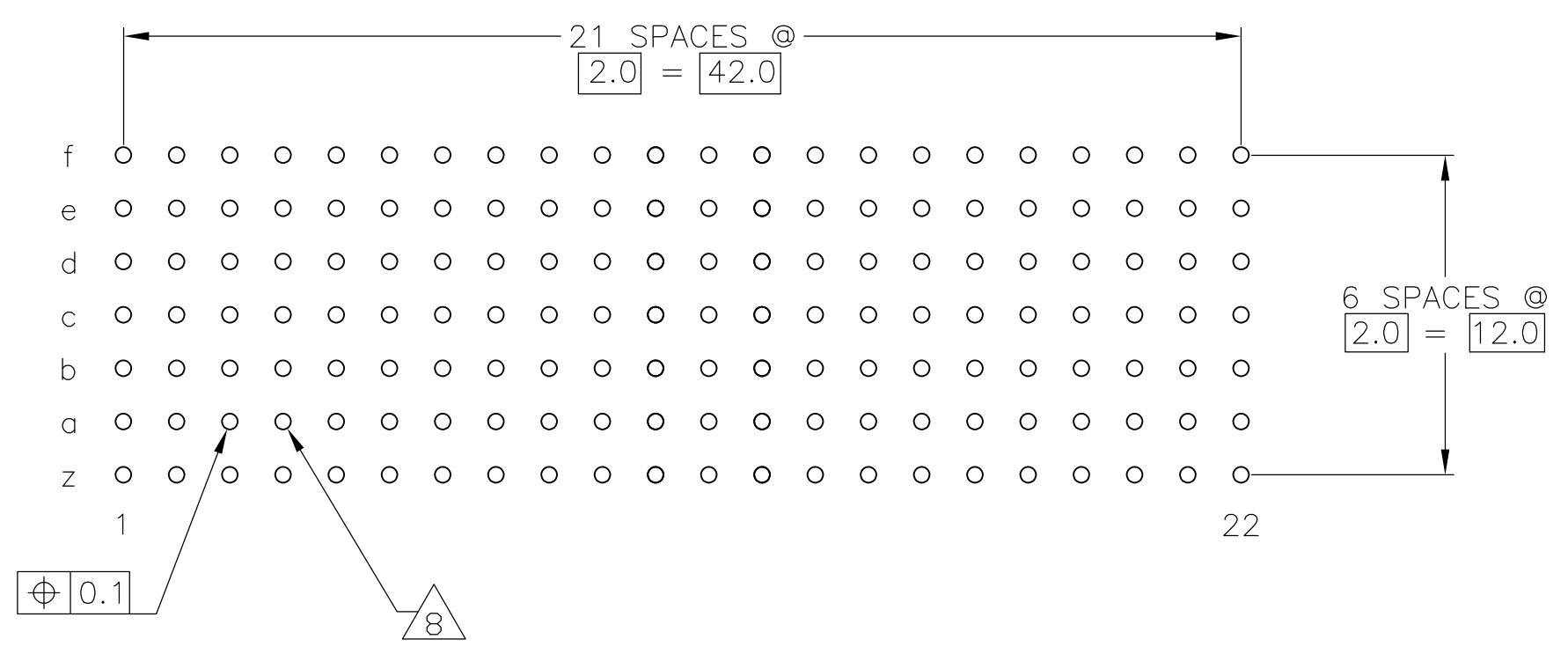

PLATED THRU HOLES PARAMETERS

REFERENCE APPLICATION SPECIFICATION

	2 5 12 13	3-188835-1
	2 3 13	3-188835-0
	2 6 12	1-188835-9
OBSOLETE	2 5 12	-188835-9-
	2 4	188835-4
	2 3	188835-1
	FINISH	PART NUMBER

THIS DRAWING IS A CONTROLLED DOCUMENT.

DIMENSIONS:	TOLERANCES UNLESS OTHERWISE SPECIFIED:	DIN B CARBO 130DEC05	TE Connectivity
mm	0. PLC ± -	CHK G SKIPPER 130DEC05	
	1. PLC ± 0.1	APPV G SKIPPER 130DEC05	MALE ASSEMBLY, Z-PACK 2mm HM, TYPE B
	2. PLC ± -	PRODUCT SPEC	108-19082
	3. PLC ± -	APPLICATION SPEC	114-19029
	4. PLC ± -	SIZE	A1
	ANGLES ± -	WEIGHT	00779
MATERIAL	FINISH SEE TABLE	RESTRICTED TO	188835
		CUSTOMER DRAWING	SCALE 4:1 SHEET 1 OF 2 REV F

THIS DRAWING IS UNPUBLISHED. RELEASED FOR PUBLICATION
 © COPYRIGHT - By - ALL RIGHTS RESERVED.

LOC		DIST		REVISIONS				
P	LTR	DESCRIPTION	DATE	DN	APVD			
-	-	SEE SHEET 1	-	-	-			

- 1 MATERIAL:
CONTACT: PHOSPHOR BRONZE.
HOUSING: GLASS-FILLED POLYESTER.
- 2 GENERAL PLATING SPECIFICATION: UNDERPLATING
(ENTIRE CONTACT): 1.27µm MIN NICKEL AND ACTION
PIN: 0.5µm MIN TIN LEAD.
FOR PLATING OF MATING SURFACES SEE APPLICABLE
SPECIFICATION REFERENCE FOR EACH DASH NUMBER.
- 3 CONFORMS TO ALL TESTING ACCORDING TO IEC 61076-4-101
PERFORMANCE LEVEL 2.
- 4 CONFORMS TO ALL TESTING ACCORDING TO IEC 61076-4-101
PERFORMANCE LEVEL 1.
- 5 CONNECTOR TESTED AND QUALIFIED AGAINST TELCORDIA GR-1217-CORE QUALITY LEVEL 3,
CENTRAL OFFICE APPLICATIONS.
- 6 CONNECTOR TESTED AND QUALIFIED AGAINST TELCORDIA GR-1217-CORE QUALITY LEVEL 3,
UNCONTROLLED ENVIROMENT APPLICATIONS.
- 7 CONNECTOR MARKED WITH PART NUMBER AND DATE CODE.
ADDITIONAL CHARACTERS OR MARKINGS, AS WELL AS THE LOCATION OF THE MARKINGS,
MAY BE ADDED FOR TRACEABILITY BASED UPON MANUFACTURERS DISCRETION.
- 8 PLATED-THROUGH HOLES AT 2x2mm SQUARE GRID
PATTERN DEFINED BY CONTACT LAYOUT.
- 9 FOR ACTUAL PIN LOADING SEE "CONTACT LAYOUT".
- 10 FOR ACTUAL PIN DIMENSIONS SEE "CONTACT DIMENSIONS".
- 11 TO BE MEASURED AT BOTTOM OF SHROUD.
- 12 CONNECTOR LUBRICATED WITH BELCORE APPROVED LUBRICANT,
TECHNICAL REFERENCE: TR-NWT-001217 ISSUE 1, SEP 1992.
- 13 0.76µm MIN GOLD PLATING AT MATING SURFACES.

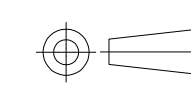
THIS DRAWING IS A CONTROLLED DOCUMENT.		DIN E CARBO 13DEC05	 TE Connectivity	
		CHK G SKIPPER 13DEC05		
DIMENSIONS: mm		TOLERANCES UNLESS OTHERWISE SPECIFIED:	NAME	
		0 PLC ± - 1 PLC ± 0.1 2 PLC ± - 3 PLC ± - 4 PLC ± - ANGLES ± ± -	PRODUCT SPEC 108-19082 APPLICATION SPEC 114-19029	
MATERIAL SEE SHEET 1	FINISH SEE SHEET 1	WEIGHT -	SIZE A1	CAGE CODE 00779
		DRAWING NO 188835		RESTRICTED TO -
		CUSTOMER DRAWING		SCALE 4:1 SHEET 2 OF 2 REV F