

LOC		DIST		REVISIONS			
GP	00	P	LTN	DESCRIPTION	DATE	DWN	APVD
		B		REVISED PER ECO-15-017919	04APR2016	AP	RP
		B1		ADD PN 2149490-9	17JUN2020	IT	SH

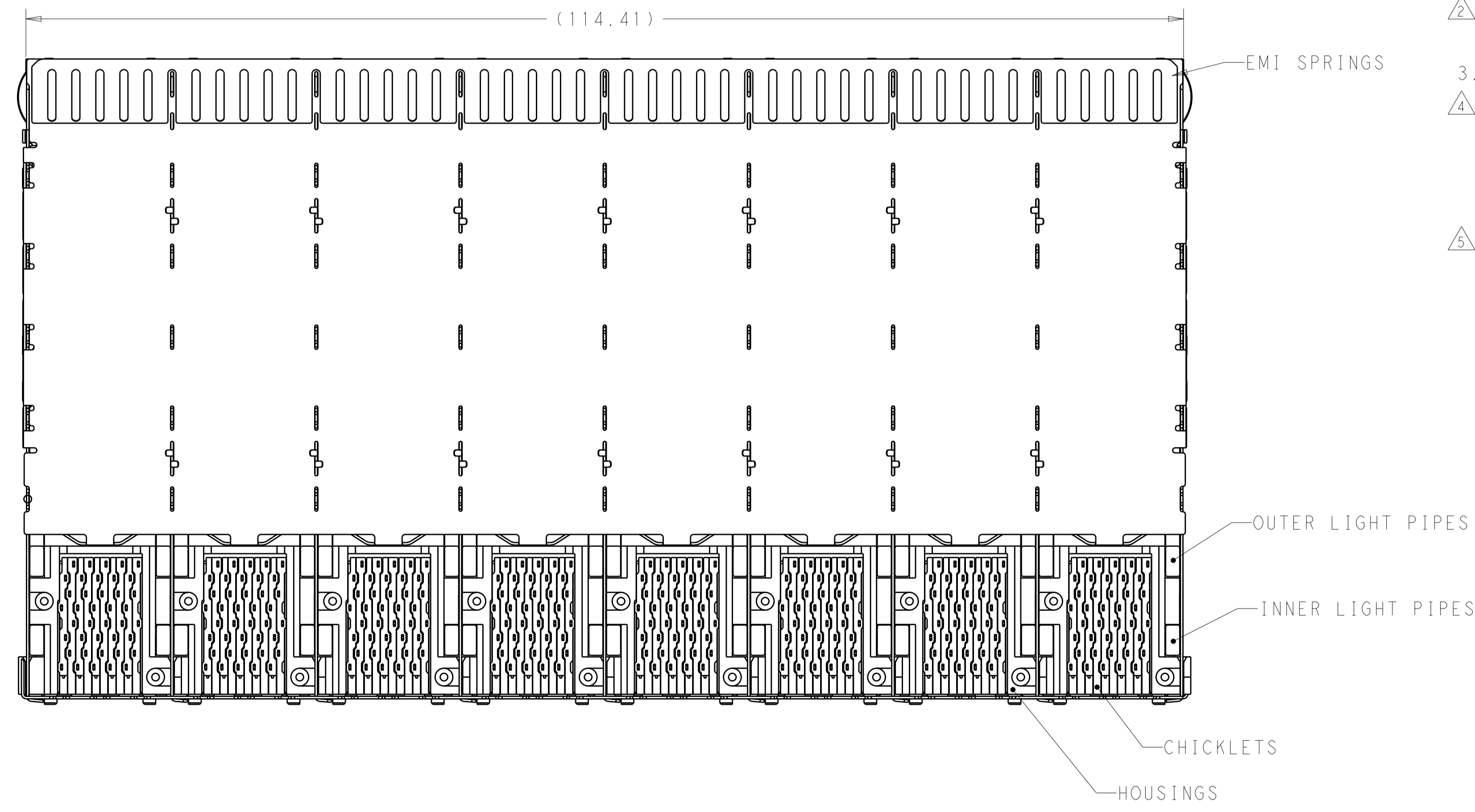
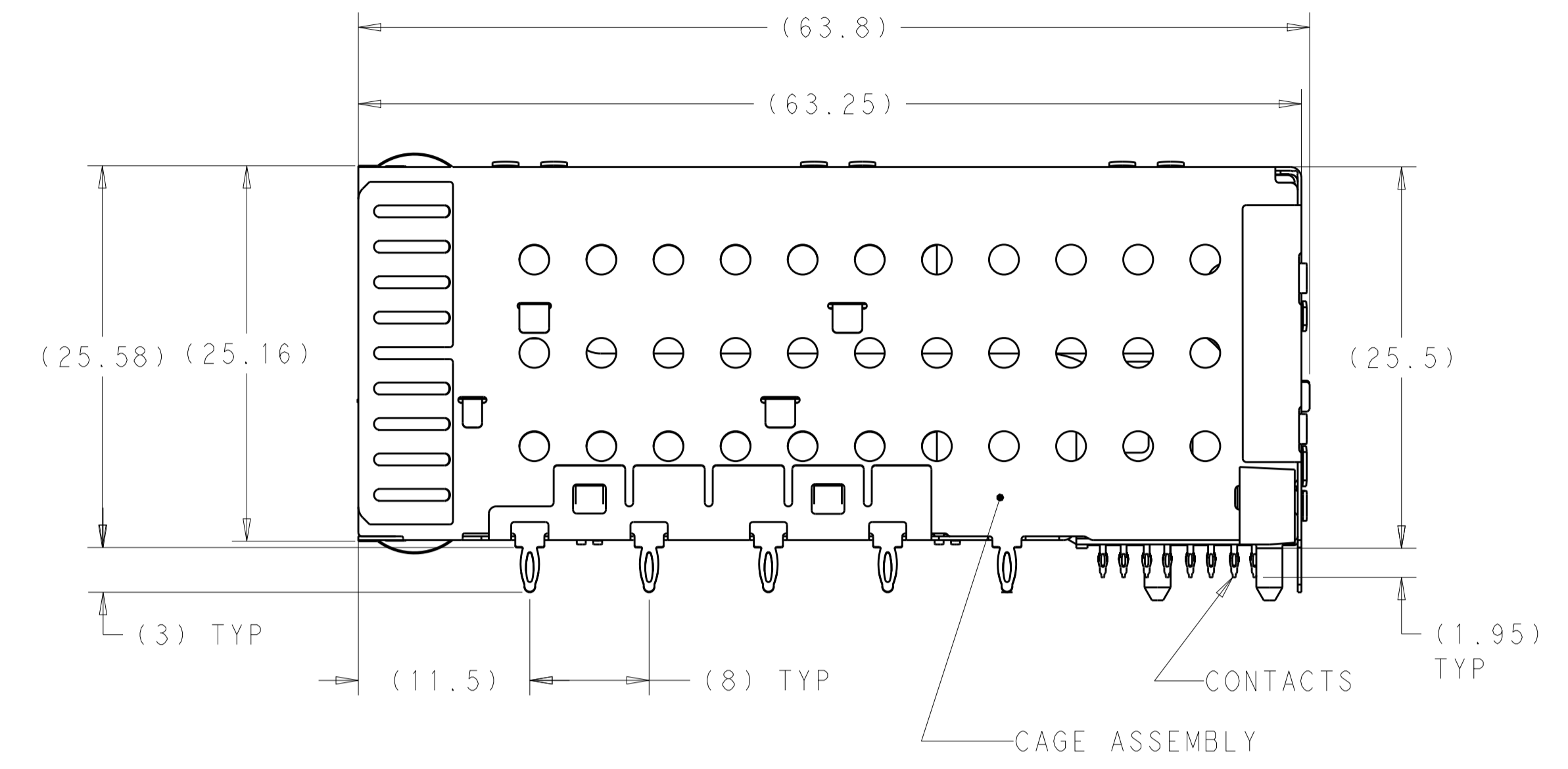
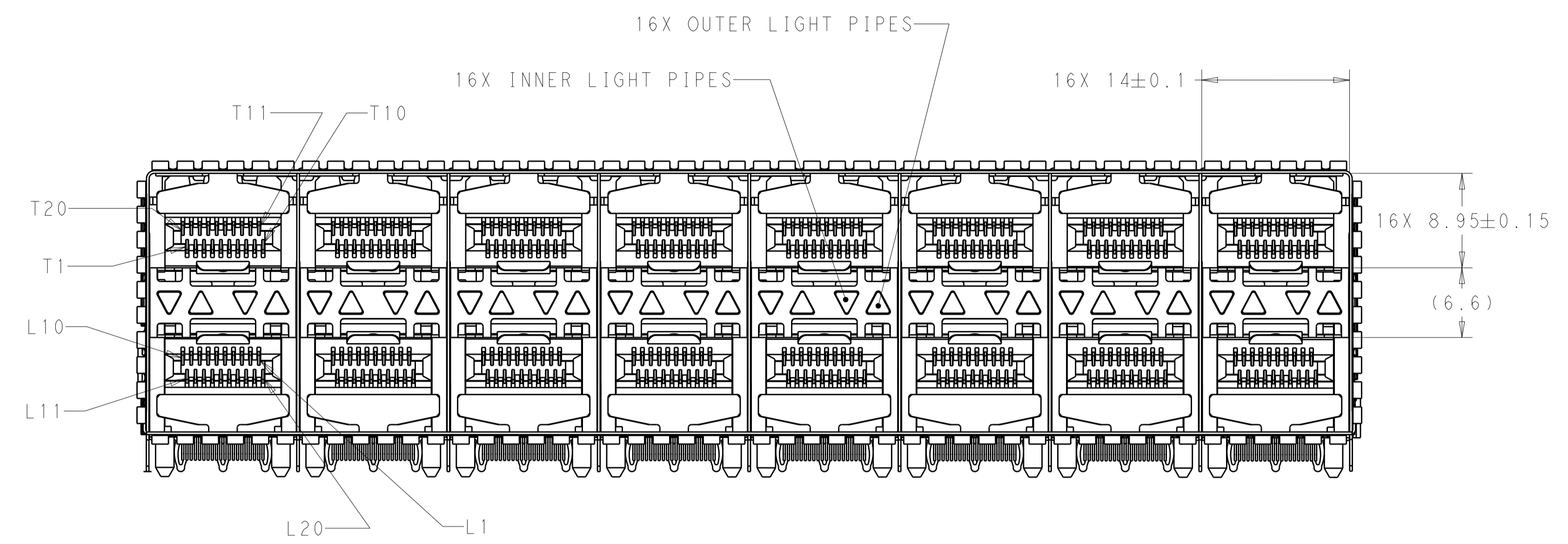

- ⚠ MATERIALS:
 CAGE ASSEMBLY- NICKEL SILVER ALLOY PER ASTM B 122.
 EMI SPRINGS- COPPER ALLOY.
 HOUSING- BLACK LCP, UL 94V-0 RATED.
 CHICKLET- BLACK LCP, UL 94V-0 RATED.
 LIGHT PIPE- POLYCARBONATE, CLEAR.
 CONTACT- COPPER ALLOY.
- ⚠ DATUM AND BASIC DIMENSIONS ESTABLISHED BY CUSTOMER.
- 3. MINIMUM PCB THICKNESS OF 1.5.
- ⚠ CONTACT FINISH- CONFORMS TO THE REQUIREMENTS OF TYCO ELECTRONICS PRODUCT SPECIFICATION 108-2331, BASED ON EIA/ECA-364-1000.01A, (CONTROLLED ENVIRONMENT APPLICATIONS) ON MATING INTERFACE, TIN-LEAD ON NEEDLE EYE.
- ⚠ CONTACT FINISH- CONFORMS TO THE REQUIREMENTS OF TYCO ELECTRONICS PRODUCT SPECIFICATION 108-2331, BASED ON EIA/ECA-364-1000.01A, (CONTROLLED ENVIRONMENT APPLICATIONS) ON MATING INTERFACE, TIN ON NEEDLE EYE.
- ⚠ FOR HOLE SIZE AND PLATINGS, SEE APPLICATION SPEC 114-13219.
- ⚠ THE ENTIRE AREA OF THE CONNECTOR FOOTPRINT, INDICATED BY THE DASHE LINE, TO BE CONSIDERED THE KEEPCUT AREA FOR COMPONENTS AND SIGNAL TRACES, TOP SIDE ONLY. TOP SIDE TRACES ALLOWED WITHIN CONNECTOR HOLE PATTERN.
- ⚠ LIGHT PIPE PAD LAYOUT IS FOR 0805 LOW PROFILE LED PACKAGE WITH A HEIGHT OF 0.8mm.
- ⚠ EMI SPRING FINISH: 0.8µm MINIMUM MATTE TIN OVER 0.8µm MINIMUM NICKEL, NONPLATED EDGES PERMISSIBLE.
- ⚠ ADDITIONAL COMPONENT LOCATED WITHIN LATCH PLATE FOR EMI SUPPRESSION.
- ⚠ EMI SPRING WELDING REINFORCED WITH MORE WELDING DOTS.

YES	NO	SUPERSEDED	ENHANCED EMI	FINISH	DESCRIPTION	PART NUMBER
⚠	⚠	⚠	⚠	⚠	NO LIGHT PIPES	1-2149490-8
					OUTER 2 LIGHT PIPES	1-2149490-7
					INNER 2 LIGHT PIPES	1-2149490-6
					4 LIGHT PIPES	1-2149490-5
⚠	⚠	⚠	⚠	⚠	INNER 2 LIGHT PIPES	2149490-9 ⚠
					NO LIGHT PIPES	2149490-8
					OUTER 2 LIGHT PIPES	2149490-7
					INNER 2 LIGHT PIPES	2149490-6
⚠	⚠	⚠	⚠	⚠	4 LIGHT PIPES	2149490-5
					NO LIGHT PIPES	2149490-4
					OUTER 2 LIGHT PIPES	2149490-3
					INNER 2 LIGHT PIPES	2149490-2
⚠	⚠	⚠	⚠	⚠	4 LIGHT PIPES	2149490-1

THIS DRAWING IS A CONTROLLED DOCUMENT. DIMENSIONING AND TOLERANCING PER ASME Y14.5M-2009.

STE TE Connectivity

CAGE AND PT CONNECTOR ASSEMBLY, WITH EMI SPRINGS, PRESS FIT, 2X8, STACKED SFP+

SCALE 3:1 SHEET 1 OF 4 REV B1

LOC		DIST		REVISIONS			
P	LTN	DESCRIPTION	DATE	DWN	APVD		

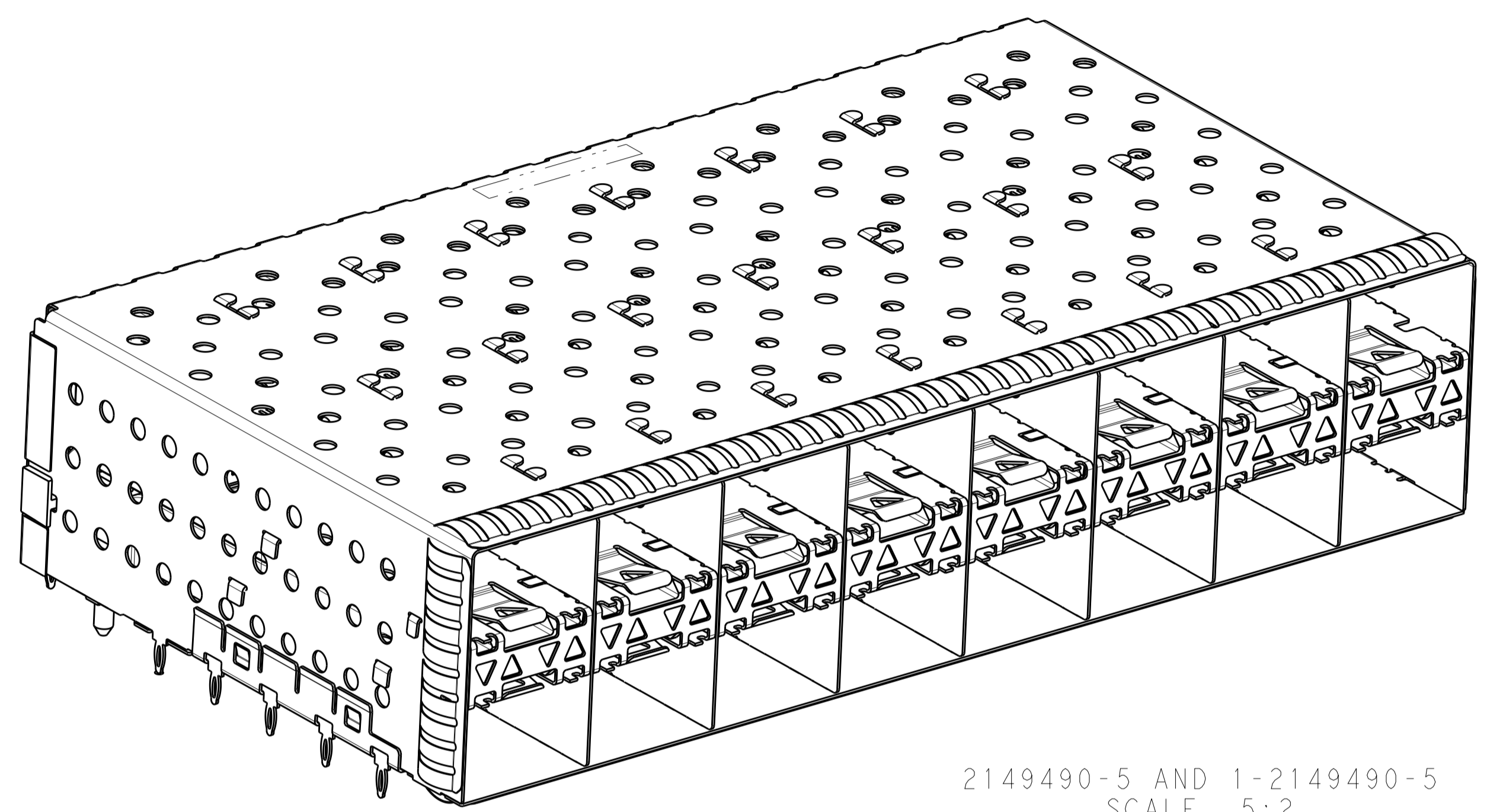

2149490-5 AND 1-2149490-5
 SCALE 5:2

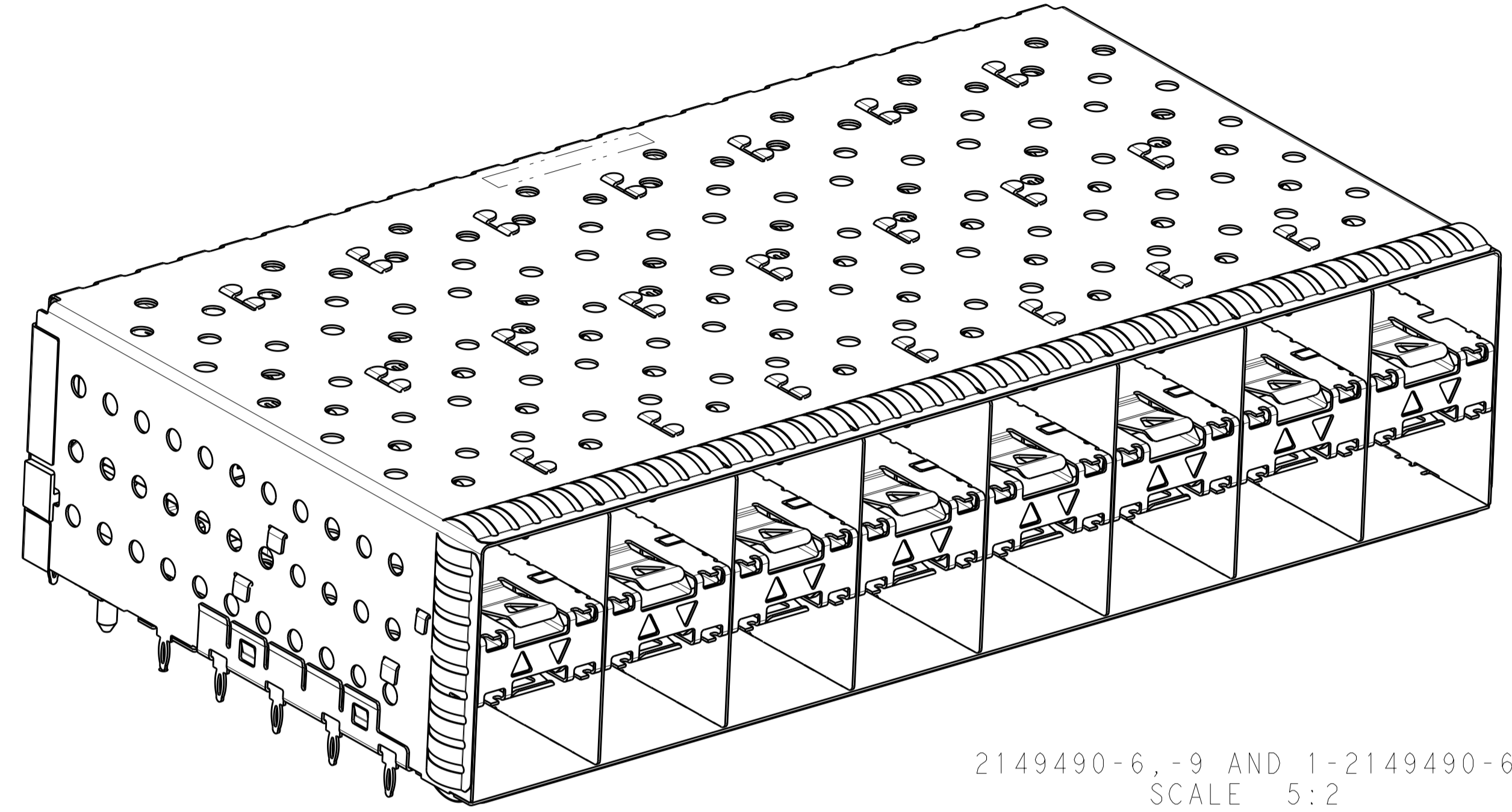

2149490-6, -9 AND 1-2149490-6
 SCALE 5:2

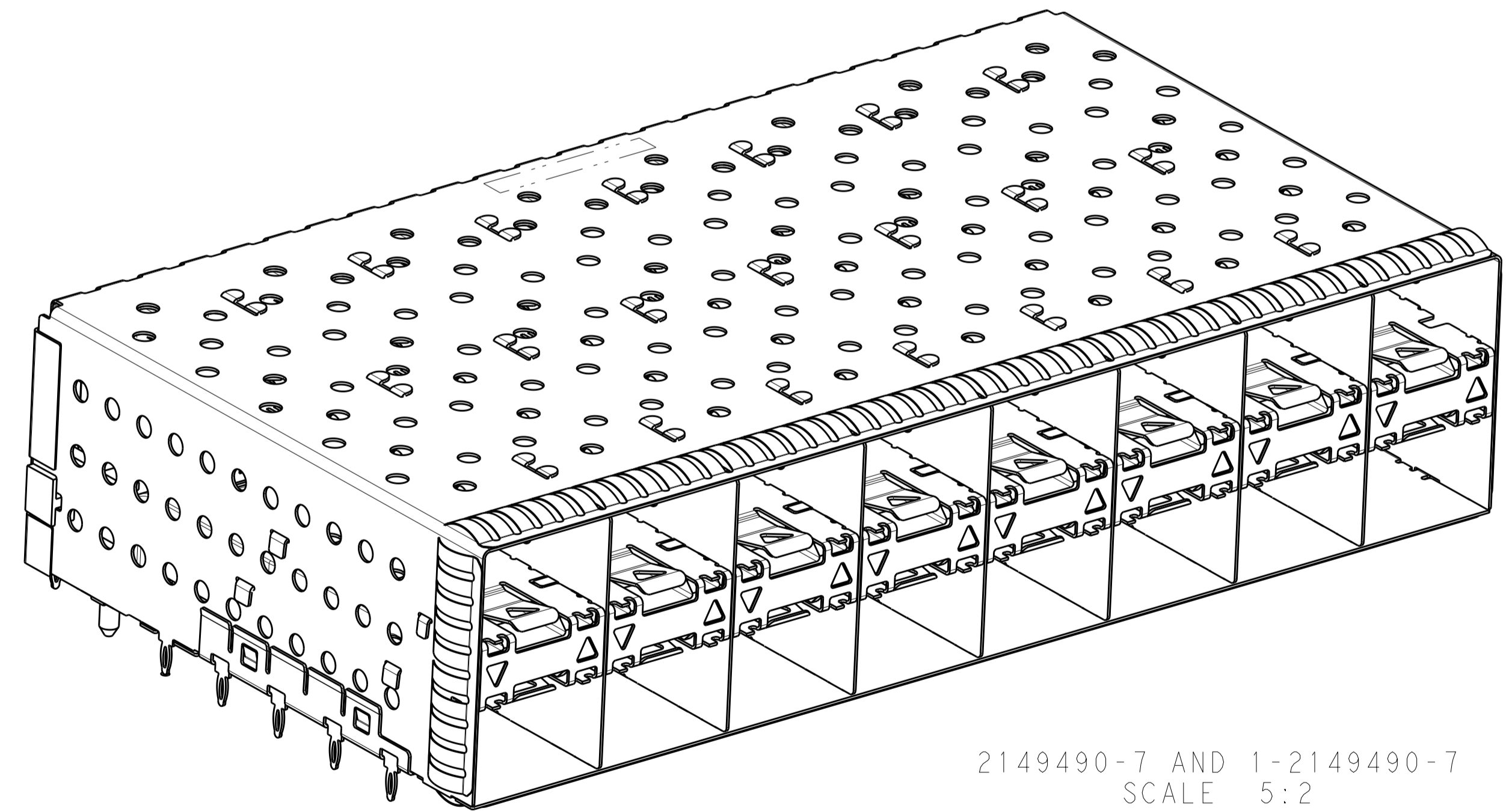

2149490-7 AND 1-2149490-7
 SCALE 5:2

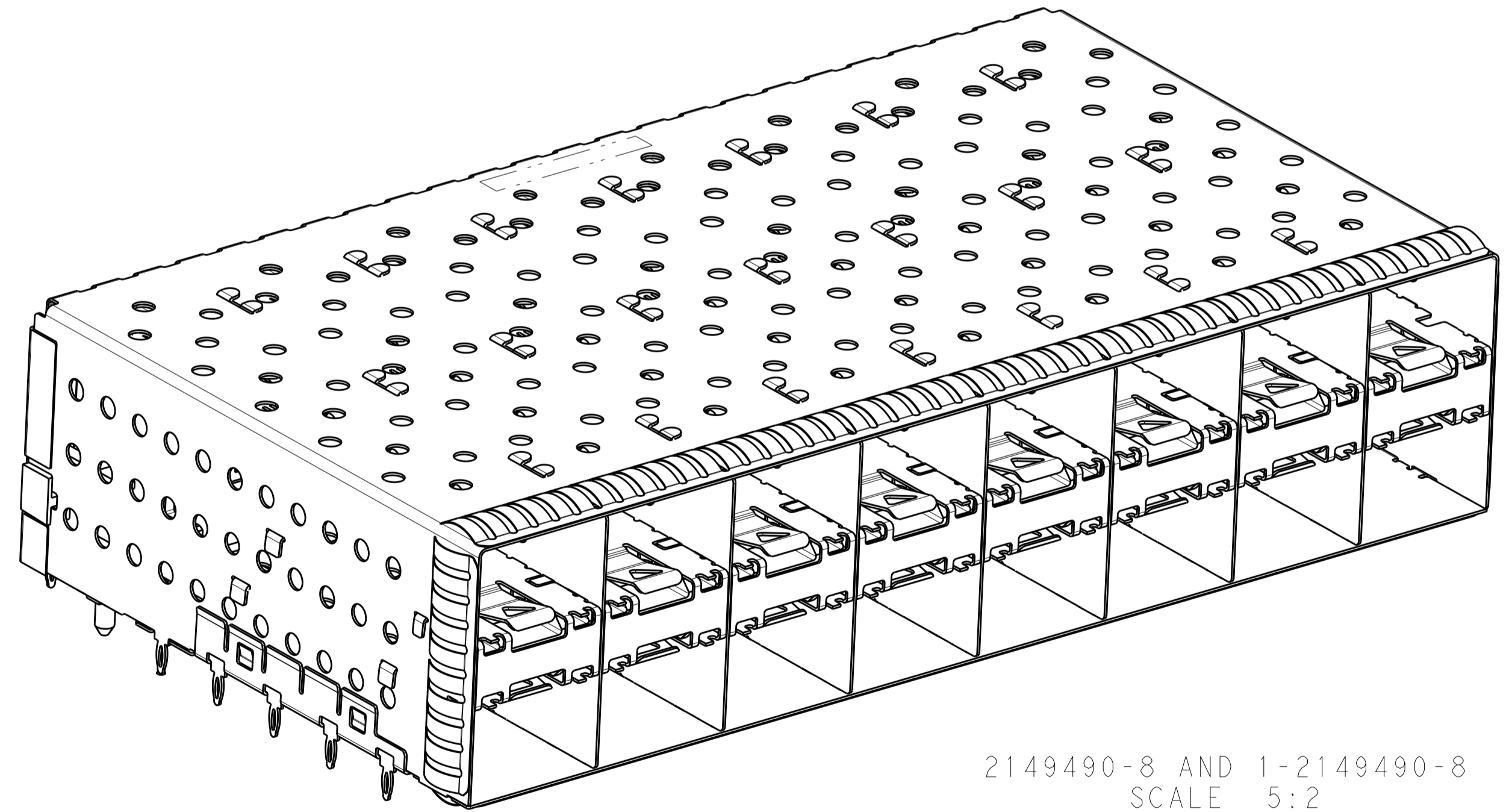

2149490-8 AND 1-2149490-8
 SCALE 5:2

THIS DRAWING IS A CONTROLLED DOCUMENT. DIMENSIONING AND TOLERANCING PER ASME Y14.5M-2009.		DWN C. VALENTINE 08OCT2010	TE Connectivity
DIMENSIONS: mm		CHK J. PETERSON 08OCT2010	
TOLERANCES UNLESS OTHERWISE SPECIFIED:		APVD J. PETERSON 08OCT2010	NAME CAGE AND PT CONNECTOR ASSEMBLY, WITH EMI SPRINGS, PRESS FIT, 2X8, STACKED SFP+
0 PLC	±	PRODUCT SPEC	SIZE 108-2331
1 PLC	±0.10	APPLICATION SPEC	RESTRICTED TO
2 PLC	±0.10	114-13219	A100779C=2149490
3 PLC	±0.10	WEIGHT	SCALE 3:1 SHEET 2 OF 4 REV B1
4 PLC	±0.10	CUSTOMER DRAWING	
ANGLES	±		
MATERIAL	FINISH		

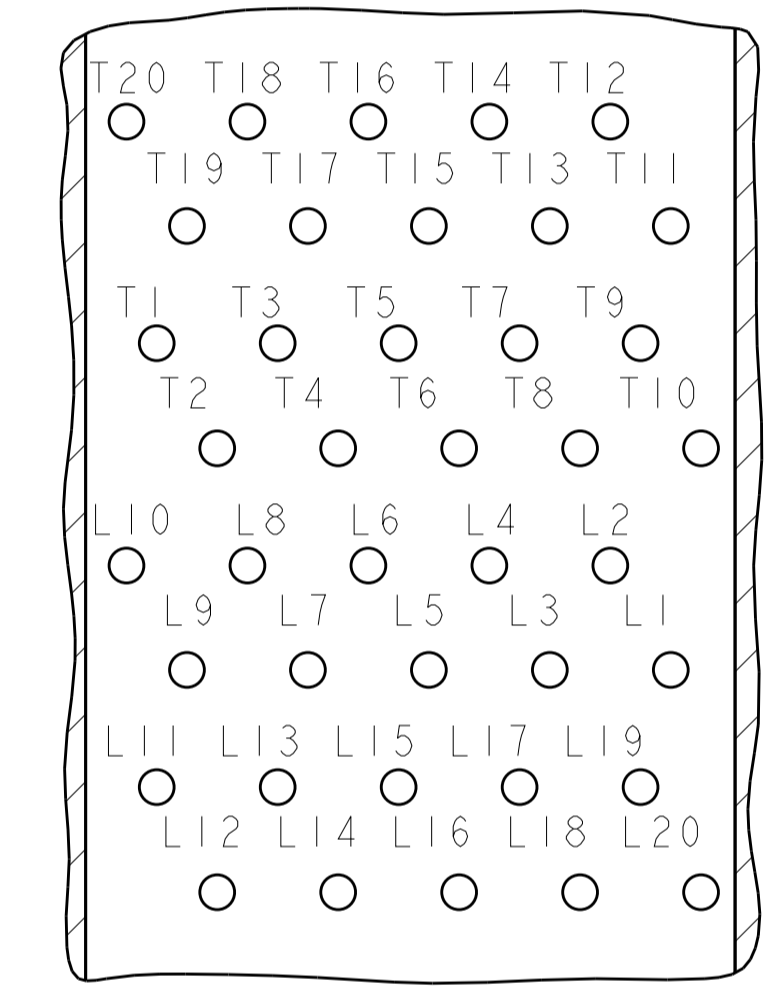
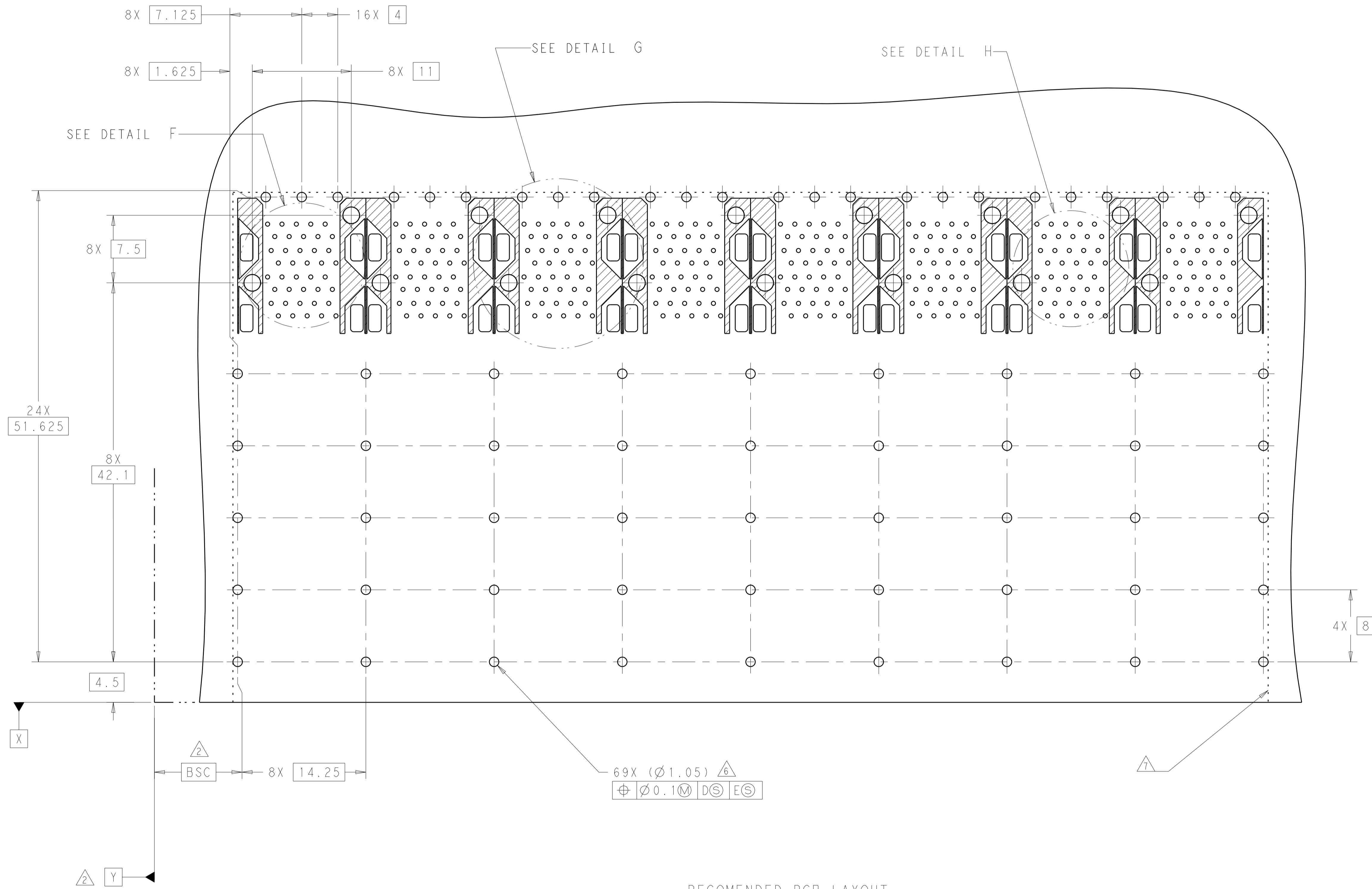

DETAIL H
 CONNECTOR PIN-OUT
 COMPONENT SIDE OF BOARD
 8X INDIVIDUALLY
 SCALE 10:1

RECOMENDED PCB LAYOUT
 COMPONENT SIDE OF THE BOARD
 SCALE 4:1

THIS DRAWING IS A CONTROLLED DOCUMENT. DIMENSIONING AND TOLERANCING PER ASME Y14.5M-2009.		DWN C. VALENTINE 08OCT2010	TE Connectivity
DIMENSIONS: mm		CHK J. PETERSON 08OCT2010	
TOLERANCES UNLESS OTHERWISE SPECIFIED: 0 PLC ±.10 1 PLC ±0.10 2 PLC ±0.10 3 PLC ±0.10 4 PLC ±0.10 ANGLES ±.10 FINISH		APVD J. PETERSON 08OCT2010	NAME CAGE AND PT CONNECTOR ASSEMBLY, WITH EMI SPRINGS, PRESS FIT, 2X8, STACKED SFP+
MATERIAL		PRODUCT SPEC 108-2331	SIZE A100779C=2149490
		APPLICATION SPEC 114-13219	RESTRICTED TO
		WEIGHT	SCALE 3:1 SHEET 3 OF 4 REV B1
		CUSTOMER DRAWING	