

THIS DRAWING IS UNPUBLISHED. RELEASED FOR PUBLICATION 20  
 © COPYRIGHT 20 BY - ALL RIGHTS RESERVED.

LOC		DIST		REVISIONS			
P	LTR	DESCRIPTION	DATE	DWN	APVD		
	A	REVISED PER ECR-15-010341	24JUL2015	RS	PO		
	A1	REVISED PER ECR-15-011381	05AUG2015	RS	JL		
	B	REVISED PER ECR-17-008257	12JUN2017	SK	JL		

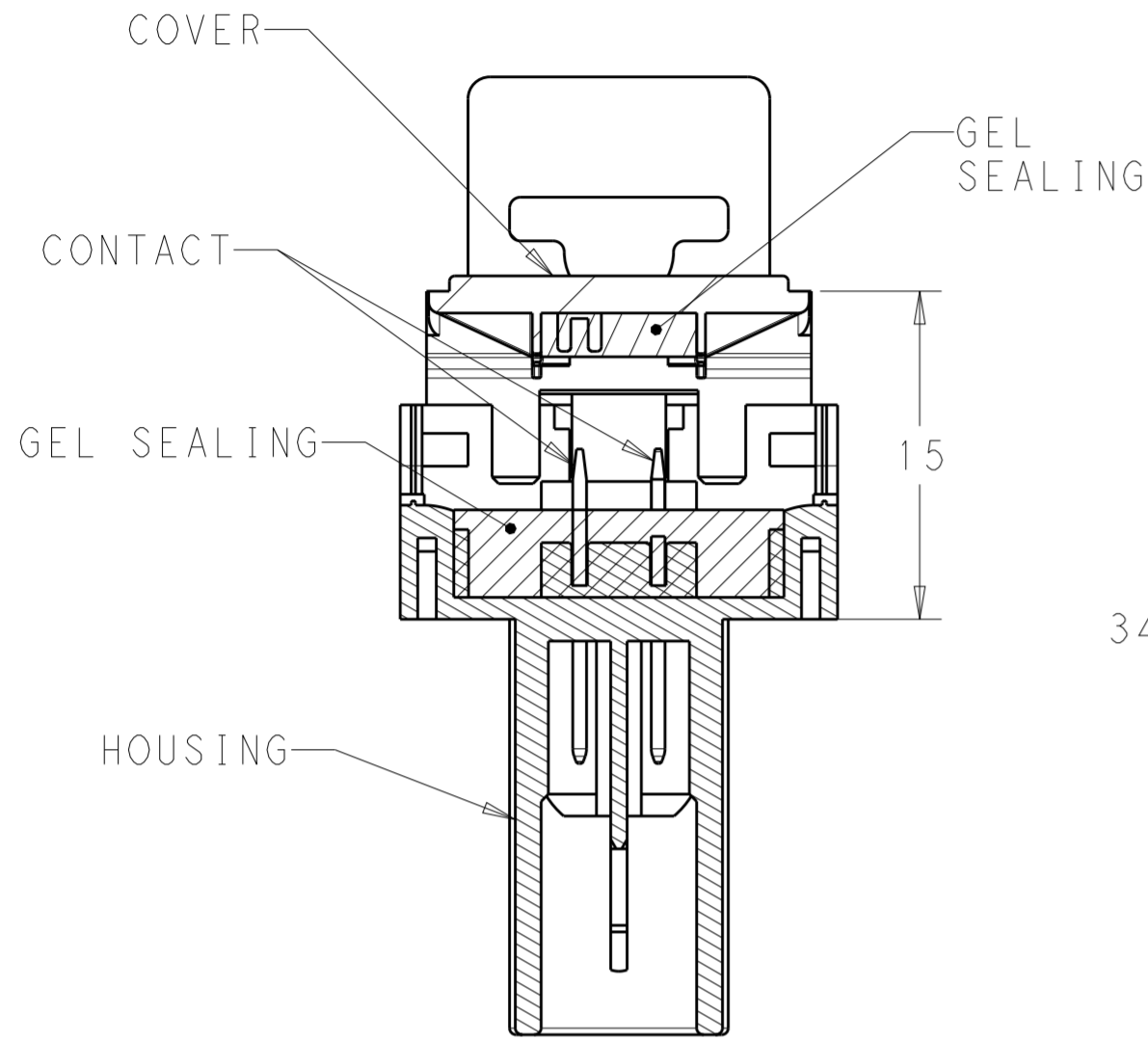

SECTION A-A

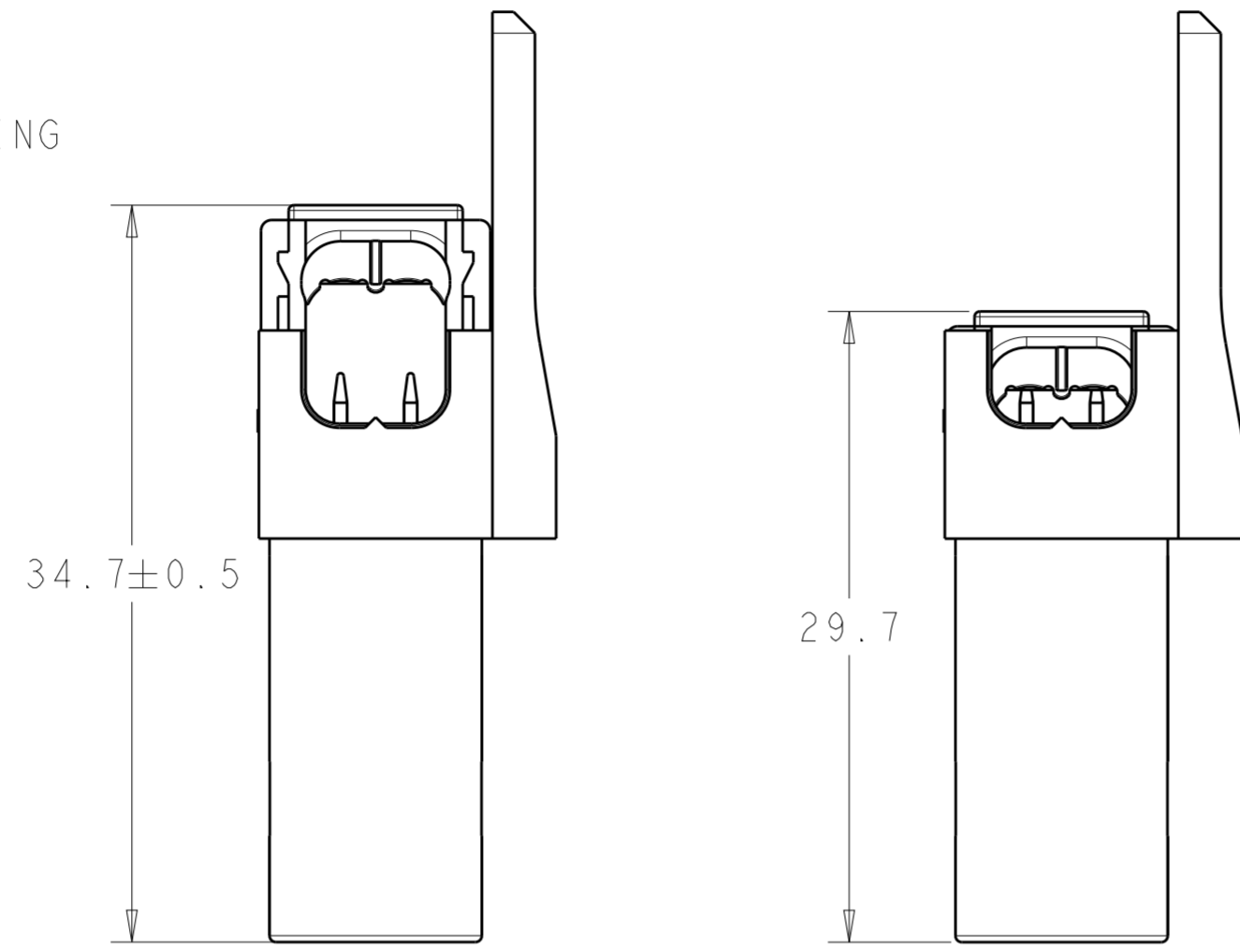

PRE-LOCKING CONDITION

CLOSED CONDITION

1. MATERIAL AND FINISH:  
 HOUSING AND CAP: PBT+PC, COLOR: NATURAL  
 CONTACTS: COPPER ALLOY, FINISH: TIN OVER NICKEL  
 SEALING GEL: SILICONE DIELECTRIC GEL
2. MUST COMPLY WITH DIRECTIVE 2002/95/EC (ROHS)
3. TO BE USED WITH UL SPT-2, 2/C 18 AWG TYPE WIRE

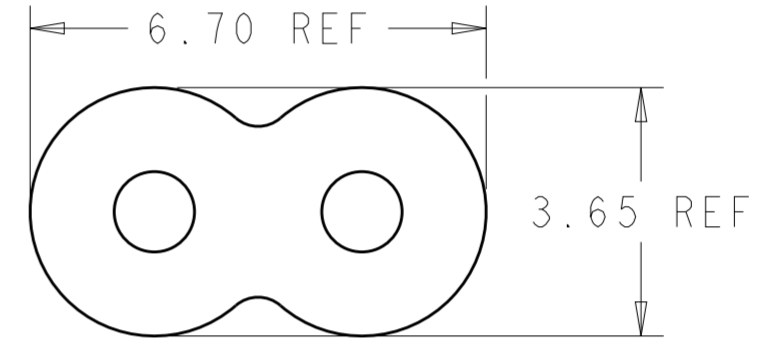

TYPICAL SPT-2 CABLE

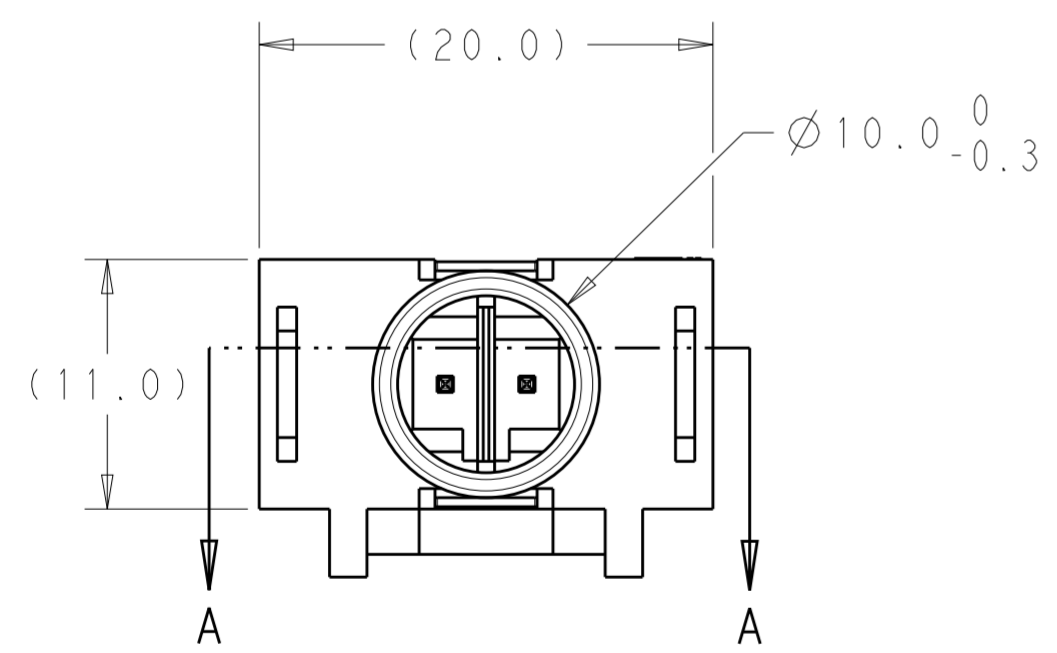

TYPICAL VIEW  
 SEE PAGE 3 FOR  
 ALL VARIATIONS

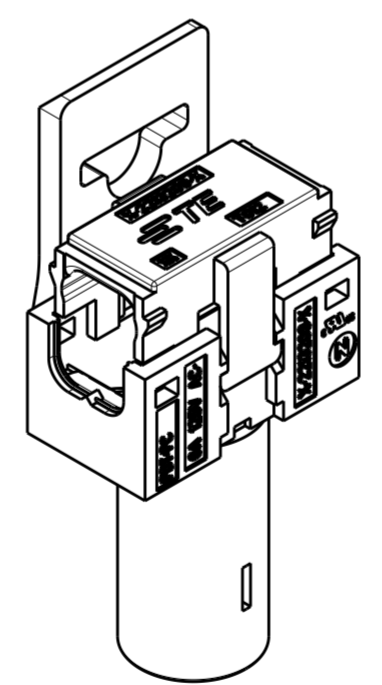

NO	LV-2	END HOUSING, WITHOUT TAB	7-2213222-4	
NO	HV-3	END HOUSING, WITHOUT TAB	7-2213222-1	
NO	LV-2	END HOUSING, WITH TAB	6-2213222-4	
NO	HV-3	END HOUSING, WITH TAB	6-2213222-1	
NO	LV-2	THRU HOUSING, WITHOUT TAB	5-2213222-4	
NO	HV-3	THRU HOUSING, WITHOUT TAB	5-2213222-1	
NO	LV-2	THRU HOUSING, WITH TAB	4-2213222-4	
NO	HV-3	THRU HOUSING, WITH TAB	4-2213222-1	
YES	LV-2	END HOUSING, WITHOUT TAB	3-2213222-4	
YES	HV-3	END HOUSING, WITHOUT TAB	3-2213222-1	
YES	LV-2	END HOUSING, WITH TAB	2-2213222-4	
YES	HV-3	END HOUSING, WITH TAB	2-2213222-1	
YES	LV-2	THRU HOUSING, WITHOUT TAB	1-2213222-4	
YES	HV-3	THRU HOUSING, WITHOUT TAB	1-2213222-1	
YES	LV-2	THRU HOUSING, WITH TAB	2213222-4	
YES	HV-3	THRU HOUSING, WITH TAB	2213222-1	
SEALING GEL		POLARIZATION KEY	HOUSING TYPE	PART NO.

THIS DRAWING IS A CONTROLLED DOCUMENT.

DIMENSIONS: mm	TOLERANCES UNLESS OTHERWISE SPECIFIED: 0 PLC ±0.5 1 PLC ±0.15 2 PLC ±0.1 3 PLC ± 4 PLC ± ANGLES ±1 FINISH	DWN RAVLS 18MAR2013 CHK C. GINGRICH 18MAR2013 APVD C. GINGRICH 18MAR2013	TE Connectivity ASSEMBLY: NECTOR S BUS BAR NA	
MATERIAL		PRODUCT SPEC 108-20294 APPLICATION SPEC 114-20131 WEIGHT -	SIZE A2 CAGE CODE 00779 DRAWING NO C-2213222	RESTRICTED TO -
Customer Drawing		SCALE 2	SHEET 1 OF 3	REV B

THIS DRAWING IS UNPUBLISHED. RELEASED FOR PUBLICATION 20  
 © COPYRIGHT 20 BY - ALL RIGHTS RESERVED.

LOC	DIST	REVISIONS			
P	LTR	DESCRIPTION	DATE	DWN	APVD
-	-	SEE SHEET 1	-	-	-

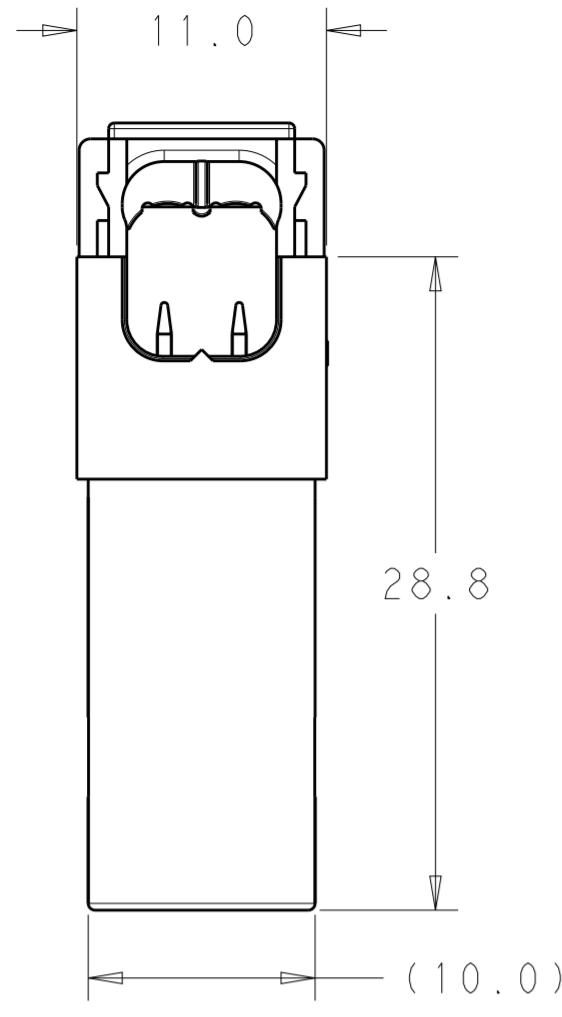

HOUSING WITHOUT TAB

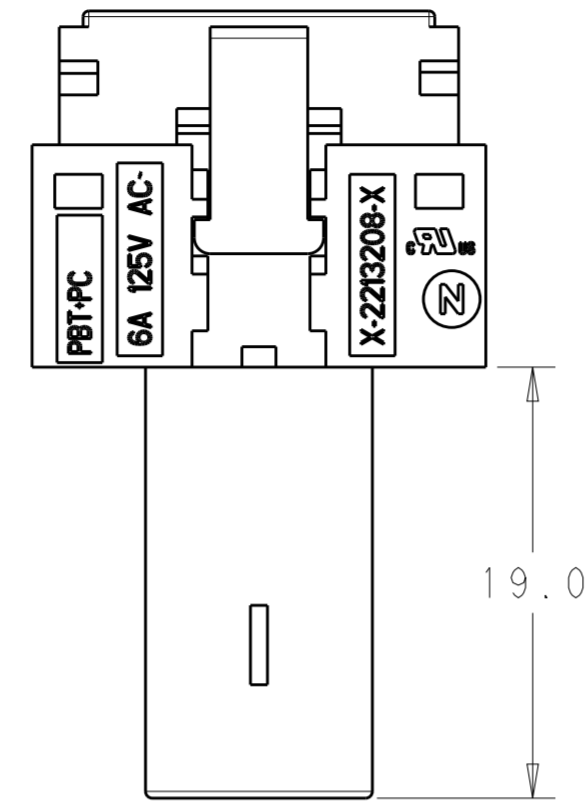

19.0

END HOUSING WITH TAB

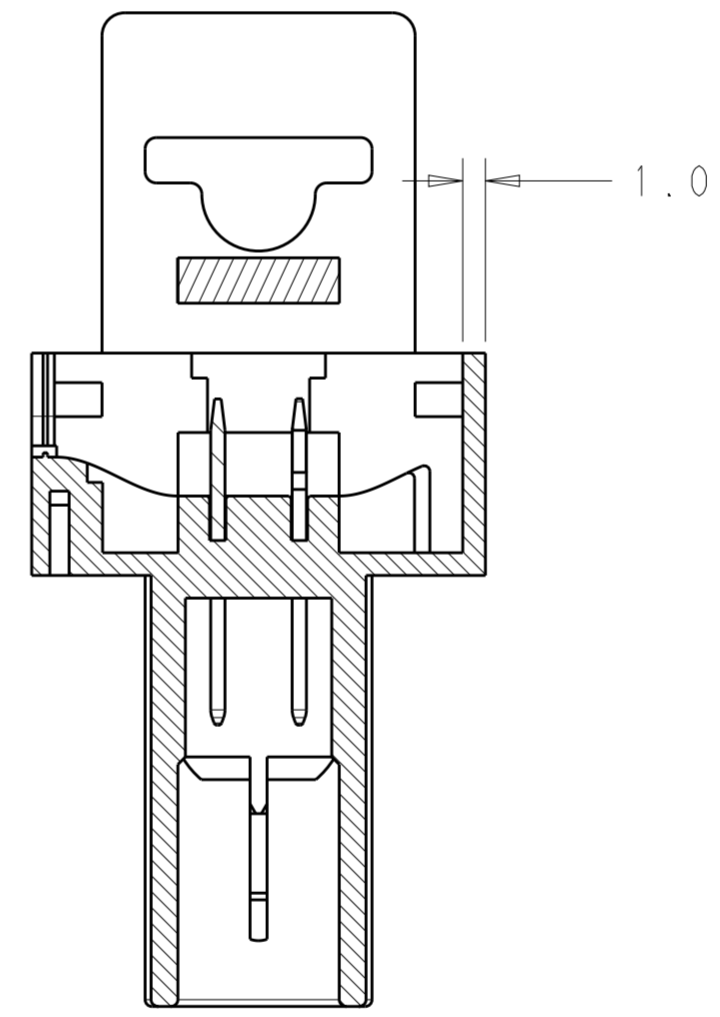
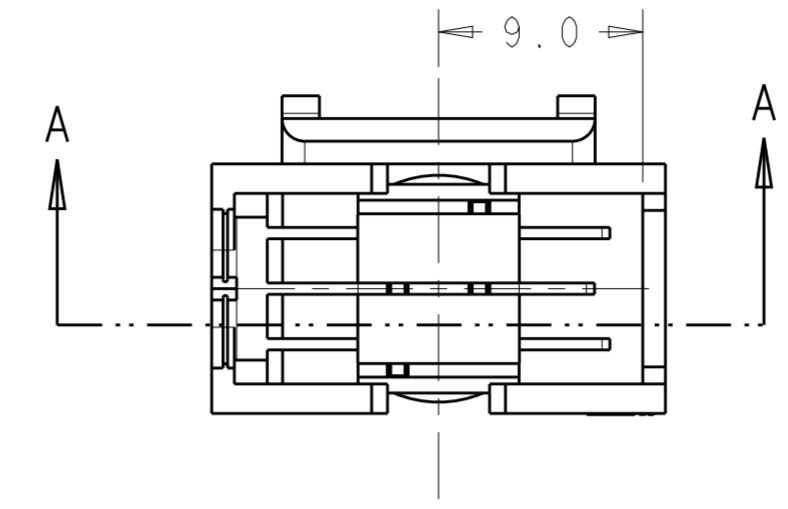

SECTION A-A  
SCALE 3:1

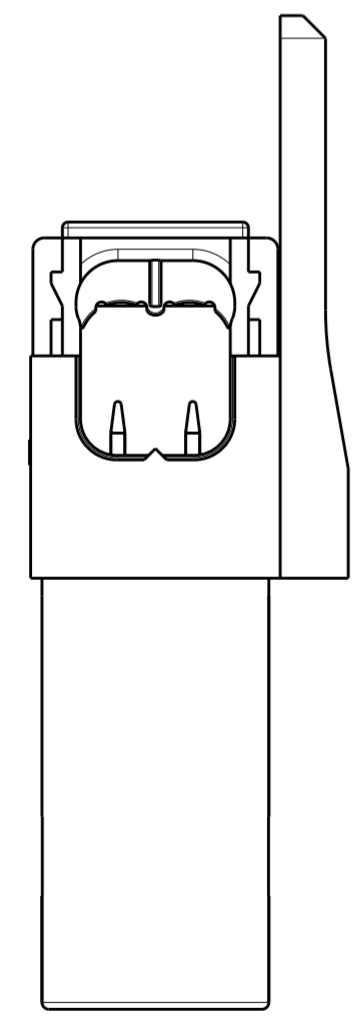

HOUSING WITH TAB

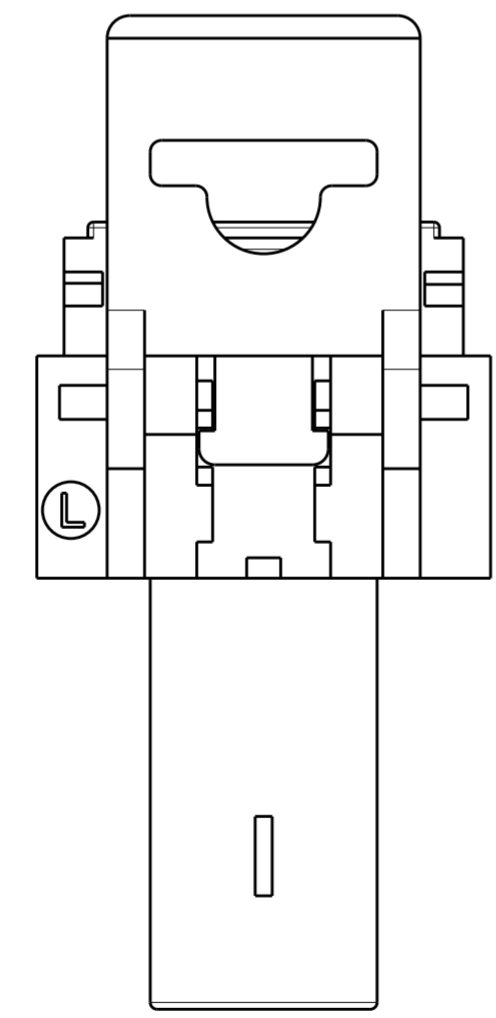

THIS DRAWING IS A CONTROLLED DOCUMENT.		DWN RAVI.S 18MAR2013	TE Connectivity	
DIMENSIONS:		CHK C. GINGRICH 18MAR2013		
mm	TOLERANCES UNLESS OTHERWISE SPECIFIED:	APVD C. GINGRICH 18MAR2013	NAME ASSEMBLY: NECTOR S BUS BAR NA	
0 PLC ±0.5	1 PLC ±0.15	PRODUCT SPEC 108-20294	SIZE	RESTRICTED TO
2 PLC ±0.1	3 PLC ±	APPLICATION SPEC 114-20131	CAGE CODE A200779	DRAWING NO C-2213222
4 PLC ±	ANGLES ±1	WEIGHT	SCALE	SHEET
MATERIAL	FINISH	Customer Drawing	2	2 OF 3
				REV B