

P	LTR	DESCRIPTION	DATE	DWN	APVD
2		INFORMATION ADDED TO SHEET 2	01OCT2020	SM	MZ
3		DRAFTING UPDATE	29OCT2020	SM	MZ
A		PRODUCT UNDER TESTING	24NOV2020	SM	MZ
AI		18AWG WIRE SIZE ADDED	27JAN2022	DM	SM

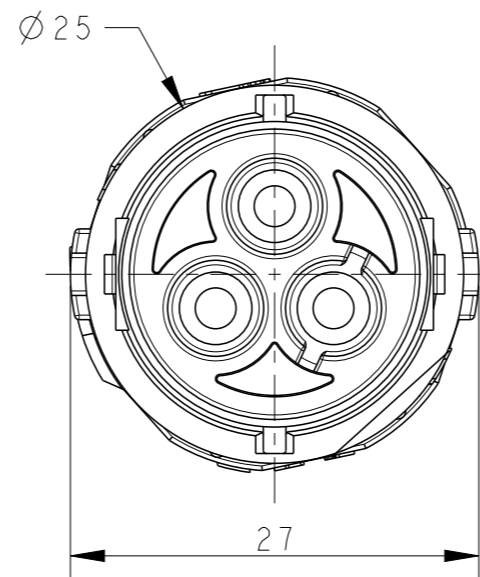
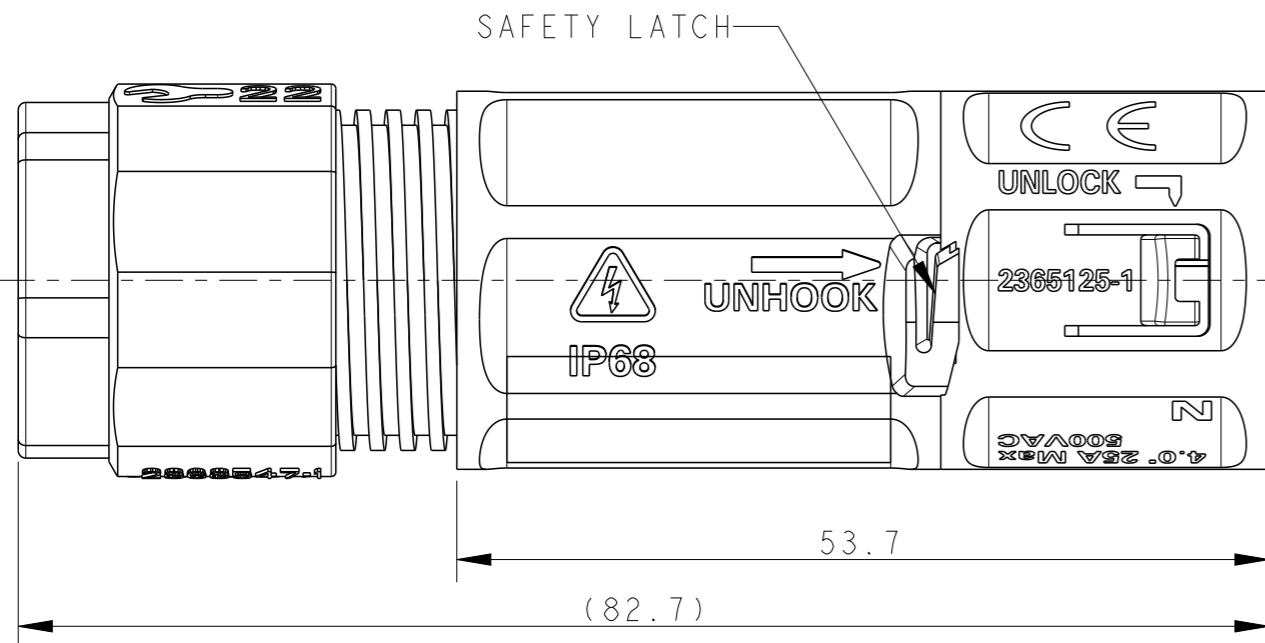

NOTES:

CONTACTS SUPPLIED SEPARATELY ON REELS, MUST PURCHASED ACCORDING TO WIRE SIZES. BELOW ARE THE CONTACT PART NUMBERS:

CONTACT P/N	WIRE SIZE
2359527-1	1.5mm ² TO 2.5mm ² 16AWG TO 14AWG
2359527-2	4.0mm ² 12AWG
2359527-3	18AWG

PRODUCT UNDER TESTING
CONTACT PRODUCT ENGINEERING BEFORE USING THIS PRINT

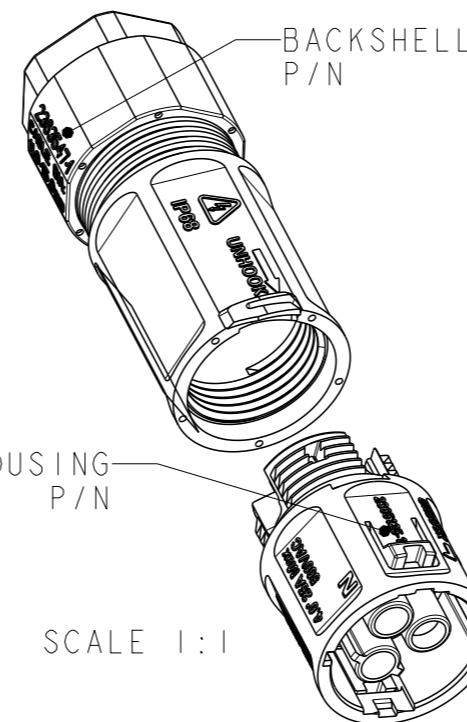

- MATERIALS:
PLASTICS: PBT+PC ALLOY, UL-V0, UV-FI
CONTACTS: COPPER ALLOY, TIN PLATED
SCREWS : STAINLESS STEEL
- OPERATING RATINGS :
VOLTAGE (max): 600Vac Max
CURRENT (max): 25A ON 4.0mm² & 20A ON 12AWG
TEMPERATURE : -40°C TO 85°C
IP RATING : IP67 & IP68
- FOR ASSEMBLY INSTRUCTIONS, REFER APPLICATION SPECIFICATION 114-133123
- PACKAGING: MOQ 200 pcs IN PE BAG

POLARIZING KEY A
2379239-1
1-2379239-1

POLARIZING KEY B
2379239-2
1-2379239-2

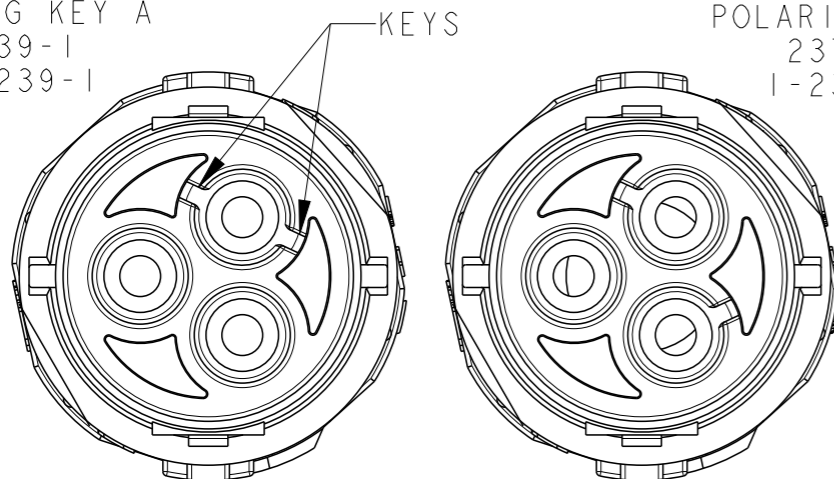

BACKSHELL FOR
2379239-1
2379239-2

BACKSHELL FOR
1-2379239-1
1-2379239-2

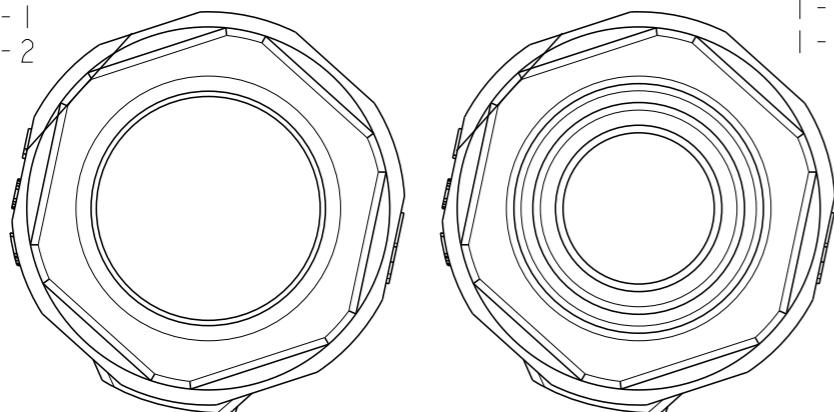

BACKSHELL P/N	HOUSING ASSY P/N	POLARIZING KEY	CABLE RANGE	DESCRIPTION	PART NUMBER
2363547-2	2365125-2	KEY B	Ø7 - Ø10	IN-LINE SOCKET CONNECTOR	1-2379239-2
	2365125-1	KEY A			1-2379239-1
2363547-1	2365125-2	KEY B	Ø10.5 - Ø15		2379239-2
	2365125-1	KEY A			2379239-1

THIS DRAWING IS A CONTROLLED DOCUMENT.

DWN	SUBHASH. M	28AUG2020	 TE Connectivity	NAME NECTOR T, 3Pos, SOCKET CONNECTOR CRIMP TYPE		
CHK	M. ZUCCA	28AUG2020				
APVD	PETER OTT	24NOV2020				
PRODUCT SPEC	-	-				
APPLICATION SPEC	-	-	SIZE	CAGE CODE	DRAWING NO	RESTRICTED TO
MATERIAL	-	-	A300779	C-2379239	-	-
MATERIAL	-	-	CUSTOMER DRAWING	SCALE	SHEET	REV
			2:1	1 OF 2	AI	

DIMENSIONS:	TOLERANCES UNLESS OTHERWISE SPECIFIED:
mm	
0 PLC	±0.2
1 PLC	±0.2
2 PLC	±0.1
3 PLC	±
4 PLC	±
ANGLES	±1°
FINISH	-
	-

REVISIONS

P	LTR	DESCRIPTION	DATE	DWN	APVD
-	-	SEE SHEET 1	-	-	-

CRIMP TERMINATION
 REFER 114-133123 FOR DETAILED INSTRUCTION
 NOT TO SCALE

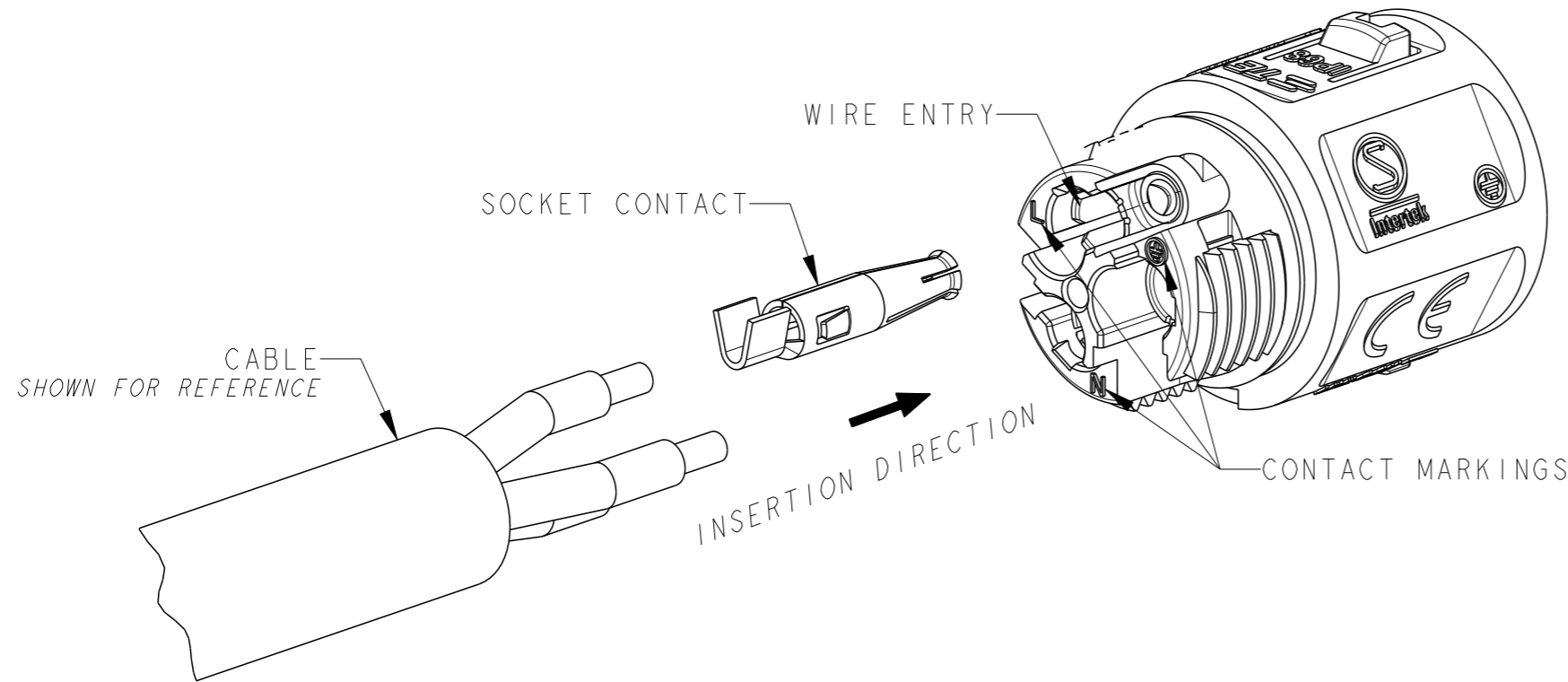

EXPLODED COMPONENTS
 NOT TO SCALE

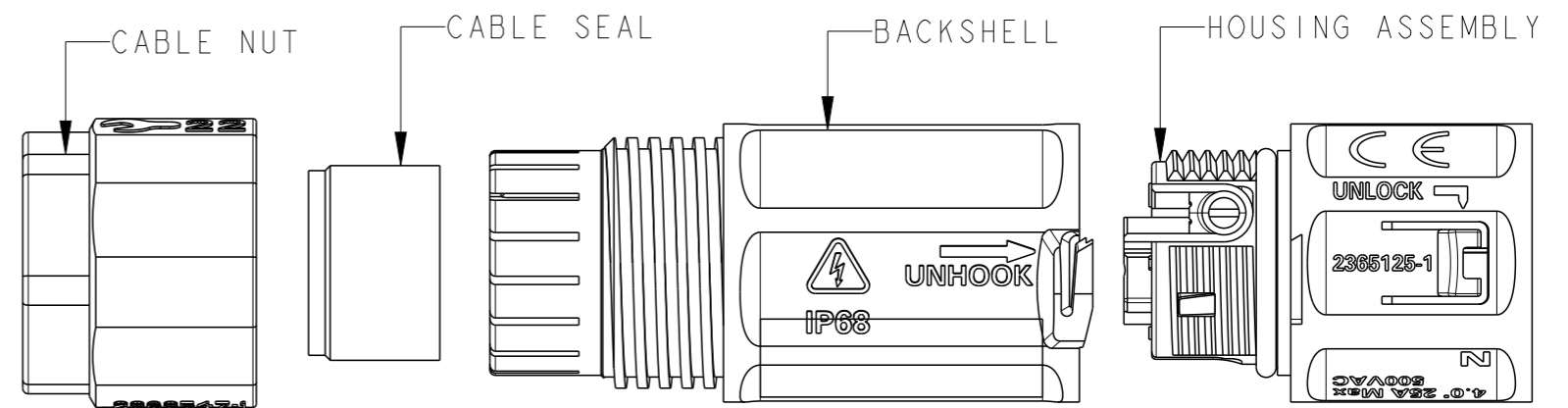

THIS DRAWING IS A CONTROLLED DOCUMENT.		DWN SUBHASH. M 28AUG2020	TE Connectivity	
DIMENSIONS: mm		CHK M. ZUCCA 28AUG2020		
TOLERANCES UNLESS OTHERWISE SPECIFIED:		APVD PETER OTT 24NOV2020	NAME NECTOR T, 3Pos, SOCKET CONNECTOR CRIMP TYPE	
0 PLC ±0.2 1 PLC ±0.2 2 PLC ±0.1 3 PLC ± 4 PLC ± ANGLES ±1°		PRODUCT SPEC -	SIZE A3	CAGE CODE 00779
MATERIAL -	FINISH -	APPLICATION SPEC -	DRAWING NO C-2379239	RESTRICTED TO -
CUSTOMER DRAWING		WEIGHT -	SCALE 2:1	SHEET 2 OF 2
				REV A1