

Features

- Dual Action (Rate of Rise/Fixed Temperature) or Fixed Temperature only.
- Available with protective light hazard guard (specify “MPG” when ordering).
- Up to 70’ inter detector spacing.
- Secure fusible link mechanism locks contacts in alarm state when releasing temperature is reached.
- Operating temperature range -40°F/+250°F (-40°C/120°C).
- Fly leads are factory installed and sealed in corrosion resistant mounting plate.



7270-1110:0100



S2406



Description

The MP Series is a standard THERMOFLEX® single circuit, Normally Open contacts detectors, in which the connectivity is modified with pigtail leads that extend through a seal plate. This provides for enhanced protection against corrosive or moisture-laden environments.

This detector is suitable for use in areas where condensation or corrosion can have harmful effects on circuit wiring connected to standard terminals. Its seal plate (with extended pigtail leads) will mount onto a typical cast exterior back box. The detector is connected to a fire alarm system’s input circuit as an initiating device. The internal contacts are normally open, and will close when the detector operates either on a rate of temperature increase, or if the releasing temperature is reached. It is often installed with an addressing module if it is to be annunciated as a specific room or space, e.g. electrical room, garbage compactor, etc. With its non-metallic diaphragm, the detector can operate normally at low temperatures, making it suitable for non-heated or chilled environments including garages and carports.

Technical Specifications

Dimensions	4.375" (11.11 cm) x 2.0" (5.08 cm)
Device Weight	.41 lbs (.19 grams)
Contact Ratings	3 Amps at 125VAC 1 Amp at 28VDC 0.3 Amps at 125VDC 0.1 Amps at 250 VDC
Environmental Limitations	-20°F (-30°C) - 250°F (120°C) Exclusive of Operating Temperature
Mounting	4" Round Standard WP Electrical Box

Models CR-135MP, CR-165MP, CR-165MP, and CR-200MP

These models are dual-action types that will respond to a rate of temperature increase at the ceiling of 15° Fahrenheit degrees per minute (8.4° Celsius degrees per minute). These detectors will also respond when the fixed temperature (non-restorable) threshold is exceeded. Dual-action detectors are installed in areas where rapid fluctuations in ceiling temperatures are not expected.

Models CF-135MP, CF-165MP, CF-200MP, and CF-285MP

These models are fixed temperature only detectors and should be installed in areas where rapid fluctuations in ceiling temperatures are expected.

Installation

On conventional, initiating circuits, or when using an addressing module, contacts are installed across the circuit such that operation of the detector will create a short circuit condition, required in order to activate the fire alarm control panel (FACP), or addressing module.

Fig 1

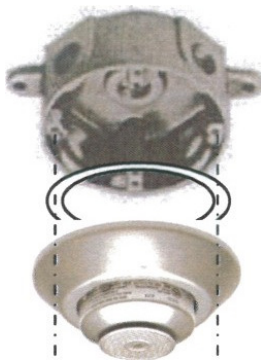
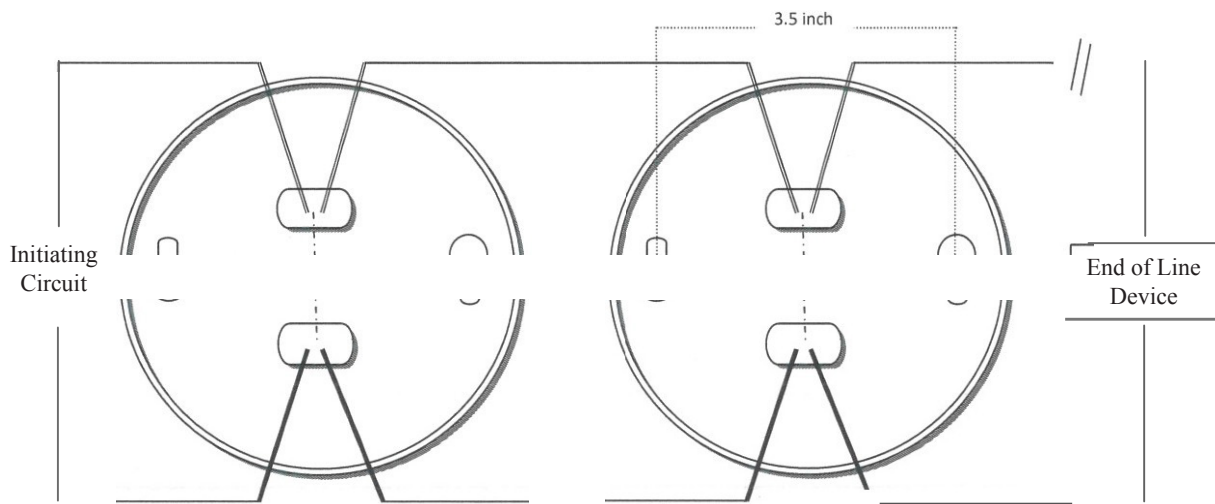

The detector is installed using rain-tight conduit and a standard, approved weatherproof electrical enclosure as shown above. A neoprene (or similar gasket supplied with the back box), is installed between the detector's seal plate and the back box. The wire leads are connected to the initiating circuit inside the enclosure. Unused threaded openings are sealed with threaded plugs. A decorative anodized aluminum cover ring snaps over the detector to complete the installation.