

FCI CONFIDENTIAL

PRODUCT NUMBER  
NOTE 3  
10080594-3AD0117LF

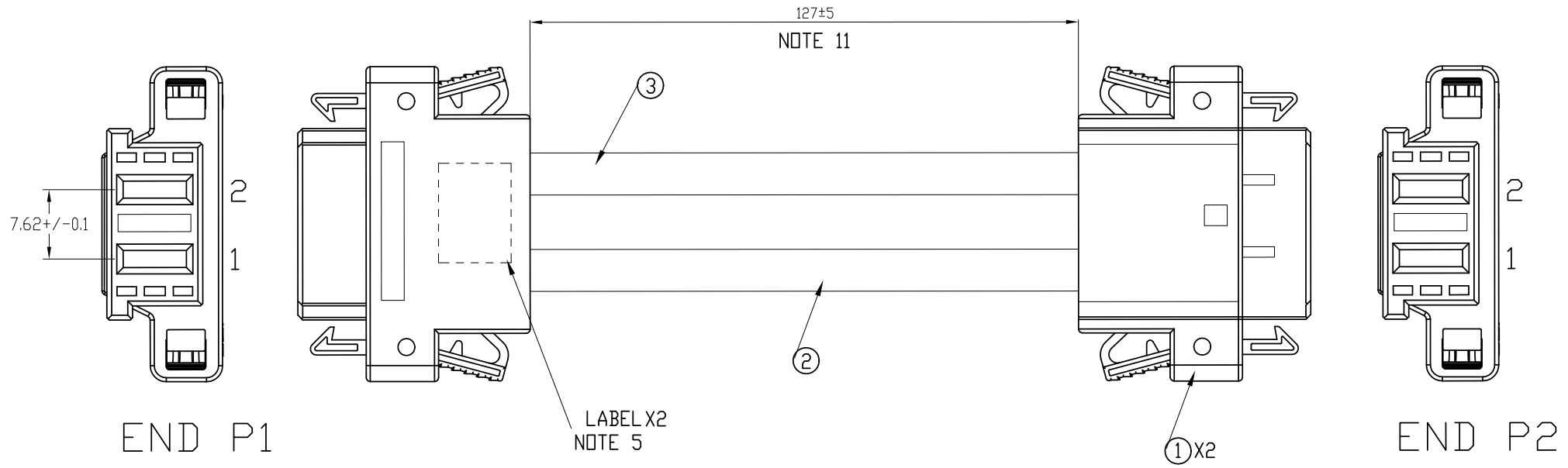

| END P1 | WIRE       | END P2 |
|--------|------------|--------|
| 1      | 8AWG BLACK | 1      |
| 2      | 8AWG RED   | 2      |

| Qty | Unit | Description                       | Item |
|-----|------|-----------------------------------|------|
| NA  | M    | UL10198 ULTRA FLEXIBLE 8AWG RED   | 3    |
| NA  | M    | UL10198 ULTRA FLEXIBLE 8AWG BLACK | 2    |
| 2   | PC   | Housing 2Acp KIT 0.30" spacing    | 1    |

|             |    |    |                       |                               |                 |                                       |   |
|-------------|----|----|-----------------------|-------------------------------|-----------------|---------------------------------------|---|
| mat'l. code |    |    | surface<br>ISO 1302 ✓ | tolerance<br>ISO 406 ISO 1101 | projection<br>⊕ | product family<br>Power blade         |   |
| l           | tr | ec | no                    | dr                            | date            | tolerances unless otherwise specified |   |
| c           | -  |    |                       | wilson                        | 01-12'12        | angles                                | linear                                  |
|             |    |    |                       |                               |                 | linear                                | MM                                      |
|             |    |    |                       |                               |                 | scale 4                               | title<br>PowerBlade 2Acp Cable Assembly |
|             |    |    |                       | dr                            | wilson          | 10-06'09                              | product no                              |
|             |    |    |                       | enr                           | wilson          | 10-06'09                              | sheet 1 of 2                            |
|             |    |    |                       | chr                           | wilson          | 10-06'09                              | size                                    |
|             |    |    |                       | app                           | Jackson         | 10-06'09                              | 10080594-3AD0117LF                      |
|             |    |    |                       |                               |                 |                                       | A3                                      |
|             |    |    |                       |                               |                 |                                       | Type Customer Drawing                   |

FCI  
FCIconnect.com  
Copyright FCI

This document may be used in any way or disclosed to others without the written consent of FCI.

NOTES:

①. END P1 MATES WITH FCI HEADER P/N 51939-475LF or 51963-046LF.  
END P2 MATES WITH FCI HEADER P/N 51939-475LF or 51963-046LF.

②. UNLESS OTHERWISE SPECIFIED ASSEMBLED LENGTH TOLERANCE =  
< 1 METER: ±15.0mm  
> 1 METER TO 10 METER: ±2% OF L1  
> 10 METER: +0.00% / -4% OF L1

3. PART NUMBER DESCRIPTION:

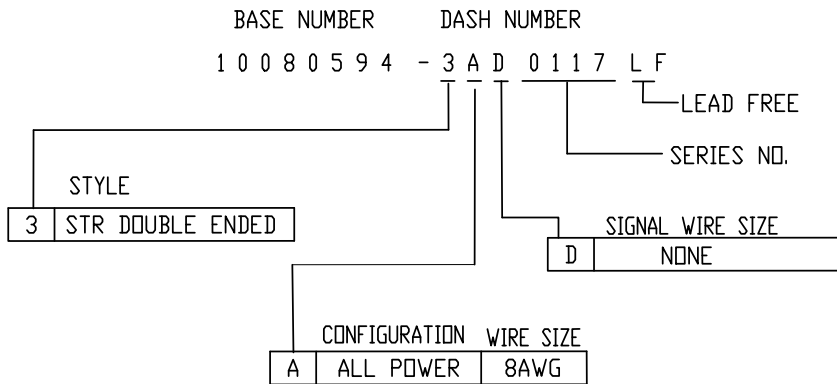

4. UNLESS OTHERWISE SPECIFIED LABEL POSITION SHALL BE APPROXIMATELY 50mm FROM REAR OF CONNECTOR.

⑤. LABEL OR INK STAMP 660-0218 ASSEMBLY NUMBER, REVISION, MFG. DATE CODE, AND SUPPLIER I.D. WITH .10" HIGH CHARACTERS APPROXIMATELY WHERE INDICATED. MARK TO 660 LEVEL PER PURCHASE ORDER OR CURRENT BILL OF MATERIAL.

RPM1191529/1 R1D  
WWYY FCI

⑥. ALL CABLE ASSEMBLIES SHALL BE TESTED 100% FOR CONTINUITY AS DEFINED IN WIRING LIST.

7. UNLESS OTHERWISE SPECIFIED ALL CABLE ASSEMBLIES SHALL BE 100% HI-POT TESTED BY APPLYING 300V DC FOR MINIMUM OF 10ms, UNLESS ACTIVE COMPONENTS ARE USED IN THIS ASSEMBLY.

8. ALL CUSTOMER DRAWINGS ARE SUPPLIED WITH METRIC DIMENSIONS.

⑨. LEAD FREE PRODUCTS MEET EUROPEAN UNION DIRECTIVES AND OTHER COUNTRY REGULATIONS AS DESCRIBED IN GS-22-008.

PACKAGING OF LEAD FREE PRODUCTS MEETS LABELING AND PACKAGING SPECIFICATION GS-14-920.

⑩. CONNECTOR ASSEMBLIES SHOWN ARE FOR REFERENCE ONLY AND MAY NOT SHOW ALL PART DETAIL. REFERENCE CONNECTOR HOUSING DRAWINGS FOR COMPLETE DETAILS.

11. BAG AND TAG WITH THE PART NUMBER AND THE LATEST REVISION.

⑫. THIS DIMENSION IS A FINISHED PRODUCT LENGTH.

13. CABLE: UL APPROVED, TEMPERATURE RATING 105°C. 300V .  
HOUSING: HIGH TEMP. THERMOPLASTIC, UL94V-0 GLASS FILLED,  
COLOR: BLACK  
POWER CONTACTS: COPPER ALLOY

|             |  |                       |  |                               |  |                                       |  |                                |  |
|-------------|--|-----------------------|--|-------------------------------|--|---------------------------------------|--|--------------------------------|--|
| mat'l. code |  | surface<br>ISO 1302 ✓ |  | tolerance<br>ISO 406 ISO 1101 |  | projection<br>MM                      |  | product family<br>Power blade  |  |
| l/tecn no   |  | dr                    |  | date                          |  | tolerances unless otherwise specified |  | title                          |  |
| C           |  |                       |  |                               |  | linear                                |  | PowerBlade 2Acp Cable Assembly |  |
|             |  |                       |  |                               |  |                                       |  | scale 4                        |  |
|             |  | dr                    |  | wilson                        |  | 10-06'09                              |  | dwg no                         |  |
|             |  | enr                   |  | wilson                        |  | 10-06'09                              |  | sheet 2 of 2                   |  |
|             |  | chr                   |  | wilson                        |  | 10-06'09                              |  | 10080594-3AD0117LF             |  |
|             |  | appd                  |  | Jackson                       |  | 10-06'09                              |  | A3                             |  |
| sheet       |  | revision              |  | C                             |  |                                       |  | Type Customer Drawing          |  |
| index       |  | sheet                 |  | 2                             |  |                                       |  |                                |  |