

FCI  
FCIconnect.com

END "A" POSITION NO.	WIRE COLOR	END "B" POSITION NO.
P1	BLACK	P1
P2	BLUE	P2

FCI P/N:	DIMENSION 'L1"
10080594-3JD0285LF	762±10
10080594-3JD0341LF	1016±15

NA	MM	UL2586 2*12awg(BLACK,BLUE),BLACK	3
2	PC	BOOT	2
2	PC	2Acp PWRBLADE KIT	1
Qty	Unit	Description	Item

mat'l. code		surface <input checked="" type="checkbox"/>		tolerance		projection		product family C & A	
ltr	ecn no	dr	date	tolerances unless otherwise specified		title			
B	-	W.W	02-24'12	angles	linear	SEE NOTES	MM	PwrBlade 2Acp CABLE ASSEMBLY	
sheet index		revision B		scale		FCI		dwg no sheet 1 of 2 size	
1		1						10080594-3JD0285LF A3	
								type CUSTOMER	

Copyright FCI

NOTES:

- ① BOTH END "A" AND "B" MATE WITH FCI HEADER PART NUMBER 51939-198LF.
- ② UNLESS OTHERWISE SPECIFIED ASSEMBLED LENGTH TOLERANCE =
  - < = 1 METER: ±15.0mm
  - > 1 METER TO 10 METER: ±2% OF L1
  - > 10 METER: +0.00% / -4% OF L1
- 3. PART NUMBER DESCRIPTION:

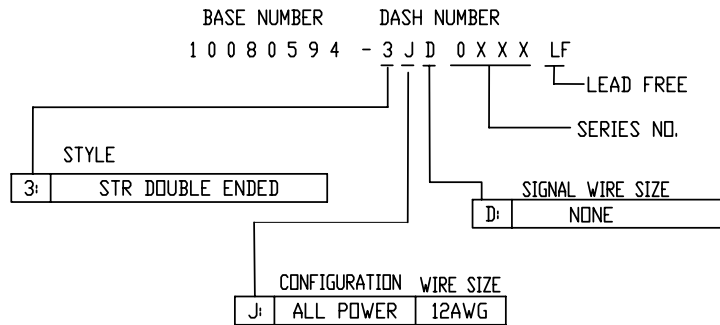

- ④ UNLESS OTHERWISE SPECIFIED LABEL POSITION SHALL BE APPROXIMATELY 50mm FROM REAR OF CONNECTOR.
- ⑤ UNLESS OTHERWISE SPECIFIED STANDARD LABEL SHALL BE BRADY LABEL P/N THT-10-427-3.  
 LABEL DETAILS;
  - MANUFACTURER CODE OR NAME
  - FCI P/N
  - REVISION
  - DATE CODE WW/YY FORMAT
  - COUNTRY ORIGIN
 FONT SHALL BE CLEARLY VISABLE AND BLACK IN COLOR.

- ⑥ ALL CABLE ASSEMBLIES SHALL BE TESTED 100% FOR CONTINUITY AS DEFINED IN WIRING LIST.
- 7. UNLESS OTHERWISE SPECIFIED ALL CABLE ASSEMBLIES SHALL BE 100% HI-POT TESTED BY APPLYING 300V DC FOR MINIMUM OF 10ms, UNLESS ACTIVE COMPONENTS ARE USED IN THIS ASSEMBLY.
- 8. OTHER TESTING PERFORMED AS REQUIRED BY PRODUCT SPECIFICATION: GS-12-474
- 9. ALL CUSTOMER DRAWINGS ARE SUPPLIED WITH METRIC DIMENSIONS.
- ⑩ LEAD FREE PRODUCTS MEET EUROPEAN UNION DIRECTIVES AND OTHER COUNTRY REGULATIONS AS DESCRIBED IN GS-22-008.  
 PACKAGING OF LEAD FREE PRODUCTS MEETS LABELING AND PACKAGING SPECIFICATION GS-14-920.
- ⑪ CONNECTOR ASSEMBLIES SHOWN ARE FOR REFERENCE ONLY AND MAY NOT SHOW ALL PART DETAIL. REFERENCE CONNECTOR HOUSING DRAWINGS FOR COMPLETE DETAILS.
- 12. PACKAGING SPECIFICATION: GS-14-1378.
- ⑬ THIS DIMENSION IS A FINISHED PRODUCT LENGTH.
- 14. CABLE: UL APPROVED, TEMPERATURE RATING 105°C. 120V MIN.  
 HOUSING: HIGH TEMP. THERMOPLASTIC, UL94V-0 GLASS FILLED,  
 COLOR: BLACK  
 POWER CONTACTS: COPPER ALLOY

mat'l. code		surface		tolerance		projection		product family C & A	
ltr		ecn no		dr		date		tolerances unless otherwise specified	
B								SEE NOTES	
				angles		linear		MM	
								scale	
				dr		Wilson.W		09-01'11	
				enr		Wilson.W		09-01'11	
				chr		Wilson.W		09-01'11	
				appd		Jackson		09-01'11	
sheet index		revision sheet		B		2		FCI	
								dwg no 10080594-3JD0285LF	
								sheet 2 of 2 size A3	
								type CUSTOMER	