

**Datasheet**

**MM32F031xx**

**32-bit Micro controller based on ARM Cortex M0**

---

**Ver: 1.13\_q**

# Content

<b>1</b>	<b>Introduction</b>	<b>1</b>
1.1	Description . . . . .	1
1.2	Product Features . . . . .	1
<b>2</b>	<b>Specification</b>	<b>3</b>
2.1	Device contrast . . . . .	3
2.2	Summary . . . . .	3
2.2.1	ARM® Cortex™-M0 and SRAM . . . . .	3
2.2.2	Memory . . . . .	4
2.2.3	SRAM . . . . .	4
2.2.4	Clocks and startup . . . . .	4
2.2.5	Nested vectored interrupt controller (NVIC) . . . . .	4
2.2.6	Extended interrupt/event controller (EXTI) . . . . .	4
2.2.7	Boot modes . . . . .	5
2.2.8	Power supply schemes . . . . .	5
2.2.9	Power supply supervisors . . . . .	5
2.2.10	Voltage regulator . . . . .	5
2.2.11	Low-power modes . . . . .	5
2.2.12	Direct memory access controller (DMA) . . . . .	6
2.2.13	Timers and watchdogs . . . . .	6
2.2.14	Universal asynchronous receiver/transmitter (UART) . . . . .	8
2.2.15	I2C interface . . . . .	9
2.2.16	Serial peripheral interface (SPI) . . . . .	9
2.2.17	General-purpose inputs/outputs (GPIO) . . . . .	9
2.2.18	Analog-to-digital converter (ADC) . . . . .	9
2.2.19	Temperature sensor . . . . .	9
2.2.20	Serial single line SWD debug port (SW-DP) . . . . .	9
<b>3</b>	<b>Pin definition</b>	<b>12</b>
<b>4</b>	<b>Memory mapping</b>	<b>21</b>
<b>5</b>	<b>Electrical characteristics</b>	<b>23</b>
5.1	Parameter conditions . . . . .	23
5.1.1	Minimum and maximum values . . . . .	23
5.1.2	Typical values . . . . .	23
5.1.3	Typical curves . . . . .	23
5.1.4	Loading capacitor . . . . .	23
5.1.5	Pin input voltage . . . . .	24
5.1.6	Power supply scheme . . . . .	24
5.1.7	Current consumption measurement . . . . .	24
5.2	Absolute maximum ratings . . . . .	25
5.3	Operating conditions . . . . .	26
5.3.1	General operating conditions . . . . .	26
5.3.2	Operating conditions at power-up/power-down . . . . .	27

5.3.3	Embedded reset and power control block characteristics . . . . .	27
5.3.4	Embedded internal reference voltage . . . . .	28
5.3.5	Supply current characteristics . . . . .	29
5.3.6	External clock source characteristics . . . . .	32
5.3.7	Internal clock source characteristics . . . . .	36
5.3.8	PLL characteristics . . . . .	38
5.3.9	Memory characteristics . . . . .	38
5.3.10	EMC characteristics . . . . .	39
5.3.11	Absolute Maximum (Electrical Sensitivity) . . . . .	40
5.3.12	I/O port characteristics . . . . .	41
5.3.13	NRST pin characteristics . . . . .	45
5.3.14	Timer characteristics . . . . .	46
5.3.15	Communication interfaces . . . . .	47
5.3.16	12-bit ADC characteristics . . . . .	53
5.3.17	Temperature sensor characteristics . . . . .	57
<b>6</b>	<b>Package information</b>	<b>58</b>
6.1	LQFP48 Package information . . . . .	58
6.2	LQFP32 Package information . . . . .	60
6.3	QFN32 Package information . . . . .	62
6.4	QFN20 Package information . . . . .	64
6.5	TSSOP20 Package information . . . . .	66
<b>7</b>	<b>Ordering information</b>	<b>68</b>
<b>8</b>	<b>Revision history</b>	<b>69</b>

## List of Figures

1	Block diagram . . . . .	10
2	Clock tree . . . . .	11
3	LQFP48 packet pinout . . . . .	12
4	LQFP32 packet pinout . . . . .	13
5	QFN32 packet pinout . . . . .	14
6	QFN20 packet pinout . . . . .	14
7	TSSOP20 packet pinout . . . . .	15
8	Pin loading conditions . . . . .	23
9	Pin input voltage . . . . .	24
10	Power supply scheme . . . . .	24
11	Current consumption measurement scheme . . . . .	25
12	Typical current consumption in standby mode vs. temperature at $V_{DD} = 3.3V$ . . . . .	31
13	High-speed external clock source AC timing diagram . . . . .	33
14	Low-speed external clock source AC timing diagram . . . . .	34
15	Typical application with an 8 MHz crystal . . . . .	35
16	Typical application with a 32.768 kHz crystal . . . . .	36
17	I/O AC characteristics . . . . .	45
18	Recommended NRST pin protection . . . . .	46
19	I2C bus AC waveform and measurement circuit <sup>(1)</sup> . . . . .	48
20	SPI timing diagram-slave mode and CPHA = 0 . . . . .	51
21	SPI timing diagram-slave mode and CPHA = 1 <sup>(1)</sup> . . . . .	52
22	SPI timing diagram-master mode <sup>(1)</sup> . . . . .	53
23	Typical connection diagram using the ADC . . . . .	56
24	Power supply and reference power supply decoupling circuit . . . . .	57
25	LQFP48 - 48-pin low-profile quad flat package outline . . . . .	58
26	LQFP32 - 32-pin low-profile quad flat package outline . . . . .	60
27	QFN32 - 32-pin quad flat no-leads package outline . . . . .	62
28	QFN20 - 20-pin quad flat no-leads package outline . . . . .	64
29	TSSOP20 - 20-lead thin shrink small outline package outline . . . . .	66
30	Ordering information scheme . . . . .	68

## List of Tables

1	MM32F031xx device features and peripheral counts . . . . .	3
2	Timer feature comparison . . . . .	6
3	Pin definitions . . . . .	15
4	Alternate functions for port A . . . . .	19
5	Alternate functions for port B . . . . .	20
6	Alternate functions for port C . . . . .	20
7	Alternate functions for port D . . . . .	20
8	Memory mapping . . . . .	21
9	Voltage characteristics . . . . .	25
10	Current characteristics . . . . .	25
11	Thermal characteristics . . . . .	26
12	General operating conditions . . . . .	26
13	Operating conditions at power-up/power-down . . . . .	27
14	Embedded reset and power control block characteristics . . . . .	27
15	Embedded internal reference voltage <sup>(1)</sup> . . . . .	28
16	Typical current consumption in Run mode, code executing from Flash memory . . . . .	29
17	Typical current consumption in Sleep mode, code executing from Flash memory or RAM . . . . .	30
18	Maximum current consumption in Stop and Standby mode, code executing from Flash memory . . . . .	30
19	On-chip peripheral current consumption <sup>(1)</sup> . . . . .	32
20	High-speed external user clock characteristics . . . . .	32
21	Low-speed external user clock characteristics . . . . .	33
22	HSE oscillator characteristics <sup>(1)(2)</sup> . . . . .	34
23	LSI oscillator characteristics ( $f_{LSE}=32.768\text{KHz}$ ) <sup>(1)</sup> . . . . .	36
24	HSI oscillator characteristics <sup>(1)(2)</sup> . . . . .	37
25	LSI oscillator characteristics <sup>(1)</sup> . . . . .	37
26	Low-power mode wakeup timings . . . . .	38
27	PLL characteristics <sup>(1)</sup> . . . . .	38
28	Flash memory characteristics . . . . .	38
29	Flash memory endurance and data retention <sup>(1)(2)</sup> . . . . .	39
30	EMS characteristics . . . . .	40
31	ESD characteristics . . . . .	41
32	I/O static characteristics . . . . .	41
33	Output voltage characteristics . . . . .	42
34	I/O AC characteristics <sup>(1)</sup> . . . . .	43
35	NRST pin characteristics . . . . .	45
36	TIMx <sup>(1)</sup> characteristics . . . . .	46
37	I2C characteristics . . . . .	47
38	SPI characteristics <sup>(1)</sup> . . . . .	48
39	ADC characteristics . . . . .	53
40	Maximum $R_{AIN}$ at $f_{ADC} = 15\text{MHz}$ <sup>(1)</sup> . . . . .	54
41	ADC Accuracy - Limit Test Conditions <sup>(1)(2)</sup> . . . . .	55
42	Temperature sensor characteristics <sup>(3)(4)</sup> . . . . .	57

43	LQFP48 mechanical data . . . . .	59
44	LQFP32 mechanical data . . . . .	60
45	QFN32 mechanical data . . . . .	62
46	QFN20 mechanical data . . . . .	64
47	TSSOP20 mechanical data . . . . .	66
48	Document revision history . . . . .	69

# 1

## Introduction

### Introduction

### 1.1 Description

MM32F031x4x6 (named as "the device" throughout this document) is ARM® Cortex™-M0 32-bit RISC core based micro controller family. The device has high speed embedded memory and the CPU, memory and AHB bus subsystem speed can attain up to 72MHz. The device also has integrated with extensive range of enhanced I/Os, two APB buses peripherals, 1 12-bit ADC, 2 general purpose 16-bit timers, 3 Basic timers, 1 Advanced 16-bit timer, and standard communication interfaces device: 1 I2C, 1 SPI, and 1 UART.

The device works between 2.0V to 5.5V range. The normal temperature for the device is -40°C to +85°C and -40°C to +105°C extended temperature range devices are also available upon ordering. A comprehensive set of power-saving mode allows the design of low-power applications.

The devices are available in 5 different packages: LQFP48, LQFP32, QFN32, QFN20 and TSSOP20. Depending on the device chosen, different sets of peripherals are included.

The abundant peripheral configurations enable the device to fit wide range of applications in difference industries, Few examples are as follows:

- Motor drive and application control
- Healthcare and fitness equipment
- PC peripherals, gaming, GPS equipment
- Industrial Applications: Programmable Controllers (PLCs), Inverters, Printers and Scanners
- Alarm system, wired and wireless sensors, video intercom

### 1.2 Product Features

- Core and system
  - ARM® Cortex™-M0 CPU
  - Maximum operating frequency is up to 72MHz
  - Single cycle 32-bit hardware multiplier
- Memories
  - 32K Bytes of Flash memory
  - 4K Bytes of SRAM
  - Boot loader support Chip Flash and ISP (In-System Programming)

- Clock, reset and power management
  - 2.0V to 5.5V application supply
  - Power-on/Power-down reset (POR/PDR), Programmable voltage detector (PVD)
  - External 2 to 24MHz high speed crystal oscillator
  - Embedded factory-tuned 48/72MHz high speed oscillator
  - Embedded 40KHz low speed oscillator
- Low-power
  - Sleep, Stop and Standby modes
- 1 12-bit ADC, 1 $\mu$ S A/D converters (up to 10 channels)
  - Conversion range: 0 to  $V_{DDA}$
  - Support sampling time and resolution configuration
  - On-chip temperature sensor
  - On-chip voltage sensor
- 5 DMA controller
  - Supported peripherals: Timer, UART, I2C, SPI and ADC
- Up to 39 fast I/Os:
  - All mappable on 16 external interrupt vectors
  - Almost all can work on 5V
- Debug mode
  - Serial wire debug (SWD)
- Up to 9 timers
  - 1 16-bit 4-channel advanced-control timer for 4 channels PWM output, with deadtime generation and emergency stop
  - 2 16-bit timer, with up to 4 IC/OC, usable for IR control decoding
  - 2 16-bit timer, with 1 IC/OC, 1 OCN, deadtime generation and emergency stop and modulator gate for IR control
  - 1 16-bit timer, with 1 IC/OC
  - 2 watchdog timers (independent and window type)
  - SysTick timer: 24-bit downcounter
- Up to 3 Communication interfaces
  - 1 UART
  - 1 I2C
  - 1 SPI
- 96-bit unique ID (UID)
- Packages LQFP48, LQFP32, QFN32, QFN20 and TSSOP20

For more information about the complete product, refer to Section 2.2 of the data sheet. The relevant information about the Cortex<sup>TM</sup>-M0, please refer to Cortex<sup>TM</sup>-M0 technical reference manual.



# 2 Specification

Specification

## 2.1 Device contrast

Table 1. MM32F031xx device features and peripheral counts

Peripheral		Device				
		MM32F031C4/6T	MM32F031K4/6T	MM32F031K4/6U	MM32F031F4/6P	MM32F031F4/6U
Flash memory -K Bytes		16/32	16/32	16/32	16/32	16/32
SRAM -K Bytes		4	4	4	4	4
Timers	General purpose (16 bit)	5	5	5	5	5
	Advanced control	1	1	1	1	1
Common interfaces	UART	1	1	1	1	1
	I2C	1	1	1	1	1
	SPI	1	1	1	1	1
GPIOs		39	25	27	16	16
12-bit ADC (number of channels)		1 10 channels			1 9 channels	
Max CPU frequency		72 MHz				
Operating voltage		2.0V ~ 5.5V				
Packages		LQFP48	LQFP32	QFN32	QFN20	TSSOP20

## 2.2 Summary

### 2.2.1 ARM® Cortex™-M0 and SRAM

The ARM® Cortex™-M0 is a generation of ARM processors for embedded systems. It has been developed to provide a low-cost platform that meets the needs of MCU implementation, with a reduced pin count and low-power consumption, while delivering outstanding computational performance and an advanced system response to interrupts.

The ARM® Cortex™-M0 processors feature exceptional code-efficiency, delivering the high performance expected from an ARM core, with memory sizes usually associated with 8- and 16-bit devices.

The devices have embedded ARM core and are compatible with all ARM tools and software.

### 2.2.2 Memory

32K Bytes of embedded Flash memory.

### 2.2.3 SRAM

4K Bytes of embedded SRAM.

### 2.2.4 Clocks and startup

When the system is powered up, the default clock is from PLL with the resource from HSE 48 MHz oscillator. An external 2 ~ 24 MHz clock can also be configured to monitor the system during power up phases.

Several prescalers allow the application to configure the frequency of the AHB and the APB domains. The maximum frequency of the AHB and the APB domains is 72MHz. Refer to figure 2 for the clock drive block diagram.

### 2.2.5 Nested vectored interrupt controller (NVIC)

The device embeds a nested vectored interrupt controller and is able to handle up to 68 maskable interrupt channels (not including the 16 interrupt lines of Cortex™-M0) with 16 priority levels.

- Closely coupled NVIC gives low latency interrupt processing
- Interrupt entry vector table address passed directly to the core
- Closely coupled NVIC core interface
- Allows early processing of interrupts
- Processing of late arriving higher priority interrupts
- Support for tail-chaining
- Processor state automatically saved
- Interrupt entry restored on interrupt exit with no instruction overhead

This hardware block provides flexible interrupt management features with minimal interrupt latency.

### 2.2.6 Extended interrupt/event controller (EXTI)

The extended interrupt/event controller consists of many edge detector lines are used to generate interrupt/event requests for waking up the system. Each line can be independently configured to select the trigger event (rising edge, falling edge, both) and can be masked independently. A pending register maintains the status of the interrupt requests. The EXTI can detect an external line with a pulse width shorter than the internal APB2 clock period. All GPIOs can be connected to the 16 external interrupt lines.

## 2.2.7 Boot modes

At startup, the boot pin and boot selector option bit are used to select one of the three boot options:

- Boot from User Flash memory
- Boot from System Memory
- Boot from embedded SRAM

## 2.2.8 Power supply schemes

- $V_{DD} = 2.0V \sim 5.5V$ : external power supply for I/Os and the internal regulator. Provided externally through  $V_{DD}$  pins.
- $V_{SSA}, V_{DDA} = 2.0V \sim 5.5V$ : Provides power to the reset module and oscillator.  $V_{DDA}$  and  $V_{SSA}$  must be connected to  $V_{DD}$  and  $V_{SS}$ .

## 2.2.9 Power supply supervisors

The device has integrated power-on reset (POR) and power-down reset (PDR) circuits. They are always active, and ensure proper operation above a threshold of 1.8V. The device remains in reset mode when the monitored supply voltage is below a specified threshold  $V_{POR/PDR}$ , without the need for an external reset circuit.

The device features an embedded programmable voltage detector (PVD) that monitors the  $V_{DD}/V_{DDA}$  power supply and compares it to the  $V_{PVD}$  threshold. An interrupt can be generated when  $V_{DD}$  drops below the  $V_{PVD}$  threshold and/or when  $V_{DD}$  is higher than the  $V_{PVD}$  threshold. The interrupt service routine can then generate a warning message and/or put the MCU into a safe state. The PVD is enabled by software.

## 2.2.10 Voltage regulator

The voltage regulator converts the external voltage to the internal digital logic and it is always enabled after reset.

## 2.2.11 Low-power modes

The device support three low-power modes to achieve the best compromise between low power consumption, short startup time and available wakeup sources.

### Sleep mode

In Sleep mode, only the CPU is stopped. All peripherals continue to operate and can wake up the CPU when an interrupt/event occurs.

### Stop mode

Stop mode achieves very low power consumption while retaining the content of SRAM and registers. the HSI and the HSE crystal oscillators are disabled. The voltage regulator

can also be put either in normal or in low power mode.

### Standby mode

Standby mode achieves the lowest power consumption of the system. This mode turns off the voltage regulator in CPU deep sleep mode. The entire 1.5V power supply area is powered down. HSI and HSE oscillators are also powered down. SRAM and register contents are missing.

### 2.2.12 Direct memory access controller (DMA)

The 5-channel general-purpose DMAs manage memory-to-memory, peripheral-to-memory and memory-to-peripheral transfers. The DMA supports circular buffer management, removing the need for user code intervention when the controller reaches the end of the buffer.

Each channel is connected to dedicated hardware DMA requests, with support for software trigger on each channel. Configuration is made by software and transfer sizes between source and destination are independent.

DMA can be used with the main peripherals: UART、I2C、SPI、ADC general-purpose and advanced-control timers TIMx.

### 2.2.13 Timers and watchdogs

Medium capacity device include 1 advanced control、2 general-purpose timers、3 base-timer、2 watchdog timers and 1 SysTick timer.

The following table compares the features of the different timers:

Table 2. Timer feature comparison

Timer type	Timer	Counter resolution	Counter type	Prescaler factor	DMA request generation	Capture/-compare channels	Complementary outputs
Advanced control	TIM1	16-bit	Up, down, up/down	integer from 1 to 65536	Yes	4	Yes
General purpose	TIM2	16-bit	Up, down, up/down	integer from 1 to 65536	Yes	4	No
	TIM3	16-bit	Up, down, up/down	integer from 1 to 65536	Yes	4	No
basic	TIM14	16-bit	Up	integer from 1 to 65536	Yes	1	No

Timer type	Timer	Counter resolution	Counter type	Prescaler factor	DMA request generation	Capture/-compare channels	Complementary outputs
	TIM16 / TIM17	16-bit	Up	integer from 1 to 65536	Yes	1	Yes

### Advanced-control timer ( TIM1 )

The advanced-control timer can be seen as a three-phase PWM multiplexed on six channels. It has complementary PWM outputs with programmable inserted dead times. It can also be seen as a complete general-purpose timer. The four independent channels can be used for:

- Input capture
- Output compare
- PWM generation (edge or center-aligned modes)
- One-pulse mode output

If configured as a standard 16-bit timer, it has the same features as the TIMx timer. If configured as the 16-bit PWM generator, it has full modulation capability (0 ~ 100%).

In debug mode, the counter can be frozen and the PWM output is disabled to cut off the switches controlled by these outputs.

Many features are shared with those of the standard timers which have the same architecture. The advanced control timer can therefore work together with the other timers via the Timer Link feature for synchronization or event chaining.

### General-purpose timers (TIMx)

There are 2 synchronizable general-purpose timers ( TIM2、TIM3 ).

#### General-purpose timers 16-bit

##### TIM3

The timer is based on a 16-bit auto-reload up/downcounter and a 16-bit prescaler. The feature is 4 independent channels each for input capture/output compare, PWM or one-pulse mode output.

The timer can work together or with the TIM1 advanced-control timer via the Timer Link feature for synchronization or event chaining. Their counter can be frozen in debug mode. Any of the general-purpose timers can be used to generate PWM outputs. They all have independent DMA request generation.

These timers are capable of handling quadrature (incremental) encoder signals and the digital outputs from 1 to 3 hall-effect sensors.

## Basic timer

### TIM14

This timer is based on a 16-bit auto-reload upcounter and a 16-bit prescaler. TIM14 features one single channel for input capture/output compare, PWM or one-pulse mode output. Their counter can be frozen in debug mode.

### TIM16/TIM17

Every timer is based on a 16-bit auto-reload upcounter and a 16-bit prescaler. They each have a single channel for input capture/output compare, PWM or one-pulse mode output. TIM16 and TIM17 have a complementary output with dead-time generation and independent DMA request generation. Their counters can be frozen in debug mode.

## Independent watchdog (IWDG)

The independent watchdog is based on an 8-bit prescaler and 12-bit downcounter with user-defined refresh window. It is clocked from an independent 40 KHz internal oscillator and as it operates independently from the main clock, it can operate in Stop and Standby modes. It can be used either as a watchdog to reset the device when a problem occurs, or as a free running timer for application timeout management. It is hardware or software configurable through the option bytes. The counter can be frozen in debug mode.

## System window watchdog (WWDG)

The system window watchdog is based on a 7-bit downcounter that can be set as free running. It can be used as a watchdog to reset the device when a problem occurs. It is clocked from the APB clock (PCLK). It has an early warning interrupt capability and the counter can be frozen in debug mode.

## SysTick timer

This timer is dedicated to real-time operating systems, but could also be used as a standard down counter. It features:

- A 24-bit down counter
- Autoreload capability
- Maskable system interrupt generation when the counter reaches 0
- Programmable clock source

### 2.2.14 Universal asynchronous receiver/transmitter (UART)

UART provides hardware management of the CTS, RTS.

Support LIN master-slave function.

All UART interface can be served by the DMA controller.

### 2.2.15 I2C interface

The I2C interface can operate in multimaster or slave modes. It can support Standard mode, and Fast Mode.

It supports 7-bit and 10-bit addressing modes, multiple 7-bit slave addresses (two addresses, one with configurable mask).

### 2.2.16 Serial peripheral interface (SPI)

The SPI interface, in slave or master mode, can be configured to 1 ~ 32 bits per frame.

All SPI interface can be served by the DMA controller.

### 2.2.17 General-purpose inputs/outputs (GPIO)

Each of the GPIO pins can be configured by software as output (push-pull or open-drain), as input (with or without pull-up or pull-down) or as peripheral alternate function. Most of the GPIO pins are shared with digital or analog alternate functions. The I/O configuration can be locked if needed following a specific sequence in order to avoid spurious writing to the I/Os registers.

### 2.2.18 Analog-to-digital converter (ADC)

The one 12-bit analog-to-digital converters is embedded into microcontrollers and the ADC shares up to 10 external channels, performing conversions in single-shot or scan modes. In scan mode, automatic conversion is performed on a selected group of analog inputs. The ADC can be served by the DMA controller.

The analog watchdog function allows very precise monitoring of all the way, multiple or all selected channels, and an interruption occurs when the monitored signal exceeds the preset threshold. The events generated by the general-purpose timers (TIMx) and the advanced-control timer (TIM1) can be internally connected to the ADC start trigger to allow the application to synchronize A/D conversion and timers.

### 2.2.19 Temperature sensor

The temperature sensor has to generate a voltage that varies linearly with temperature. The temperature sensor is internally connected to the input channel which is used to convert the sensor output voltage into a digital value.

### 2.2.20 Serial single line SWD debug port (SW-DP)

Built-in ARM two-wire serial debug port (SW-DP).

An ARM SW-DP interface is provided to allow a serial wire debugging tool to be connected to the MCU.

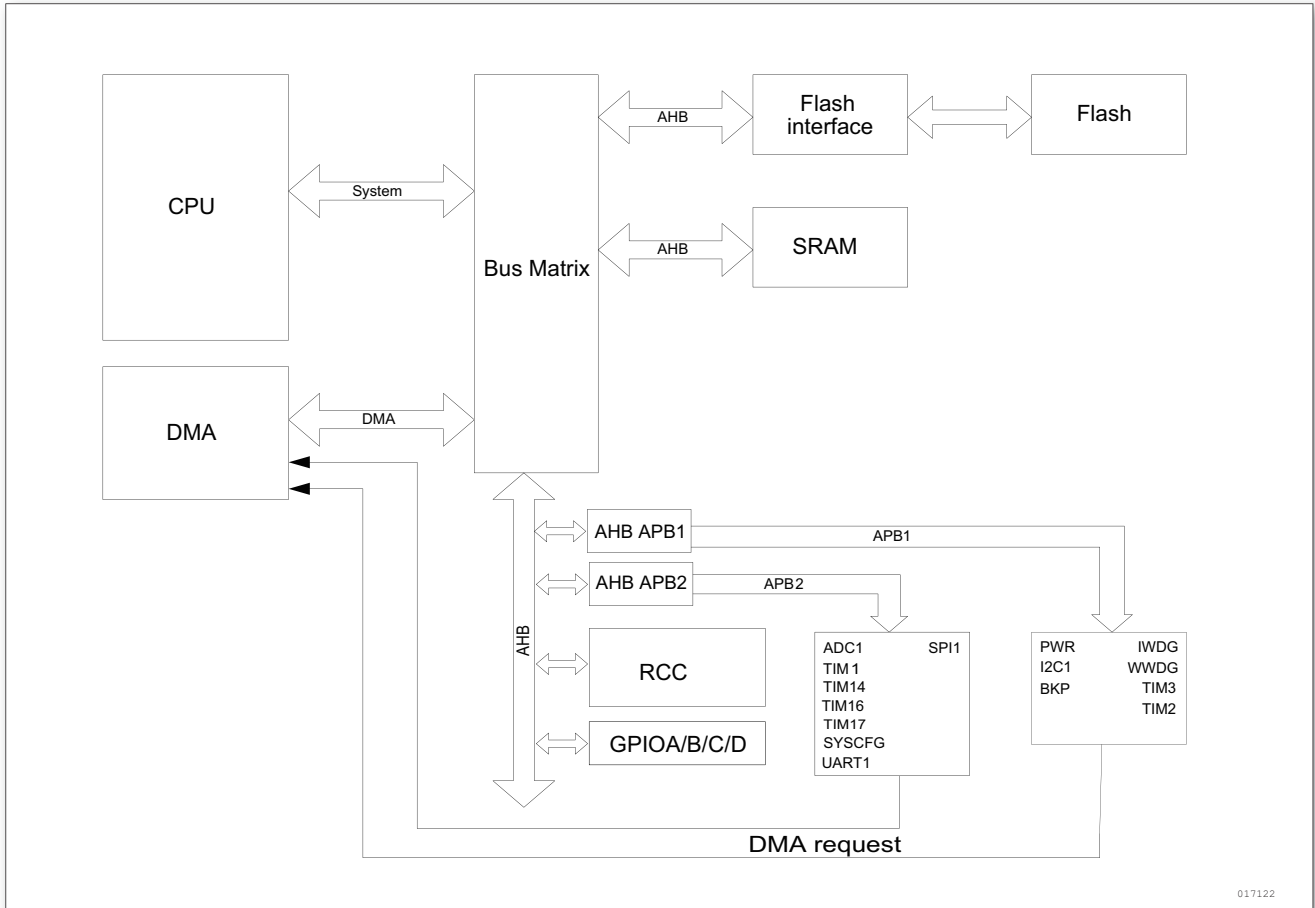

017122

Figure 1. Block diagram



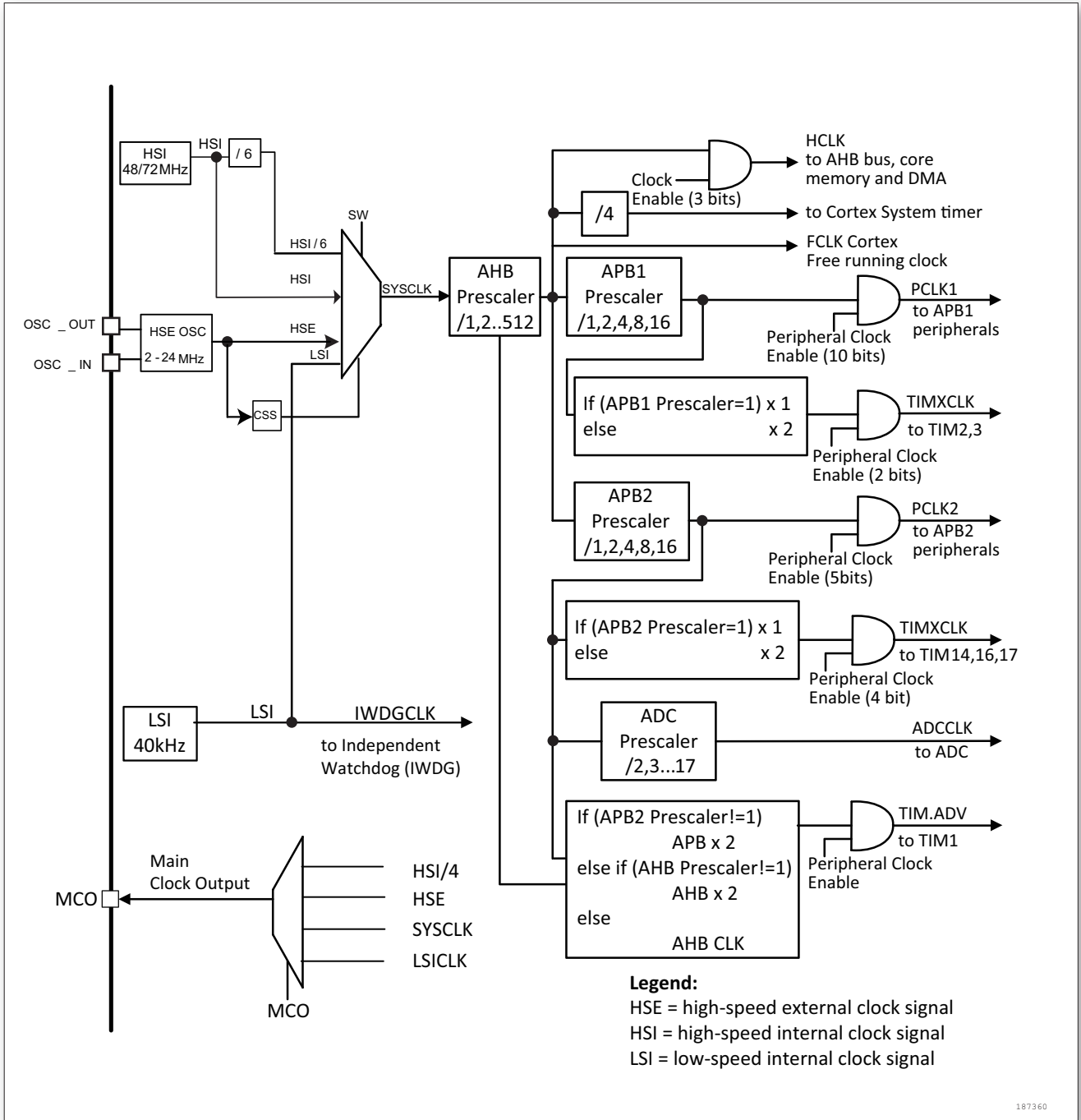

Figure 2. Clock tree

# 3

## Pin definition

Pin definition

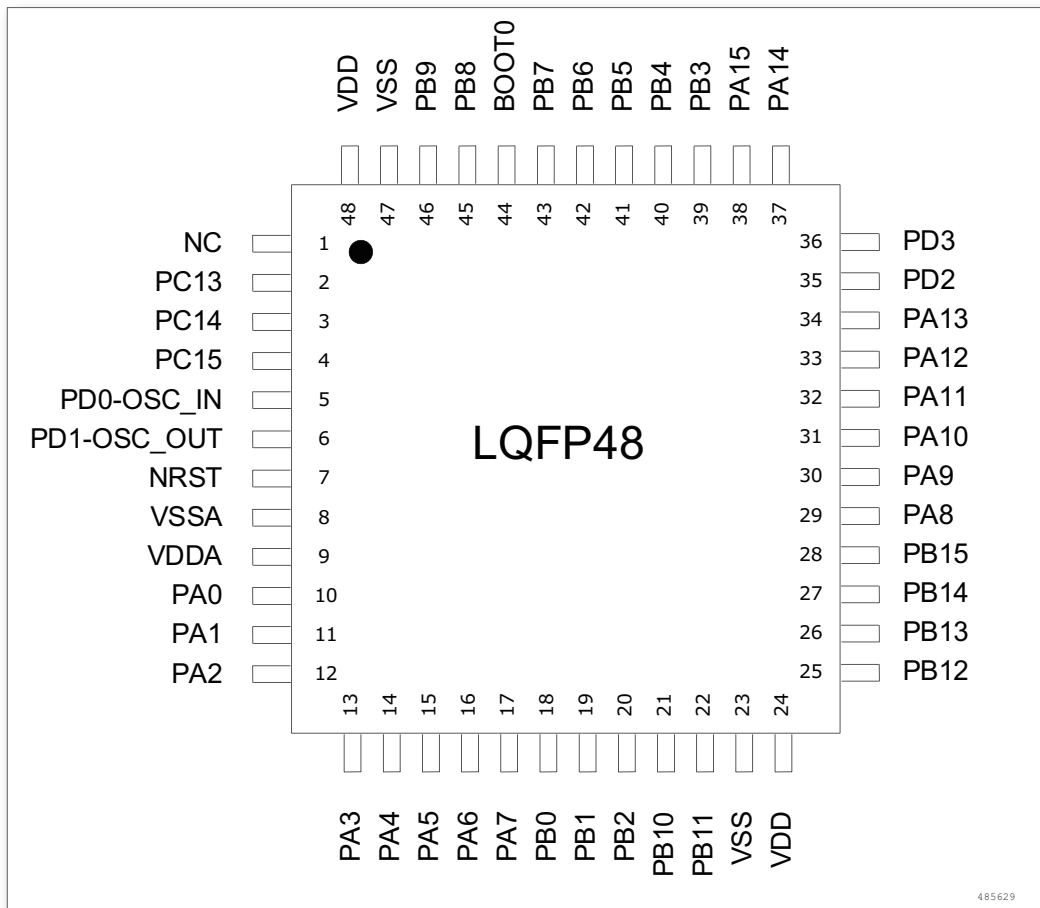

Figure 3. LQFP48 packet pinout

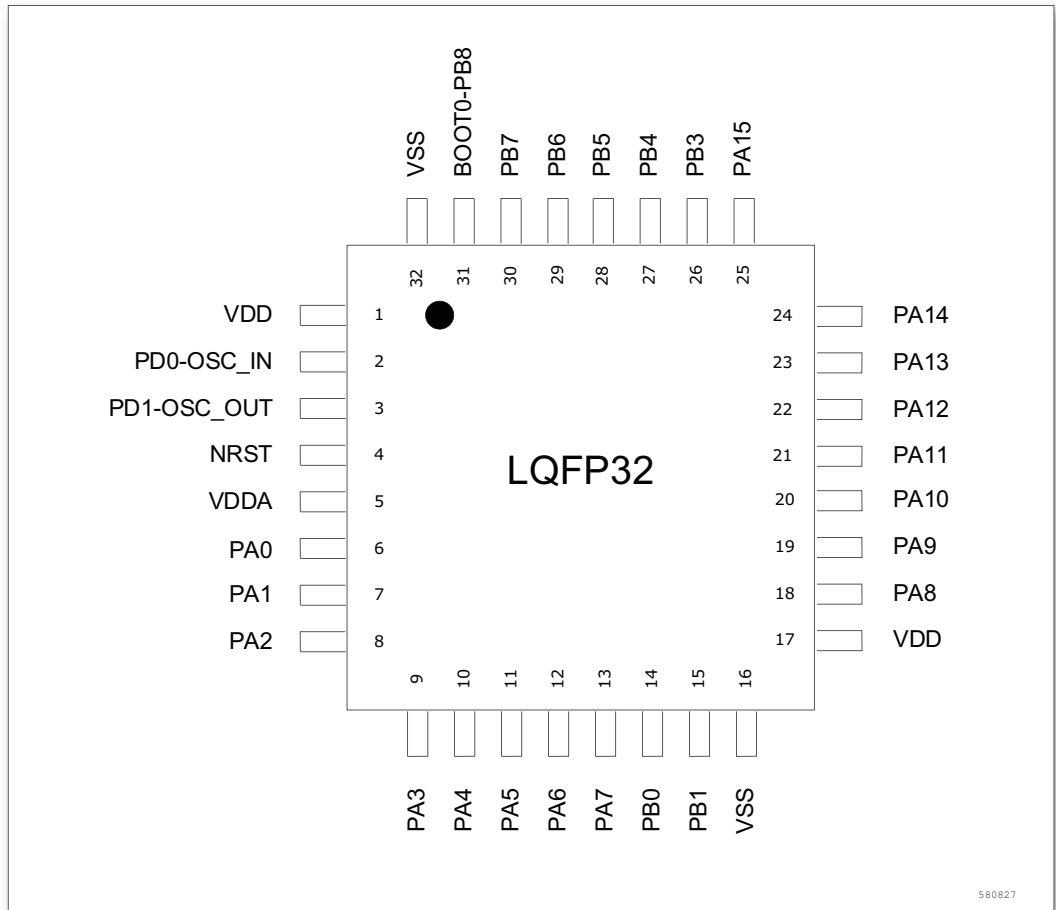

Figure 4. LQFP32 packet pinout

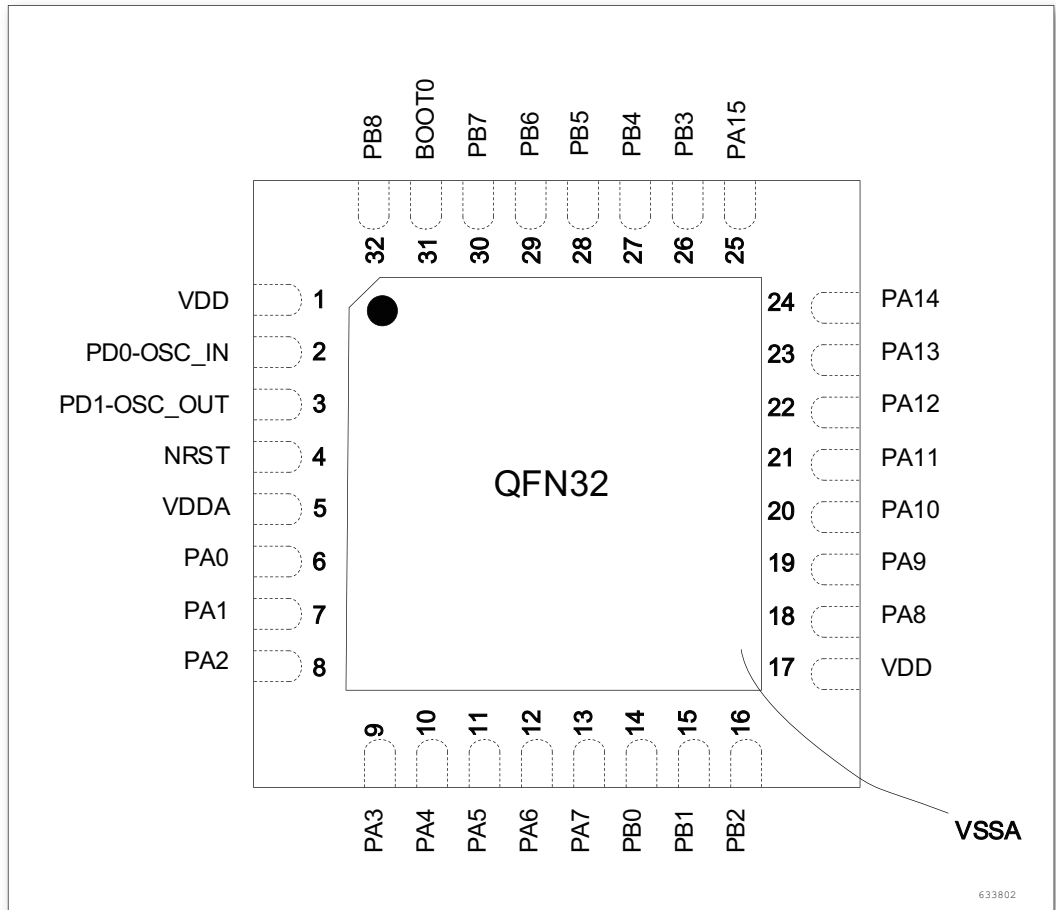

Figure 5. QFN32 packet pinout

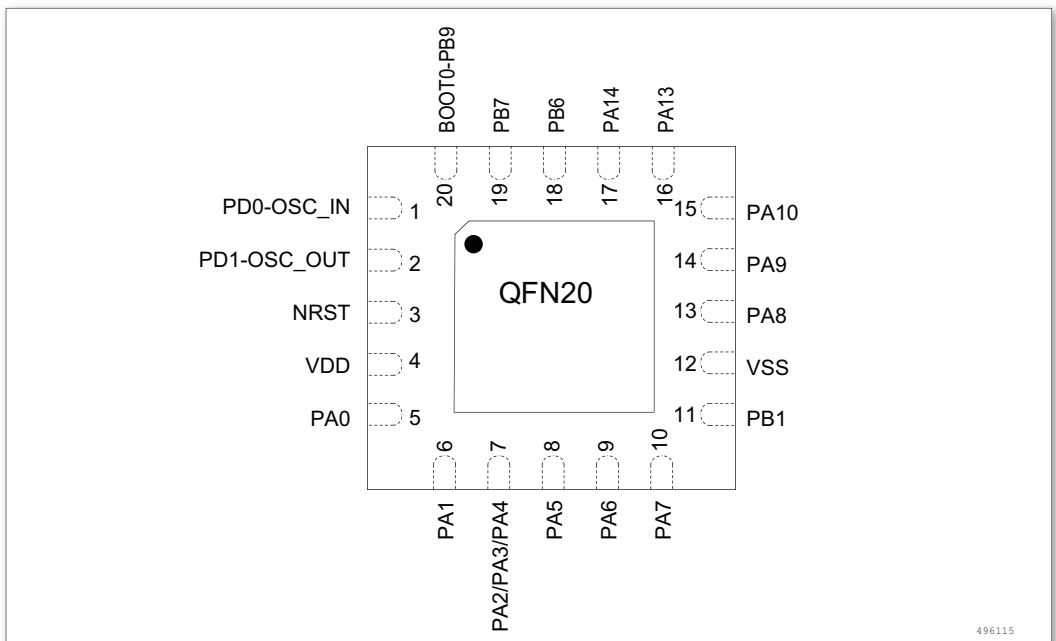

Figure 6. QFN20 packet pinout

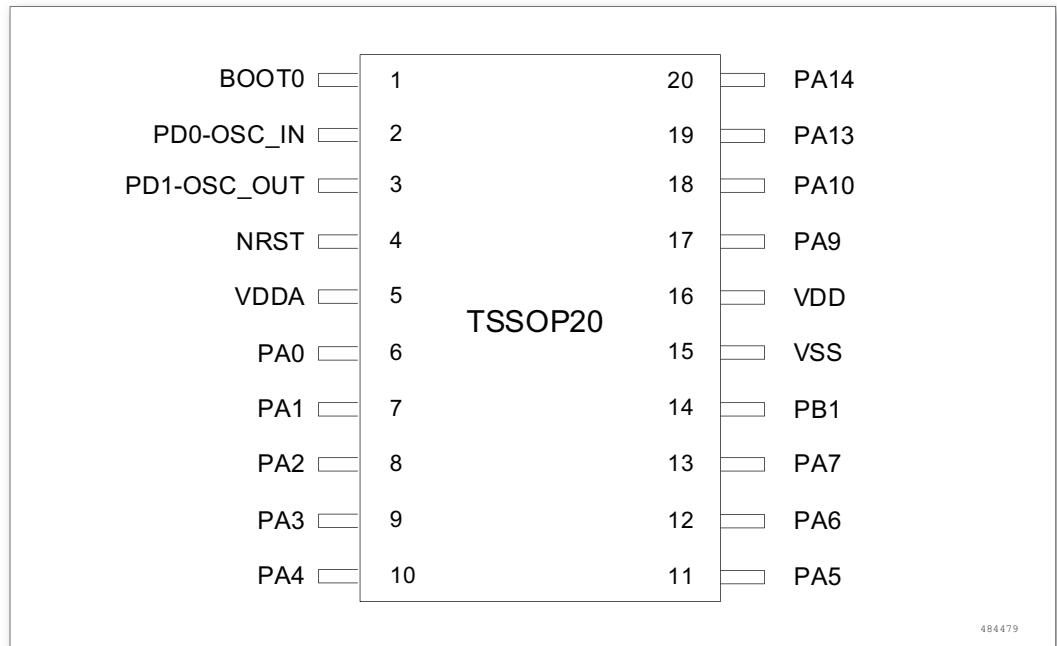

Figure 7. TSSOP20 packet pinout

Table 3. Pin definitions

Pin number					Pin name	Type <sup>(1)</sup>	I/O structure <sup>(2)</sup>	Main function	Alternate functions	Additional functions
LQFP 48	LQFP 32	QFN 32	QFN 20	TSSOP 20						
1	-	-	-	-	NC	S	-	NC	-	-
2	-	-	-	-	PC13	I/O	FT	PC13	TIM2_CH1	-
3	-	-	-	-	PC14	I/O	FT	PC14	TIM2_CH2	-
4	-	-	-	-	PC15	I/O	FT	PC15	TIM2_CH3	-
5	2	2	1	2	PD0 OSC_IN	I/O	FT	PD0	I2C1_SDA	-
6	3	3	2	3	PD1 OSC_OUT	I/O	FT	PD1	I2C1_SCL	-
7	4	4	3	4	NRST	I/O	FT	NRST	-	-
8	-	0	-	-	VSSA	S	-	VSSA	-	-
9	5	5	4	5	VDDA	S	-	VDDA	-	-
10	6	6	5	6	PA0	I/O	TC	PA0	TIM2_CH1_ETR/ TIM2_CH3	ADC1_VIN[0]
11	7	7	6	7	PA1	I/O	TC	PA1	TIM2_CH2	ADC1_VIN[1]
12	8	8	7	8	PA2	I/O	TC	PA2	TIM2_CH3	ADC1_VIN[2]
13	9	9	7	9	PA3	I/O	TC	PA3	TIM2_CH4	ADC1_VIN[3]
14	10	10	7	10	PA4	I/O	TC	PA4	SPI1_NSS/ TIM1_BKIN/ TIM14_CH1/ I2C1_SDA	ADC1_VIN[4]

Pin number					Pin name	Type <sup>(1)</sup>	I/O structure <sup>(2)</sup>	Main function	Alternate functions	Additional functions
LQFP 48	LQFP 32	QFN 32	QFN 20	TSSOP 20						
15	11	11	8	11	PA5	I/O	TC	PA5	SPI1_SCK/ TIM2_CH1_ETR/ TIM1_ETR/ I2C1_SCL/ TIM1_CH3N	ADC1_VIN[5]
16	12	12	9	12	PA6	I/O	TC	PA6	SPI1_MISO/ TIM3_CH1/ TIM1_BKIN/ TIM1_ETR/ TIM16_CH1/ TIM1_CH3	ADC1_VIN[6]
17	13	13	10	13	PA7	I/O	TC	PA7	SPI1_MOSI/ TIM3_CH2/ TIM1_CH1N/ TIM14_CH1/ TIM17_CH1/ TIM1_CH2N/ TIM1_CH3N	ADC1_VIN[7]
18	14	14	-	-	PB0	I/O	TC	PB0	TIM3_CH3/ TIM1_CH2N/ TIM1_CH1N/ TIM1_CH3	ADC1_VIN[8]
19	15	15	11	14	PB1	I/O	TC	PB1	TIM14_CH1/ TIM3_CH4/ TIM1_CH3N/ TIM1_CH4/ TIM1_CH2N/ MCO/ TIM1_CH2/ TIM1_CH1N	ADC1_VIN[9]
20	-	16	-	-	PB2	I/O	FT	PB2	-	-
21	-	-	-	-	PB10	I/O	FT	PB10	I2C1_SCL/ TIM2_CH3	-
22	-	-	-	-	PB11	I/O	FT	PB11	I2C1_SDA/ TIM2_CH4	-
23	16	0	-	15	VSS	S	-	VSS	-	-
24	17	17	-	16	VDD	S	-	VDD	-	-

Pin number					Pin name	Type <sup>(1)</sup>	I/O structure <sup>(2)</sup>	Main function	Alternate functions	Additional functions
LQFP 48	LQFP 32	QFN 32	QFN 20	TSSOP 20						
					PB12	I/O	FT	PB12	TIM1_BKIN	-
					PB13	I/O	FT	PB13	TIM1_CH1N/ I2C1_SCL/ TIM1_CH3N/ TIM2_CH1	-
					PB14	I/O	FT	PB14	TIM1_CH2N/ I2C1_SDA/ TIM1_CH3/ TIM1_CH1	-
					PB15	I/O	FT	PB15	TIM1_CH3N/ TIM1_CH2N/ TIM1_CH2	-
					PA8	I/O	FT	PA8	MCO/ TIM1_CH1/ TIM1_CH2/ TIM1_CH3	-
					PA9	I/O	FT	PA9	UART1_TX/ TIM1_CH2/ UART1_RX/ I2C1_SCL/ MCO/ TIM1_CH1N/ TIM1_CH4	-
					PA10	I/O	FT	PA10	TIM17_BKIN/ UART1_RX/ TIM1_CH3/ UART1_TX/ I2C1_SDA/ TIM1_CH1	-
					PA11	I/O	FT	PA11	UART1_CTS/ TIM1_CH4/ I2C1_SCL	-
					PA12	I/O	FT	PA12	UART1_RTS/ TIM1_ETR/ I2C1_SDA/ TIM1_CH2	-

Pin number					Pin name	Type <sup>(1)</sup>	I/O structure <sup>(2)</sup>	Main function	Alternate functions	Additional functions
LQFP 48	LQFP 32	QFN 32	QFN 20	TSSOP 20						
34	23	23	16	19	PA13	I/O	FT	PA13	SWDIO/ MCO/ TIM1_CH2/ TIM1_BKIN	-
35	-	-	-	-	PD2	I/O	FT	PD2	-	-
36	-	-	-	-	PD3	I/O	FT	PD3	-	-
37	24	24	17	20	PA14	I/O	FT	PA14	SWDCLK/ SPI1_NSS	-
38	25	25	-	-	PA15	I/O	FT	PA15	SPI1_NSS/ TIM2_CH1_ETR	-
39	26	26	-	-	PB3	I/O	TC	PB3	SPI1_SCK/ TIM2_CH2/ UART1_TX/ TIM2_CH3/ TIM1_CH1/ TIM2_CH1	ADC1_VIN[10]
40	27	27	-	-	PB4	I/O	TC	PB4	SPI1_MISO/ TIM3_CH1/ UART1_RX/ TIM17_BKIN/ TIM1_CH2/ TIM2_CH2	ADC1_VIN[11]
41	28	28	-	-	PB5	I/O	FT	PB5	SPI1_MOSI/ TIM3_CH2/ TIM16_BKIN/ MCO/ TIM1_CH3/ TIM2_CH3	-
42	29	29	18	-	PB6	I/O	FT	PB6	UART1_TX/ I2C1_SCL/ TIM16_CH1N/ TIM2_CH1	-
43	30	30	19	-	PB7	I/O	TC	PB7	UART1_RX/ I2C1_SDA/ TIM17_CH1N	ADC1_VIN[12]
44	31	31	20	1	BOOT0	I	FT	BOOT0	-	-



Pin number					Pin name	Type <sup>(1)</sup>	I/O structure <sup>(2)</sup>	Main function	Alternate functions	Additional functions
LQFP 48	LQFP 32	QFN 32	QFN 20	TSSOP 20						
45	31	32	-	-	PB8	I/O	FT	PB8	I2C1_SCL/ TIM16_CH1	-
46	-	-	20	-	PB9	I/O	FT	PB9	I2C1_SDA/ TIM17_CH1/ TIM1_CH4	-
47	32	0	-	-	VSS	S	-	VSS	-	-
48	1	1	-	-	VDD	S	-	VDD	-	-

1. I = input, O = output, S = power supply, HiZ = high resistance.

2. FT: 5V tolerant, Input signal should be between VDD and 5V.

TC: Standard I/O, Input signal does not exceed VDD.

Table 4. Alternate functions for port A

Pin Name	AF0	AF1	AF2	AF3	AF4	AF5	AF6	AF7
PA0	-	-	TIM2_CH1 _ETR	-	TIM2_CH3	-	-	-
PA1	-	-	TIM2_CH2	-	-	-	-	-
PA2	-	-	TIM2_CH3	-	-	-	-	-
PA3	-	-	TIM2_CH4	-	-	-	-	-
PA4	SPI1_NSS	-	-	TIM1_BKIN	TIM14_CH1	I2C1_SDA	-	-
PA5	SPI1_SCK	-	TIM2_CH1 _ETR	TIM1_ETR	-	I2C1_SCL	TIM1_CH3N	-
PA6	SPI1_MISO	TIM3_CH1	TIM1_BKIN	-	TIM1_ETR	TIM16_CH1	TIM1_CH3	-
PA7	SPI1_MOSI	TIM3_CH2	TIM1_CH1N	-	TIM14_CH1	TIM17_CH1	TIM1_CH2N	TIM1_CH3N
PA8	MCO	-	TIM1_CH1	-	-	-	TIM1_CH2	TIM1_CH3
PA9	-	UART1_TX	TIM1_CH2	UART1_RX	I2C1_SCL	MCO	TIM1_CH1N	TIM1_CH4
PA10	TIM17_BKIN	UART1_RX	TIM1_CH3	UART1_TX	I2C1_SDA	-	TIM1_CH1	-
PA11	-	UART1_CTS	TIM1_CH4	-	-	I2C1_SCL	-	-
PA12	-	UART1_RTS	TIM1_ETR	-	-	I2C1_SDA	-	TIM1_CH2
PA13	SWDIO	-	-	-	-	MCO	TIM1_CH2	TIM1_BKIN
PA14	SWDCLK	-	-	SPI1_NSS	-	-	-	-
PA15	SPI1_NSS	-	TIM2_CH1 _ETR	-	-	-	-	-

Table 5. Alternate functions for port B

Pin Name	AF0	AF1	AF2	AF3	AF4	AF5	AF6	AF7
PB0	-	TIM3_CH3	TIM1_CH2N	TIM1_CH1N	TIM1_CH3	-	-	-
PB1	TIM14_CH1	TIM3_CH4	TIM1_CH3N	TIM1_CH4	TIM1_CH2N	MCO	TIM1_CH2	TIM1_CH1N
PB3	SPI1_SCK	-	TIM2_CH2	UART1_TX	TIM2_CH3	-	TIM1_CH1	TIM2_CH1
PB4	SPI1_MISO	TIM3_CH1	-	UART1_RX	-	TIM17_BKIN	TIM1_CH2	TIM2_CH2
PB5	SPI1_MOSI	TIM3_CH2	TIM16_BKIN	MCO	-	-	TIM1_CH3	TIM2_CH3
PB6	UART1_TX	I2C1_SCL	TIM16_CH1N	-	TIM2_CH1	-	-	-
PB7	UART1_RX	I2C1_SDA	TIM17_CH1N	-	-	-	-	-
PB8	-	I2C1_SCL	TIM16_CH1	-	-	-	-	-
PB9	-	I2C1_SDA	TIM17_CH1	-	TIM1_CH4	-	-	-
PB10	-	I2C1_SCL	TIM2_CH3	-	-	-	-	-
PB11	-	I2C1_SDA	TIM2_CH4	-	-	-	-	-
PB12	-	-	TIM1_BKIN	-	-	-	-	-
PB13	-	-	TIM1_CH1N	-	-	I2C1_SCL	TIM1_CH3N	TIM2_CH1
PB14	-	-	TIM1_CH2N	-	-	I2C1_SDA	TIM1_CH3	TIM1_CH1
PB15	-	-	TIM1_CH3N	-	-	-	TIM1_CH2N	TIM1_CH2

Table 6. Alternate functions for port C

Pin Name	AF0	AF1	AF2	AF3	AF4	AF5	AF6	AF7
PC13	-	-	-	-	-	-	TIM2_CH1	-
PC14	-	-	-	-	-	-	TIM2_CH2	-
PC15	-	-	-	-	-	-	TIM2_CH3	-

Table 7. Alternate functions for port D

Pin Name	AF0	AF1	AF2	AF3	AF4	AF5	AF6	AF7
PD0	-	I2C1_SDA	-	-	-	-	-	-
PD1	-	I2C1_SCL	-	-	-	-	-	-

## 4

## Memory mapping

Memory mapping

Table 8. Memory mapping

Bus	Boundaryaddress	Size	Peripheral	Notes
Flash	0x0000 0000 - 0x0001 FFFF	128 KB	Main flash memory, system memory, or SRAM, depends on the configuration of BOOT	
	0x0002 0000 - 0x07FF FFFF	~ 128 MB	Reserved	
	0x0800 0000 - 0x0800 7FFF	32 KB	Main Flash memory	
	0x0800 8000 - 0x1FFD FFFF	~ 256 MB	Reserved	
	0x1FFE 0000 - 0x1FFE 01FF	0.5 KB	Reserved	
	0x1FFE 0200 - 0x1FFE 0FFF	3 KB	Reserved	
	0x1FFE 1000 - 0x1FFE 1BFF	3 KB	Reserved	
	0x1FFE 1C00 - 0x1FFF F3FF	~ 256 MB	Reserved	
	0x1FFF F400 - 0x1FFF F7FF	1 KB	System memory	
	0x1FFF F800 - 0x1FFF F80F	16 B	Option bytes	
0x1FFF F810 - 0x1FFF FFFF	~ 2 KB	Reserved		
SRAM	0x2000 0000 - 0x2000 0FFF	4 KB	SRAM	
	0x2000 1000 - 0x2FFF FFFF	~ 512 MB	Reserved	
APB1	0x4000 0000 - 0x4000 03FF	1 KB	TIM2	
	0x4000 0400 - 0x4000 07FF	1 KB	TIM3	
	0x4000 0800 - 0x4000 27FF	8 KB	Reserved	
	0x4000 2C00 - 0x4000 2FFF	1 KB	WWDG	
	0x4000 3000 - 0x4000 33FF	1 KB	IWDG	
	0x4000 3400 - 0x4000 37FF	1 KB	Reserved	
	0x4000 3800 - 0x4000 3BFF	1 KB	Reserved	
	0x4000 4000 - 0x4000 43FF	1 KB	Reserved	
	0x4000 4400 - 0x4000 47FF	1 KB	Reserved	
	0x4000 4800 - 0x4000 4BFF	3 KB	Reserved	
	0x4000 5400 - 0x4000 57FF	1 KB	I2C1	
	0x4000 5800 - 0x4000 5BFF	1 KB	Reserved	
	0x4000 5C00 - 0x4000 5FFF	1 KB	Reserved	
	0x4000 6000 - 0x4000 63FF	1 KB	Reserved	
	0x4000 6400 - 0x4000 67FF	1 KB	Reserved	
0x4000 6800 - 0x4000 6BFF	1 KB	Reserved		

Bus	Boundaryaddress	Size	Peripheral	Notes
APB1	0x4000 6C00 - 0x4000 6FFF	1 KB	Reserved	
	0x4000 7000 - 0x4000 73FF	1 KB	PWR	
	0x4000 7400 - 0x4000 FFFF	35 KB	Reserved	
APB2	0x4001 0000 - 0x4001 03FF	1 KB	SYSCFG	
	0x4001 0400 - 0x4001 07FF	1 KB	EXTI	
	0x4001 0800 - 0x4001 23FF	7 KB	Reserved	
	0x4001 2400 - 0x4001 27FF	1 KB	ADC1	
	0x4001 2800 - 0x4001 2BFF	1 KB	Reserved	
	0x4001 2C00 - 0x4001 2FFF	1 KB	TIM1	
	0x4001 3000 - 0x4001 33FF	1 KB	SPI1	
	0x4001 3400 - 0x4001 37FF	1 KB	DBGMCU	
	0x4001 3800 - 0x4001 3BFF	1 KB	UART1	
	0x4001 3C00 - 0x4001 3FFF	1 KB	Reserved	
	0x4001 4000 - 0x4001 43FF	1 KB	TIM14	
	0x4001 4400 - 0x4001 47FF	1 KB	TIM16	
	0x4001 4800 - 0x4001 4BFF	1 KB	TIM17	
	0x4001 4C00 - 0x4001 7FFF	13 KB	Reserved	
AHB	0x4002 0000 - 0x4002 03FF	1 KB	DMA	
	0x4002 0400 - 0x4002 0FFF	3 KB	Reserved	
	0x4002 1000 - 0x4002 13FF	1 KB	RCC	
	0x4002 1400 - 0x4002 1FFF	3 KB	Reserved	
	0x4002 2000 - 0x4002 23FF	1 KB	Flash interface	
	0x4002 2400 - 0x4002 5FFF	15 KB	Reserved	
	0x4002 6000 - 0x4002 63FF	1 KB	Reserved	
	0x4002 6400 - 0x4002 FFFF	39 KB	Reserved	
	0x4003 0000 - 0x4003 03FF	1 KB	Reserved	
	0x4003 0400 - 0x47FF FFFF	~ 128 MB	Reserved	
	0x4800 0000 - 0x4800 03FF	1 KB	GPIOA	
	0x4800 0400 - 0x4800 07FF	1 KB	GPIOB	
	0x4800 0800 - 0x4800 0BFF	1 KB	GPIOC	
	0x4800 0C00 - 0x4800 0FFF	1 KB	GPIOD	
	0x4800 1000 - 0x5FFF FFFF	~ 384 MB	Reserved	

# 5

## Electrical characteristics

### Electrical characteristics

### 5.1 Parameter conditions

Unless otherwise specified, all voltages are referenced to  $V_{SS}$ .

#### 5.1.1 Minimum and maximum values

Unless otherwise specified, the minimum and maximum values are guaranteed with an ambient temperature at  $T_A = 25^\circ\text{C}$ ,  $V_{DD} = 3.3\text{V}$ .

#### 5.1.2 Typical values

Unless otherwise specified, typical data are based on  $T_A = 25^\circ\text{C}$  and  $V_{DD} = 3.3\text{V}$ . They are given only as design guidelines and are not tested.

#### 5.1.3 Typical curves

Unless otherwise specified, all typical curves are given only as design guidelines and are not tested.

#### 5.1.4 Loading capacitor

The load conditions used for pin parameter measurement are shown in the figure below.

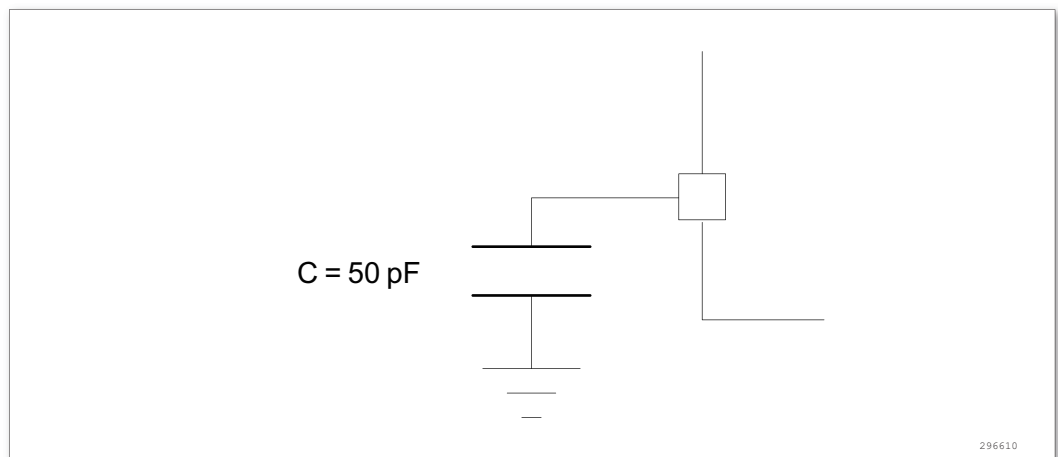

Figure 8. Pin loading conditions

### 5.1.5 Pin input voltage

The input voltage measurement on a pin of the device is shown in the figure below.

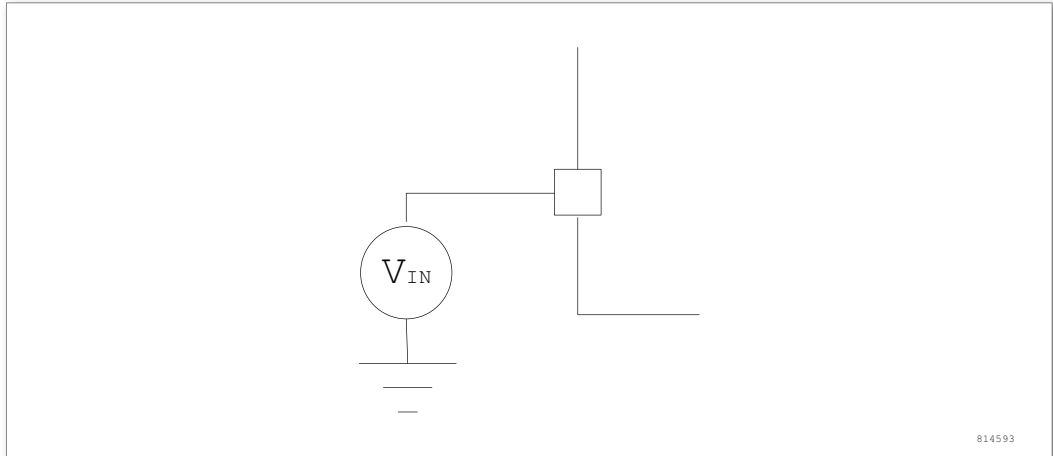

Figure 9. Pin input voltage

### 5.1.6 Power supply scheme

The power supply design scheme is shown in the figure below.

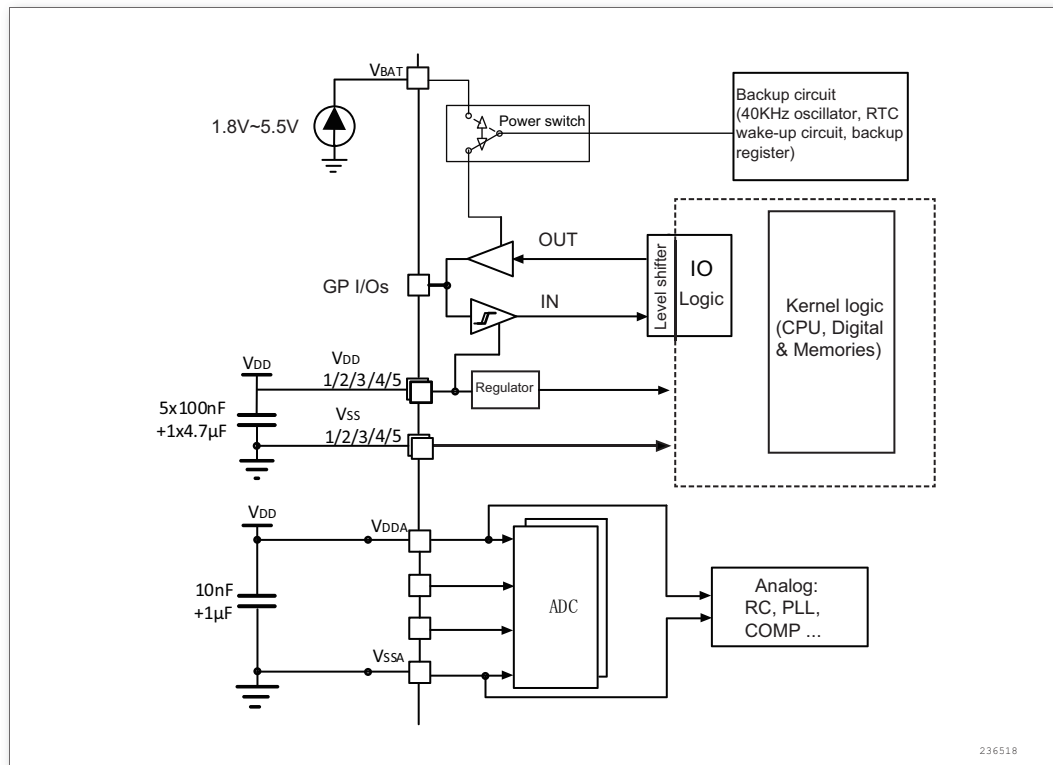

Figure 10. Power supply scheme

### 5.1.7 Current consumption measurement

The measurement of the current consumption on the pin is shown in the figure below.

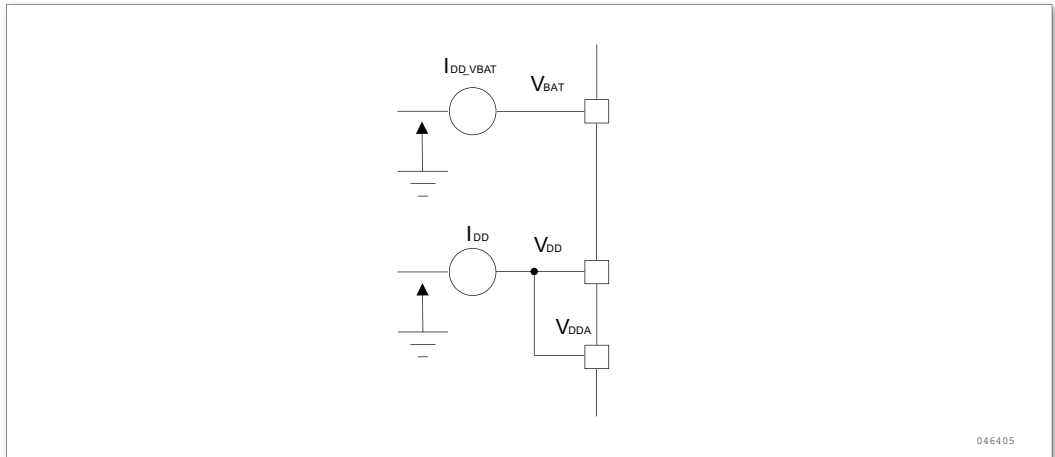

Figure 11. Current consumption measurement scheme

## 5.2 Absolute maximum ratings

Stresses above the absolute maximum ratings listed in Tables (Table 9, Table 10, Table 11) may cause permanent damage to the device. These are stress ratings only and functional operation of the device at these conditions is not implied. Exposure to maximum rating conditions for extended periods may affect device reliability.

Table 9. Voltage characteristics

Symbol	Definition	Min	Max	Unit
$V_{DD} - V_{SS}$	External main supply voltage (including $V_{DDA}$ and $V_{SSA}$ ) <sup>(1)</sup>	- 0.3	5.5	V
$V_{IN}$	Input voltage on FT and FTf pins <sup>(2)</sup>	$V_{SS} - 0.3$	5.5	
	Input voltage on other pins <sup>(2)</sup>	$V_{SS} - 0.3$	5.5	
$ \Delta V_{DDx} $	Variations between different $V_{DD}$ power pins		50	mV
$ V_{SSx} - V_{SS} $	Variations between all the different ground pins		50	

1. All main power ( $V_{DD}$ ,  $V_{DDA}$ ) and ground ( $V_{SS}$ ,  $V_{SSA}$ ) pins must always be connected to the external power supply, in the permitted range.
2.  $V_{IN}$  maximum must always be respected. Refer to Table below for maximum allowed injected current values.

Table 10. Current characteristics

Symbol	Definition	Max	Unit
$I_{VDD}$	Total current into sum of all $V_{DD}/V_{DDA}$ power lines (source) <sup>(1)</sup>	150	mA
$I_{VSS}$	Total current out of sum of all $V_{SS}$ ground lines (sink) <sup>(1)</sup>	150	mA

Symbol	Definition	Max	Unit
$I_{IO}$	Output current sunk by any I/O and control pin	20	mA
$I_{IO}$	Output current source by any I/O and control pin	-18	mA
$I_{INJ(PIN)}^{(2)(3)}$	Injected current on NRST pins	$\pm 5$	mA
$I_{INJ(PIN)}^{(2)(3)}$	Injected current on OSC_IN pin of HSE and OSC_IN pin of LSE	$\pm 5$	mA
$I_{INJ(PIN)}^{(2)(3)}$	Injected current on other pins <sup>(4)</sup>	$\pm 5$	mA
$\Sigma I_{INJ(PIN)}^{(2)}$	Total injected current(sum of all I/O and control pins) <sup>(4)</sup>	$\pm 25$	mA

1. All main power( $V_{DD}$ ,  $V_{DDA}$ ) and ground( $V_{SS}$ ,  $V_{SSA}$ ) pins must always be connected to the external power supply, in the permitted range.
2.  $I_{INJ(PIN)}$  cannot exceed its limit, that is, to ensure that the  $V_{IN}$  does not exceed its maximum value. If  $V_{IN}$  does not guarantee that its maximum value is not exceeded, ensure that  $I_{INJ(PIN)}$  does not exceed its maximum value under external restrictions. When  $V_{IN} > V_{DD}$ , there is a forward injection current; when  $V_{IN} < V_{SS}$ , there is a reverse injection current.
3. Negative injection disturbs the analog performance of the device.
4. When several inputs are submitted to a current injection, the maximum  $I_{INJ(PIN)}$  is the absolute sum of the positive and negative injected currents (instantaneous values).

Table 11. Thermal characteristics

Symbol	Definition	Max	Unit
$T_{STG}$	Storage temperature range	- 45 ~ + 150	$^{\circ}\text{C}$
$T_J$	Maximum junction temperature	125	$^{\circ}\text{C}$

## 5.3 Operating conditions

### 5.3.1 General operating conditions

Table 12. General operating conditions

Symbol	Parameter	Conditions	Min	Max	Unit
$f_{HCLK}$	Internal AHB clock frequency		0	96	MHz
$f_{PCLK1}$	Internal APB1 clock frequency		0	$f_{HCLK}$	
$f_{PCLK2}$	Internal APB2 clock frequency		0	$f_{HCLK}$	
$V_{DD}^{(1)}$	Standard operating voltage		2.0	5.5	V



Symbol	Parameter	Conditions	Min	Max	Unit
$V_{DDA}$	Analog operating voltage	Must be the same voltage as $V_{DD}$ <sup>(1)</sup>	2.5	5.5	V
$V_{BAT}$	Backup part of working voltage		1.8	5.5	V
$P_D$	Power dissipation temperature: $T_A = 85^\circ\text{C}$ <sup>(2)</sup>	LQFP64		203	mW
		LQFP48			
		LQFP32/QFN32			
$T_A$	Ambient temperature: $T_A = 85^\circ\text{C}$	Maximum power dissipation	-40	85	$^\circ\text{C}$
		Low power dissipation <sup>(3)</sup>	-40	105	
	Ambient temperature: $T_A = 105^\circ\text{C}$	Maximum power dissipation	-40	105	$^\circ\text{C}$
		Low power dissipation <sup>(3)</sup>	-40	125	

1. It is recommended to use the same power supply for  $V_{DD}$  and  $V_{DDA}$ , the maximum permissible difference between  $V_{DD}$  and  $V_{DDA}$  is 300mV during power up and normal operation.
2. If  $T_A$  is low, higher  $P_D$  values are allowed as long as  $T_J$  does not exceed  $T_{Jmax}$  (See subsec 5.1).
3. In low power dissipation state,  $T_A$  can be extended to this range as long as  $T_J$  does not exceed  $T_{Jmax}$  (See subsec 5.1).

### 5.3.2 Operating conditions at power-up/power-down

The parameters given in the table below are based on tests under normal operating conditions.

Table 13. Operating conditions at power-up/power-down

Symbol	Parameter	Conditions	Min	Max	Unit
$t_{VDD}$	$V_{VDD}$ rise time rate	$T_A = 27^\circ\text{C}$	100	$\infty$	$\mu\text{S/V}$
	$V_{VDD}$ fall time rate		100	$\infty$	

### 5.3.3 Embedded reset and power control block characteristics

The parameters given in the table below are based on the ambient temperature and the  $V_{DD}$  supply voltage listed in Table 12.

Table 14. Embedded reset and power control block characteristics

Symbol	Parameter	Conditions	Min	Typ	Max	Unit
		PLS[3: 0]=0000 (Rising edge)	1.813	1.819	1.831	V
		PLS[3: 0]=0000 (Falling edge)		1.705		V
		PLS[3: 0]=0001 (Rising edge)	2.112	2.116	2.124	V
		PLS[3: 0]=0001 (Falling edge)		2.0		V

Symbol	Parameter	Conditions	Min	Typ	Max	Unit
		PLS[3: 0]=0010 (Rising edge)	2.411	2.414	2.421	V
		PLS[3: 0]=0010 (Falling edge)		2.297		V
		PLS[3: 0]=0011 (Rising edge)	2.711	2.714	2.719	V
		PLS[3: 0]=0011 (Falling edge)		2.597		V
		PLS[3: 0]=0100 (Rising edge)	3.011	3.013	3.018	V
		PLS[3: 0]=0100 (Falling edge)		2.895		V
		PLS[3: 0]=0101 (Rising edge)	3.311	3.313	3.317	V
		PLS[3: 0]=0101 (Falling edge)		3.194		V
		PLS[3: 0]=0110 (Rising edge)	3.611	3.613	3.616	V
		PLS[3: 0]=0110 (Falling edge)		3.494		V
		PLS[3: 0]=0111 (Rising edge)	3.91	3.913	3.916	V
		PLS[3: 0]=0111 (Falling edge)		3.793		V
		PLS[3: 0]=1000 (Rising edge)	4.21	4.212	4.215	V
		PLS[3: 0]=1000 (Falling edge)		4.092		V
		PLS[3: 0]=1001 (Rising edge)	4.51	4.512	4.515	V
		PLS[3: 0]=1001 (Falling edge)		4.391		V
		PLS[3: 0]=1010 (Rising edge)	4.809	4.811	4.813	V
		PLS[3: 0]=1010 (Falling edge)		4.69		V
$V_{PVDhyst}^{(2)}$	PVD hysteresis			100		mV
$V_{POR/PDR}$	Power on/down reset threshold	Falling edge	1.63 <sup>(1)</sup>	1.66	1.68	V
		Rising edge		1.75		V
$V_{PDRhys}^{(2)}$	PDR hysteresis			90.9		mV
$T_{RSTTEMPO}^{(2)}$	Reset duration			20		ms

1. The product behavior is guaranteed by design down to the minimum value  $V_{POR/PDR}$ .
2. Guaranteed by design, not tested in production.

*Note: The reset duration is measured from power-on (POR reset) to the time when the user application code reads the first instruction.*

### 5.3.4 Embedded internal reference voltage

The parameters given in the table below are based on the ambient temperature and the  $V_{DD}$  supply voltage listed in Table 12.

Table 15. Embedded internal reference voltage<sup>(1)</sup>

Symbol	Parameter	Conditions	Min	Typ	Max	Unit
$V_{REFINT}$	Internal reference voltage	$-40^{\circ}\text{C} < T_A < +105^{\circ}\text{C}$		1.2		V
		$-40^{\circ}\text{C} < T_A < +85^{\circ}\text{C}$		1.2		V

Symbol	Parameter	Conditions	Min	Typ	Max	Unit
$T_{S\_vrefint}^{(1)}$	ADC sampling time when reading the internal reference voltage	0				$\mu S$

1. Shortest sampling time can be determined in the application by multiple iterations.

### 5.3.5 Supply current characteristics

The current consumption is a function of several parameters and factors such as the operating voltage, temperature, I/O pin loading, device software configuration, operating frequencies, I/O pin switching rate, program location in memory and executed binary code.

All Run-mode current consumption measurements given in this section are performed with a reduced code.

#### Maximum current consumption

The MCU is placed under the following conditions:

- All I/O pins are in analog input mode, and are connected to a static level —  $V_{DD}$  or  $V_{SS}$  (no load)
- All peripherals are disabled except when explicitly mentioned
- The Flash memory access time is adjusted to the  $f_{HCLK}$  (0 ~ 24 MHz is 0 waiting period , 24 ~ 48 MHz is 1 waiting period, 48 ~ 72 MHz is 2 waiting period, 72 ~ 96 MHz is 3 waiting period ).
- The instruction prefetching function is on. When the peripherals are enabled:  
 $f_{PCLK1} = f_{HCLK}$ .

*Note: The instruction prefetching function must be set before setting the clock and bus divider.*

The parameters given in the table (Table 16、Table 17、Table 18) are based on the ambient temperature and the  $V_{DD}$  supply voltage listed in Table 12 .

Table 16. Typical current consumption in Run mode, code executing from Flash memory

Symbol	Parameter	Conditions	$f_{HCLK}$	Typ <sup>(1)</sup>		Unit
				All peripherals enabled <sup>(2)</sup>	All peripherals disabled	
$I_{DD}$	Supply current in run mode	External clock <sup>(2)</sup>	96MHz	26.23	15.2	mA
			72MHz	20.52	12.19	
			48MHz	14.71	9.13	
			36MHz	11.76	7.58	
			24MHz	8.84	6.03	
$I_{DD}$	Supply current in run mode	External clock <sup>(2)</sup>	8MHz	4.1	3.14	

1. The typical value is tested at  $T_A = 25^\circ\text{C}$ . Guaranteed by design, not tested in production.
2. External clock is 8MHz, when  $f_{\text{HCLK}} > 8\text{MHz}$  enable PLL.

Table 17. Typical current consumption in Sleep mode, code executing from Flash memory or RAM

Symbol	Parameter	Conditions	$f_{\text{HCLK}}$	Typ <sup>(1)</sup>		Unit
				All peripherals enabled <sup>(2)</sup>	All peripherals disabled	
$I_{\text{DD}}$	Supply current in Sleep mode	External clock <sup>(2)</sup>	96MHz	22.41	10.92	mA
			72MHz	17.57	8.96	
			48MHz	12.68	6.96	
			36MHz	10.29	5.95	
			24MHz	7.79	4.9	
			8MHz	3.46	2.8	

1. The typical value is tested at  $T_A = 25^\circ\text{C}$ . From a comprehensive evaluation, it is tested in terms of  $V_{\text{DDmax}}$  and  $f_{\text{HCLKmax}}$  enable peripherals in production.
2. External clock is 8MHz, when  $f_{\text{HCLK}} > 8\text{MHz}$  enable PLL.

Table 18. Maximum current consumption in Stop and Standby mode, code executing from Flash memory

Symbol	Parameter	Conditions	Max	Unit
			$T_A = 25^\circ\text{C}$	
$I_{\text{DD}}$	Supply current in Stop mode	Enter the stop mode after reset, $V_{\text{DD}} = 3.3\text{V}$	402	$\mu\text{A}$
	Supply current in Standby mode	Enter the standby mode after reset, $V_{\text{DD}} = 3.3\text{V}$	0.4	
$I_{\text{DD\_VBAT}}$	Supply current in the backup area	Low speed oscillator and RTC are on, $V_{\text{DD}}/V_{\text{BAT}} = 3.3\text{V}$	0.2	$\mu\text{A}$

1. I/O status is analog input.

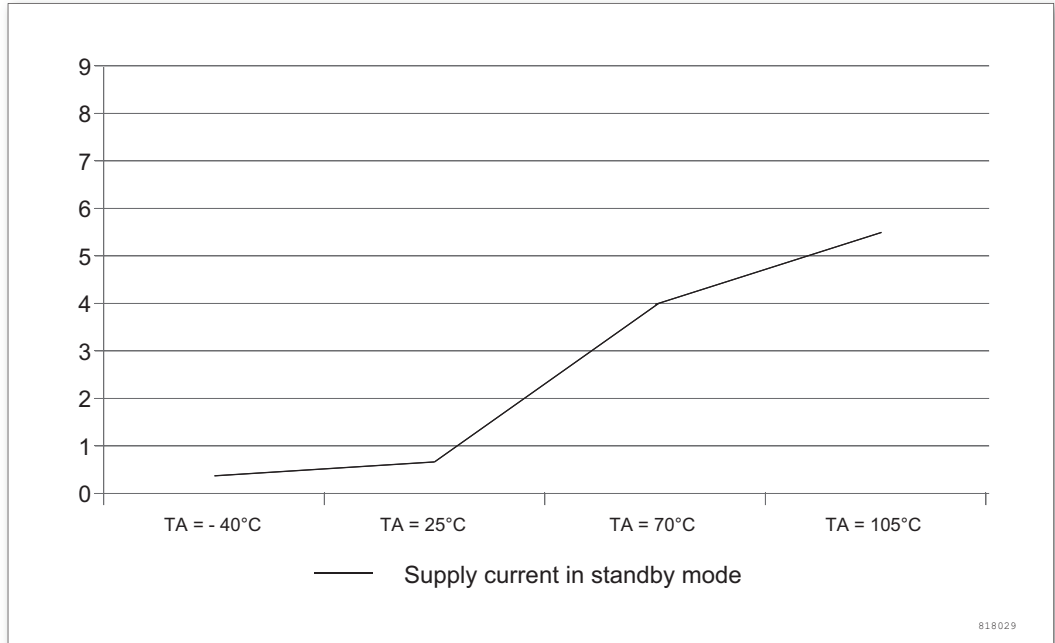

Figure 12. Typical current consumption in standby mode vs. temperature at V<sub>DD</sub> = 3.3V

### Typical current consumption

The MCU is placed under the following conditions:

- All I/O pins are in analog input configuration, and are connected to a static level — V<sub>DD</sub> or V<sub>SS</sub> (no load).
- All the peripherals are closed, unless otherwise specified.
- The Flash memory access time is adjusted to the f<sub>HCLK</sub> (0 ~ 24 MHz is 0 waiting period ,24 ~ 48 MHz is 1 waiting period, 48 ~ 72 MHz is 2 waiting period, 72 ~ 96 MHz is 3 waiting period ).
- The ambient temperature and V<sub>DD</sub> supply voltage conditions are summarized in Table 12.
- The instruction prefetching function is on. When the peripherals are enabled:  
 $f_{PCLK1} = f_{HCLK}$ .

*Note: The instruction prefetch function must be set before the clock is set and the bus is divided.*

### On-chip peripheral current consumption

The current consumption of the on-chip peripherals is given in Table 19. The MCU is placed under the following conditions:

- All I/O pins are in analog input mode, and are connected to a static level — V<sub>DD</sub> or V<sub>SS</sub> (no load) .
- All peripherals are disabled except when explicitly mentioned.
- The given value is calculated by measuring the current consumption.
  - with all peripherals clocked OFF
  - with only one peripheral clocked on

- Ambient operating temperature and supply voltage conditions  $V_{DD}$  summarized in Table 12.

Table 19. On-chip peripheral current consumption<sup>(1)</sup>

Peripheral		Typical consumption at 25 °C	Unit	Peripheral		Typical consumption at 25 °C	Unit
APB1	TIM2	0.098	mA	APB2	GPIOA	0.045	mA
	TIM3	0.062			GPIOB	0.046	
APB1	TIM4	0.055	mA	APB2	GPIOC	0.052	mA
	SPI2	0.133			GIOD	0.046	
	UART2	0.077			ADC1	0.051	
	UART3	0.078			ADC2	0.052	
	I2C1	0.132			TIM1	0.121	
	I2C2	0.134			SPI1	0.122	
	USB	0.058			UART1	0.078	
	CAN	0.033					

1.  $f_{HCLK} = 96\text{MHz}$ ,  $f_{APB1} = f_{HCLK}/2$ ,  $f_{APB2} = f_{HCLK}$ , the prescale coefficient for each device is the default value.

### 5.3.6 External clock source characteristics

#### High-speed external user clock generated from an external source

The characteristic parameters given in the following table are measured using a high-speed external clock source, ambient temperature and power supply voltage meet the conditions of General operating conditions.

Table 20. High-speed external user clock characteristics

Symbol	Parameter	Conditions	Min	Typ	Max	Unit
$f_{HSE\_ext}$	User external clock source frequency <sup>(1)</sup>		2	8	24	MHz
$V_{HSEH}$	OSC_IN input pin high level voltage		$0.7V_{DD}$		$V_{DD}$	V
$V_{HSEL}$	OSC_IN input pin low level voltage		$V_{SS}$		$0.3V_{DD}$	
$t_{w(HSE)}$	OSC_IN high or low time <sup>(1)</sup>		16			nS
$t_{r(HSE)}$ $t_{f(HSE)}$	OSC_IN rise or fall time <sup>(1)</sup>				20	
$C_{in(HSE)}$	OSC_IN input capacitance <sup>(1)</sup>			5		pF
$DuCy_{(HSE)}$	Duty cycle		45		55	%
$I_L$	OSC_IN input leakage current	$V_{SS} \leq V_{IN} \leq V_{DD}$			$\pm 1$	$\mu\text{A}$

1. Guaranteed by design, not tested in production.

### Low-speed external user clock characteristics

The characteristic parameters given in the following table are measured using a low-speed external clock source, ambient temperature and power supply voltage meet the conditions of General operating conditions.

Table 21. Low-speed external user clock characteristics

Symbol	Parameter	Conditions	Min	Typ	Max	Unit
$f_{LSE\_ext}$	User external clock source frequency <sup>(1)</sup>		16	32.768	200	KHz
$V_{LSEH}$	OSC_IN input pin high level voltage				1.2	V
$V_{LSEL}$	OSC_IN input pin low level voltage		0.25			V
$t_{w(LSE)}$	OSC_IN high or low time <sup>(1)</sup>			15259		nS
$t_{r(LSE)}$	OSC_IN rise time <sup>(1)</sup>			30		nS
$t_{f(LSE)}$	OSC_IN fall time <sup>(1)</sup>			30		nS
$C_{in(LSE)}$	OSC_IN input capacitance <sup>(1)</sup>			5		pF
$DuCy_{(LSE)}$	Duty cycle			50		%
$I_L$	OSC_IN input leakage current	$V_{SS} \leq V_{IN} \leq V_{DD}$		0.03		uA

1. Guaranteed by design, not tested in production.

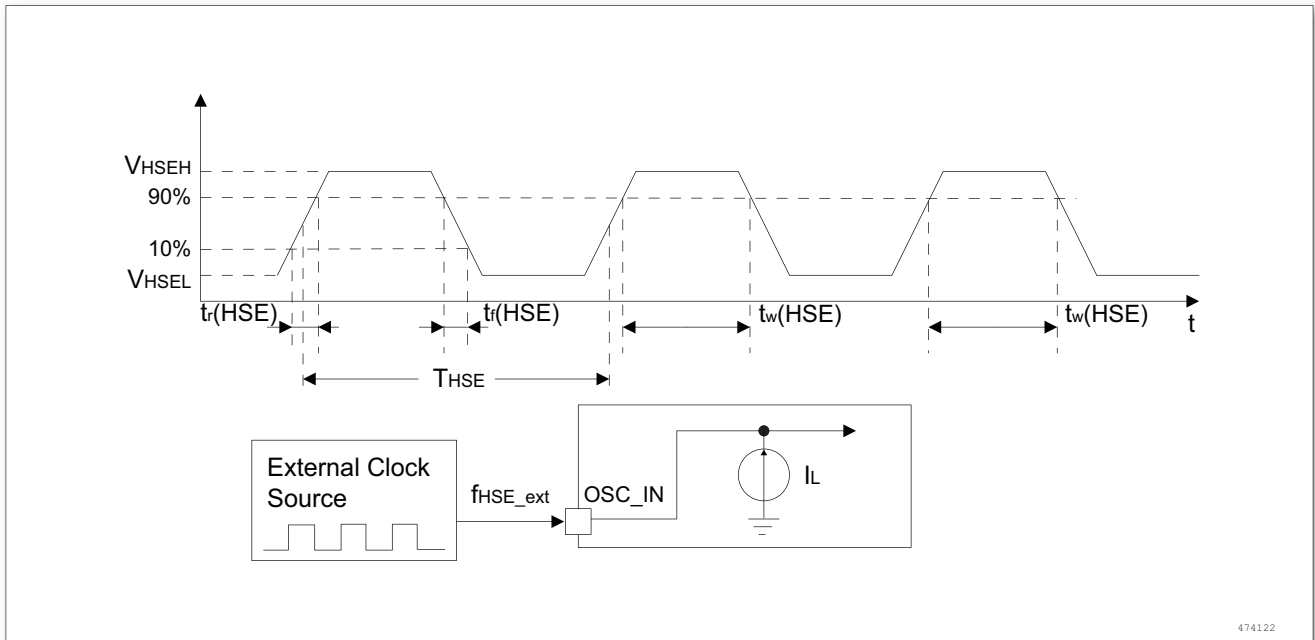

Figure 13. High-speed external clock source AC timing diagram

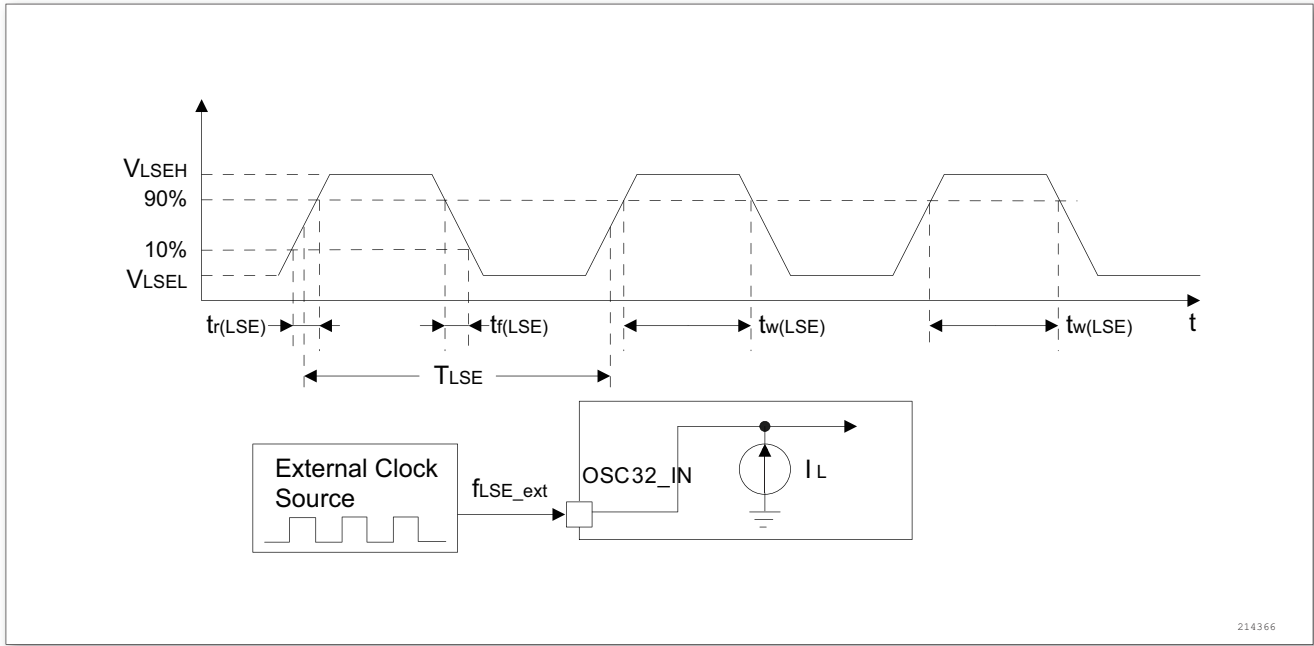

Figure 14. Low-speed external clock source AC timing diagram

### High-speed external clock generated from a crystal/ceramic resonator

The high-speed external (HSE) clock can be supplied with an 2 to 24 MHz crystal/ceramic resonator oscillator. All the information given in this paragraph are based on design simulation results obtained with typical external components specified in the table below. In the application, the resonator and the load capacitors have to be placed as close as possible to the oscillator pins in order to minimize output distortion and startup stabilization time. Refer to the crystal resonator manufacturer for more details on the resonator characteristics (frequency, package, accuracy...).

Table 22. HSE oscillator characteristics<sup>(1)(2)</sup>

Symbol	Parameter	Conditions	Min	Typ	Max	Unit
$f_{OSC\_IN}$	Oscillator frequency		2	8	24	MHz
$R_F$	Feedback resistor	$R_S = 30\Omega$		1000		k $\Omega$
$C_{L1}$ $C_{L2}^{(3)}$	The proposed load capacitance corresponds to the crystal serial impedance ( $R_S$ ) <sup>(4)</sup>	$V_{DD} = 3.3V$ $V_{IN} = V_{SS}$ 30pF load		30		pF
$I_2$	HSE current consumption	Startup			1	mA
$g_m$	Oscillator transconductance	$V_{DD}$ is stabilized	25			mA/V
$t_{SU(HSE)}^{(5)}$	Startup time	$R_S = 30\Omega$		2		mS

1. Resonator characteristics given by the crystal/ceramic resonator manufacturer characteristics Parameter.



2. Guaranteed by design, not tested in production.
3. For  $C_{L1}$  and  $C_{L2}$ , it is recommended to use high-quality external ceramic capacitors in the 5 pF to 25 pF range (Typ.) , designed for high-frequency applications, and selected to match the requirements of the crystal or resonator.  $C_{L1}$  and  $C_{L2}$  are usually the same size. The crystal manufacturer typically specifies a load capacitance which is the series combination of  $C_{L1}$  and  $C_{L2}$ . PCB and MCU pin capacitance must be included (10 pF can be used as a rough estimate of the combined pin and board capacitance) when sizing  $C_{L1}$  and  $C_{L2}$ .
4. The relatively low value of the RF resistance can be used to avoid problems arising from the use of wet conditions to provide protection, this environment resulting in leakage and bias conditions have changed. However, if the MCU is applied in bad wet conditions, the design needs to take this parameter into account.
5.  $t_{SU(HSE)}$  is the startup time measured from the moment it is enabled (by software) to a stabilized 8 MHz oscillation is reached. This value is measured for a standard crystal resonator and it can vary significantly with the crystal manufacturer.

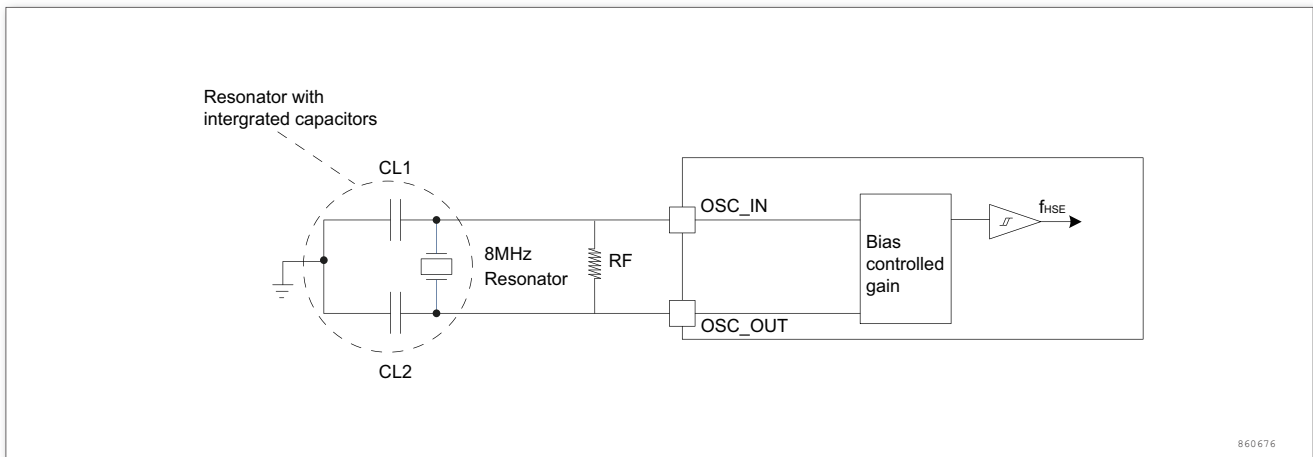

Figure 15. Typical application with an 8 MHz crystal

### Low-speed external clock generated from a crystal/ceramic resonator

The low-speed external (LSE) clock can be supplied with a 32.768 kHz crystal/ceramic resonator oscillator. All the information given in this paragraph are based on characterization results obtained with typical external components specified in the table below. In the application, the resonator and the load capacitors have to be placed as close as possible to the oscillator pins in order to minimize output distortion and startup stabilization time. Refer to the crystal resonator manufacturer for more details on the resonator characteristics (frequency, package, accuracy). Note: For  $C_{L1}$  and  $C_{L2}$ , it is recommended to use a high quality ceramic capacitor between 5pF and 15pF and select the crystal or resonator that meets the requirements. Usually  $C_{L1}$  and  $C_{L2}$  have the same parameters. Crystal manufacturers typically give the parameters of the load capacitance in a serial combination of  $C_{L1}$  and  $C_{L2}$ . The load capacitance  $C_L$  is calculated by:  $C_L = C_{L1} \times C_{L2} / (C_{L1} + C_{L2}) + C_{stray}$ , where  $C_{stray}$  is the capacitance of the pin and the capacitance associated with the PCB or PCB. Its typical value is between 2pF and 7pF. **WARNING:** To avoid exceeding

the maximum value of  $C_{L1}$  and  $C_{L2}$  (15pF) , it is highly recommended to use a resonator with a load capacitance of  $C_L \leq 7\text{pF}$ . A resonator with a load capacitance of 12.5pF cannot be used. For example, if a resonator with a load capacitance of  $C_L = 6\text{pF}$  is selected and  $C_{\text{stray}} = 2\text{pF}$ , then  $C_{L1} = C_{L2} = 8\text{pF}$ .

Table 23. LSI oscillator characteristics ( $f_{\text{LSE}}=32.768\text{KHz}$ ) <sup>(1)</sup>

Symbol	Parameter	Conditions	Min	Typ	Max	Unit
$R_F$	Feedback resistor			25		$M\Omega$
$C_{L1}$ $C_{L2}$ <sup>(2)</sup>	The proposed load capacitance corresponds to the crystal serial impedance ( $R_S$ ) <sup>(3)</sup>	$R_S = 30\Omega$			4	pF
$I_2$	LSE current consumption	$V_{DD} = 3.3V$ $V_{IN} = V_{SS}$		0.08		$\mu A$
$g_m$	Oscillator transconductance			0.5		$\mu A/V$
$t_{\text{SU(HSE)}}^{(4)}$	Startup time	$V_{DD}$ is stabilized		1	4	S

1. Guaranteed by design, not tested in production.
2. See the note and warning paragraphs above this table.
3. Selecting a high quality oscillator with a small  $R_S$  value (such as MSIV-TIN 32.768KHz) optimizes current consumption. Please consult the crystal manufacturer for details.
4.  $t_{\text{SU(HSE)}}$  is the start-up time, which is measured from the time the software enables HSE until a stable 8MHz oscillation is obtained. This value is measured on a standard crystal resonator, which may vary greatly depending on the crystal manufacturer.

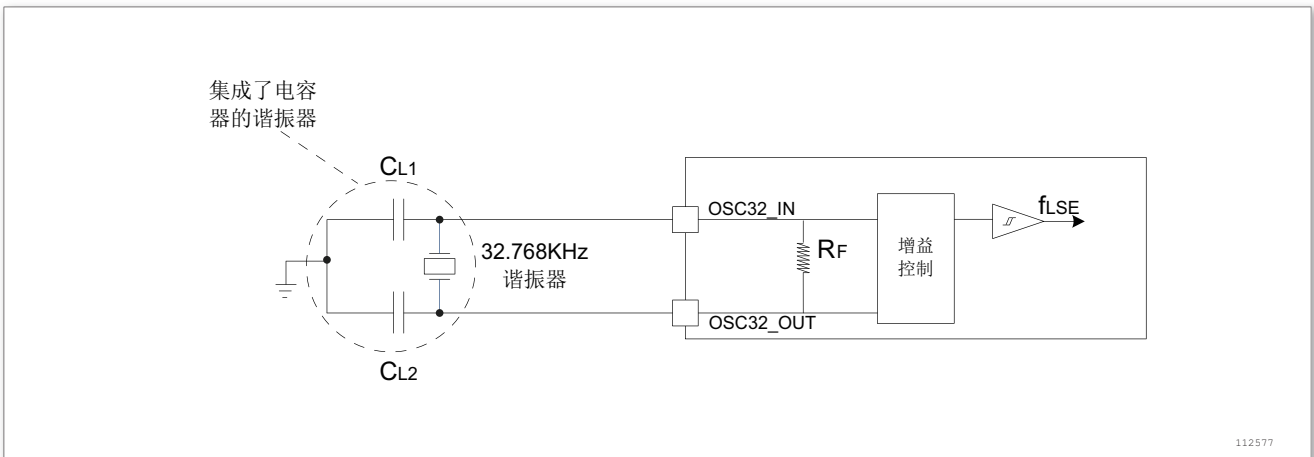

Figure 16. Typical application with a 32.768 kHz crystal

### 5.3.7 Internal clock source characteristics

The characteristic parameters given in the table below are measured using ambient temperature and supply voltage in accordance with general operating conditions.

#### High-speed internal (HSI) oscillator

Table 24. HSI oscillator characteristics<sup>(1)(2)</sup>

Symbol	Parameter	Conditions	Min	Typ	Max	Unit
$f_{\text{HSI}}$	Frequency		40	48	64	MHz
$\text{ACC}_{\text{HSI}}$	Accuracy of the HSI oscillator	$T_A = -40^\circ\text{C} \sim 105^\circ\text{C}$	-5		5	%
$\text{ACC}_{\text{HSI}}$	Accuracy of the HSI oscillator	$T_A = -10^\circ\text{C} \sim 85^\circ\text{C}$	-3		3	%
$\text{ACC}_{\text{HSI}}$	Accuracy of the HSI oscillator	$T_A = 0^\circ\text{C} \sim 70^\circ\text{C}$	-2		2	%
$\text{ACC}_{\text{HSI}}$	Accuracy of the HSI oscillator	$T_A = 25$	-1		1	%
$t_{\text{SU(HSI)}}$	HSI oscillator startup time				2	$\mu\text{S}$
$I_{\text{DD(HSI)}}$	HSI oscillator power consumption			81	200	$\mu\text{A}$

1.  $V_{\text{DD}} = 3.3\text{V}$ ,  $T_A = -40^\circ\text{C} \sim 105^\circ\text{C}$ , unless otherwise specified.
2. Guaranteed by design, not tested in production.

### Low-speed internal (LSI) oscillator

Table 25. LSI oscillator characteristics<sup>(1)</sup>

Symbol	Parameter	Conditions	Min	Typ	Max	Unit
$f_{\text{LSI}}^{(2)}$	Frequency		31	40	75	KHz
$t_{\text{SU(LSI)}}^{(2)}$	LSI oscillator startup time				1	$\mu\text{S}$
$I_{\text{DD(LSI)}}^{(3)}$	LSI oscillator power consumption			1.1	1.7	$\mu\text{A}$

1.  $V_{\text{DD}} = 3.3\text{V}$ ,  $T_A = -40^\circ\text{C} \sim 105^\circ\text{C}$ , Unless otherwise stated
2. Comprehensive assessment, not tested in production.
3. Guaranteed by design, not tested in production.

### Wake-up times from low power mode

The wake-up times listed in the table below are measured during the wake-up phase of the internal clock HSI. The clock source used when waking up depends on the current operating mode:

- Stop or Standby mode: The clock source is the oscillator
- Sleep mode: The clock source is the clock used when entering sleep mode

All times are measured using ambient temperature and supply voltage in accordance with common operating conditions.

Table 26. Low-power mode wakeup timings

Symbol	Parameter	Conditions	Max	Unit
$t_{WUSLEEP}^{(1)}$	Wakeup from Sleep mode	HSI clock wakeup	4.2	$\mu\text{S}$
$t_{WUSTOP}^{(1)}$	Wakeup from Stop mode (The regulator is in run mode)	HSI clock wakeup = $2\mu\text{S}$	6.3	
$t_{WUSTDBY}^{(1)}$	Wakeup from Standby mode	HSI clock wakeup = $2\mu\text{S}$ The regulator wakes up from the off mode = $38\mu\text{S}$	47	mS

1. The wake-up time is measured from the start of the wake-up event to the user program to read the first instruction.

### 5.3.8 PLL characteristics

The parameters listed in the table below are measured using ambient temperature and supply voltage in accordance with common operating conditions.

Table 27. PLL characteristics<sup>(1)</sup>

Symbol	Parameter	Min	Typ	Max	Unit
$f_{PLL\_IN}$	PLL input clock <sup>(2)</sup>	2		24	MHz
	PLL input clock duty cycle	40		60	%
$f_{PLL\_OUT}$	PLL multiplier output clock	40		200	MHz
$t_{LOCK}$	PLL lock time			100	$\mu\text{S}$

1. Guaranteed by design, not tested in production.
2. Take care to use the appropriate multiplier factors to obtain PLL input clock values compatible with the range defined by  $f_{PLL\_OUT}$ .

### 5.3.9 Memory characteristics

#### Flash memory

The characteristics are given at  $T_A = -40^\circ\text{C} \sim 105^\circ\text{C}$  unless otherwise specified.

Table 28. Flash memory characteristics

Symbol	Parameter	Conditions	Min	Typ	Max	Unit
$t_{prog}$	8-bit programming time	$T_A = -40^\circ\text{C} \sim 125^\circ\text{C}$	4			$\mu\text{S}$

Symbol	Parameter	Conditions	Min	Typ	Max	Unit
$t_{ERASE}$	Page (512K bytes) erase time	$T_A = -40^{\circ}\text{C} \sim 125^{\circ}\text{C}$		4	5	mS
$t_{ME}$	Mass erase time	$T_A = -40^{\circ}\text{C} \sim 125^{\circ}\text{C}$	20		40	mS
$I_{DD}$	Supply current	Read mode, $f_{HCLK} = 48\text{MHz}$		5	6	mA
		Write mode, $f_{HCLK} = 48\text{MHz}$			7	mA
		Erase mode, $f_{HCLK} = 48\text{MHz}$			2	mA
$I_{SB}$	Standby current			1@25°C	50@125°C	μA
$I_{DEP}$	Deep Standby current			0.5	15@125°C	μA

Table 29. Flash memory endurance and data retention<sup>(1)(2)</sup>

Symbol	Parameter	Conditions	Min	Typ	Max	Unit
NEND	Endurance (Annotation: Erase number of times)	$T_A = -40^{\circ}\text{C} \sim 85^{\circ}\text{C}$	10			K cycle
		$T_A = -40^{\circ}\text{C} \sim 105^{\circ}\text{C}$				
$t_{RET}$	Data retention	1 K cycle <sup>(2)</sup> at $T_A = 85^{\circ}\text{C}$	30			Year
		1 K cycle <sup>(1)(2)</sup> at $T_A = 105^{\circ}\text{C}$	10			
		10 K cycle <sup>(1)(2)</sup> at $T_A = 55^{\circ}\text{C}$	20			

1. Guaranteed by design, not tested in production.
2. Cycle tests are carried out in the whole temperature range.

### 5.3.10 EMC characteristics

Susceptibility tests are performed on a sample basis during device characterization.

#### Functional EMS (electromagnetic susceptibility)

While a simple application is executed on the device (toggling 2 LEDs through I/O ports), the device is stressed by two electromagnetic events until a failure occurs. The failure is indicated by the LEDs:

- Electrostatic discharge (ESD) (positive and negative) is applied to all device pins until a functional disturbance occurs. This test is compliant with the IEC 61000-4-2 standard.
- FTB: A Burst of Fast Transient voltage (positive and negative) is applied to VDD and VSS through a 100 pF capacitor, until a functional disturbance occurs. This test is

compliant with the IEC 1000-4-4 standard.

A device reset allows normal operations to be resumed.

The test results are given in the following table. They are based on the EMS levels and classes defined in application note.

Table 30. EMS characteristics

Symbol	Parameter	Conditions	Level/Class
$V_{EFT}$	Fast transient voltage burst limits to be applied through 100 pF on $V_{DD}$ and $V_{SS}$ pins to induce a functional disturbance	$V_{DD} = 3.3V, T_A = +25^\circ C,$ $f_{HCLK} = 48MHz.$ Conforming to IEC 1000-4-4	TBD

## Designing hardened software to avoid noise problems

EMC characterization and optimization are performed at component level with a typical application environment and simplified MCU software. It should be noted that good EMC performance is highly dependent on the user application and the software in particular.

Therefore it is recommended that the user applies EMC software optimization and pre-qualification tests in relation with the EMC level requested for his application.

## Software recommendations

The software flowchart must include the management of runaway conditions such as:

- Corrupted program counter
- Unexpected reset
- Critical Data corruption (for example control registers)

## Prequalification trials

Most of the common failures (unexpected reset and program counter corruption) can be reproduced by manually forcing a low state on the NRST pin or the Oscillator pins for 1 second.

To complete these trials, ESD stress can be applied directly on the device, over the range of specification values. When unexpected behavior is detected, the software can be hardened to prevent unrecoverable errors.

### 5.3.11 Absolute Maximum (Electrical Sensitivity)

Based on three different tests (ESD, LU) using specific measurement methods, the device is stressed in order to determine its performance in terms of electrical sensitivity.

## Electrostatic discharge (ESD)

Electrostatic discharges (a positive then a negative pulse separated by 1 second) are applied to the pins of each sample according to each pin combination. The sample size depends on the number of supply pins in the device (3 parts × (n+1) supply pins). This test conforms to the JESD22-A114/C101 standard.

## Static latch-up

Two complementary static tests are required on six parts to assess the latch-up performance:

- A supply overvoltage is applied to each power supply pin
- A current injection is applied to each input, output and configurable I/O pin

These tests are compliant with EIA/JESD78A IC latch-up standard.

Table 31. ESD characteristics

Symbol	Parameter	Conditions	Type	Max	Unit
$V_{ESD(HBM)}$	Electrostatic discharge voltage (Human body model)	$T_A = +25^\circ\text{C}$ , Conforming to JESD22-A114		2000	V
$V_{ESD(CDM)}$	Electrostatic discharge voltage (Charging device model)	$T_A = +25^\circ\text{C}$ , Conforming to JESD22-C101		500	
$I_{LU}$	Latch-up current	$T_A =$ $+25^\circ\text{C}$ , Conforming to JESD78A		200	mA

## 5.3.12 I/O port characteristics

### General input/output characteristics

Unless otherwise specified, the parameters given in Table 9 are derived from tests.

Table 32. I/O static characteristics

Symbol	Parameter	Conditions	Min	Typ	Max	Unit
$V_{IL}$	Low level input voltage	CMOS Port	-0.5		1.1	V
$V_{IH}$	High level input voltage	CMOS Port	2.08			V
$V_{hys}$	Schmitt trigger hysteresis <sup>(1)</sup>		500	700	800	mV
$I_{lkg}$	Input leakage current <sup>(2)</sup>				1	$\mu\text{A}$
$R_{PU}$	Weak pull-up equivalent resistor <sup>(3)</sup>	$V_{IN} = V_{SS}$	30	50	100	k $\Omega$
$R_{PD}$	Weak pull-down equivalent resistor <sup>(3)</sup>	$V_{IN} = V_{DD}$	30	50	100	

Symbol	Parameter	Conditions	Min	Typ	Max	Unit
C <sub>IO</sub>	I/O pin capacitance				5	pF

- Schmitt Trigger switching hysteresis voltage level. Data based on design simulation only. Not tested in production.
- The leakage could be higher than the maximum value, if negative current is injected on adjacent pins.
- Pull-up and pull-down resistors are designed with a true resistance in series with a switchable PMOS/NMOS. This PMOS/NMOS contribution to the series resistance is minimal (10% order).

All I/Os are CMOS (no software configuration required). Their characteristics cover more than the strict CMOS-technology.

- For V<sub>IH</sub>:
  - If V<sub>DD</sub> is between [2.50V~ 3.08V]; use CMOS features.
  - If V<sub>DD</sub> is between [3.08V~ 3.60V]; include CMOS.
- For V<sub>IL</sub>:
  - Use CMOS features.

### Output driving current

The GPIOs (general purpose input/outputs) can sink or source up to ±20mA.

In the user application, the number of I/O pins which can drive current must be limited to respect the absolute maximum rating specified in 5.2:

- The sum of the currents obtained from V<sub>DD</sub> for all I/O ports, plus the maximum operating current that the MCU obtains on V<sub>DD</sub>, cannot exceed the absolute maximum rating I<sub>VDD</sub>.
- The sum of the currents drawn by all I/O ports and flowing out of V<sub>SS</sub>, plus the maximum operating current of the MCU flowing out on V<sub>SS</sub>, cannot exceed the absolute maximum rating I<sub>VSS</sub>.

### Output voltage levels

Unless otherwise stated, the parameters listed in the table below are measured using the ambient temperature and V<sub>DD</sub> supply voltage in accordance with the condition Table 9. All I/O ports are CMOS compatible.

Table 33. Output voltage characteristics

Symbol	Parameter	Conditions	Min	Max	Unit
V <sub>OL</sub> <sup>(1)</sup>	Output low level voltage for an I/O pin, when 8 pins absorb current	CMOS Port, I <sub>IO</sub> = +8mA 2.7V < V <sub>DD</sub> < 3.6V		0.4	



Symbol	Parameter	Conditions	Min	Max	Unit
$V_{OH}^{(2)}$	Output high level voltage for an I/O pin, when 8 pins output current	CMOS Port, $I_{IO} = +8mA$ $2.7V < V_{DD} < 3.6V$	$0.8V_{DD}$		V
$V_{OL}^{(1)(3)}$	Output low level voltage for an I/O pin, when 8 pins absorb current	$I_{IO} = +20mA$ $2.7V < V_{DD} < 3.6V$		0.4	
$V_{OH}^{(2)(3)}$	Output high level voltage for an I/O pin, when 8 pins output current		$0.8V_{DD}$		
$V_{OL}^{(2)(3)}$	Output low level voltage for an I/O pin, when 8 pins absorb current	$I_{IO} = +6mA$ $2V < V_{DD} < 2.7V$		TBD	
$V_{OH}^{(2)(3)}$	Output high level voltage for an I/O pin, when 8 pins output current	$I_{IO} = +6mA$ $2V < V_{DD} < 2.7V$	TBD		

1. The current absorbed by the chip  $I_{IO}$  must always follow the absolute maximum ratings given in the table, and the sum of  $I_{IO}$  (all I/O feet and control pins) must not exceed  $I_{VSS}$ .
2. The current output  $I_{IO}$  of the chip must always follow the absolute maximum rating given in the table, and the sum of  $I_{IO}$  (all I/O pins and control pins) must not exceed  $I_{VDD}$ .
3. Data based on characterization results. Not tested in production.

### Input/output AC characteristics

The definitions and values of the input and output AC characteristics are given in figure 17 and Table 34, respectively.

Unless otherwise stated, the parameters listed in Table 34 are measured using the ambient temperature and supply voltage in accordance with the condition Table 9.

Table 34. I/O AC characteristics<sup>(1)</sup>

OSPEEDRy [1:0] value (1)	Symbol	Parameter	Conditions	Min	Max	Unit
01 (10MHz)	$f_{\max(I/O)out}$	Maximum frequency <sup>(2)</sup>	$C_L = 50pF$ , $V_{DD} = 2V \sim 3.6V$		10	MHz
	$t_{f(I/O)out}$	Output fall time	$C_L = 50pF$ , $V_{DD} = 2V \sim 3.6V$		$25^{(3)}$	nS
	$t_{r(I/O)out}$	Output rise time			$25^{(3)}$	
10 (20MHz)	$f_{\max(I/O)out}$	Maximum frequency <sup>(2)</sup>	$C_L = 50pF$ , $V_{DD} = 2V \sim 3.6V$		20	MHz
	$t_{f(I/O)out}$	Output fall time	$C_L = 50pF$ , $V_{DD} = 2V \sim 3.6V$		$125^{(3)}$	nS

OSPEEDRy [1:0] value (1)	Symbol	Parameter	Conditions	Min	Max	Unit
	$t_{r(IO)out}$	Output rise time			125 <sup>(3)</sup>	
11 (50MHz)	$f_{max(IO)out}$	Maximum frequency <sup>(2)</sup>	$C_L = 30pF,$ $V_{DD} = 2.7V \sim 3.6V$		50	MHz
			$C_L = 50pF,$ $V_{DD} = 2.7V \sim 3.6V$		30	
			$C_L = 50pF,$ $V_{DD} = 2V \sim 2.7V$		20	
	$t_{f(IO)out}$	Output fall time	$C_L = 30pF,$ $V_{DD} = 2.7V \sim 3.6V$		5	nS
			$C_L = 50pF,$ $V_{DD} = 2.7V \sim 3.6V$		8	
			$C_L = 50pF,$ $V_{DD} = 2V \sim 2.7V$		12	
	$t_{r(IO)out}$	Output rise time	$C_L = 30pF,$ $V_{DD} = 2.7V \sim 3.6V$		5	nS
			$C_L = 50pF,$ $V_{DD} = 2.7V \sim 3.6V$		8	
			$C_L = 50pF,$ $V_{DD} = 2V \sim 2.7V$		12	
	$t_{EXTIpw}$	Pulse width of external signals detected by the EXTI controller		10		nS

1. The speed of the I/O port can be configured via MODEx[1:0]. See the description of the GPIO Port Configuration Register in this chip reference manual.
2. The maximum frequency is defined in figure 17.

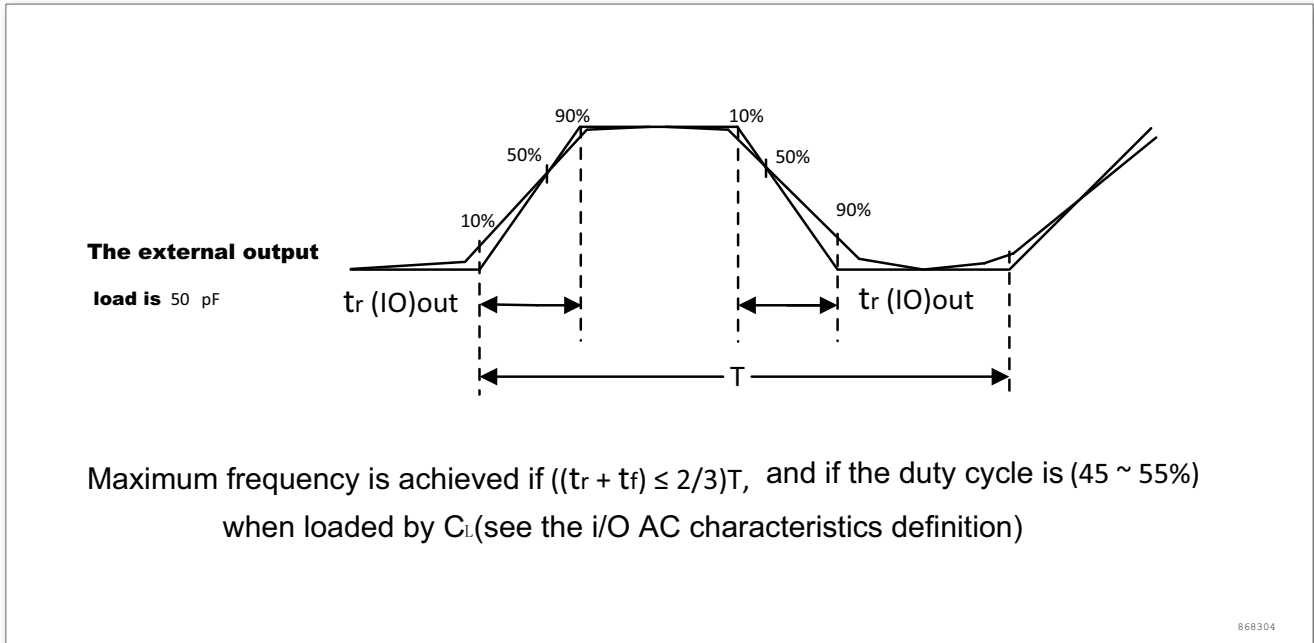

Figure 17. I/O AC characteristics

### 5.3.13 NRST pin characteristics

The NRST pin input driver uses the CMOS technology. It is connected to a permanent pullup resistor,  $R_{PU}$ .

Unless otherwise stated, the parameters listed in the table below are measured using the ambient temperature and  $V_{DD}$  supply voltage in accordance with the condition Table 9.

Table 35. NRST pin characteristics

Symbol	Parameter	Conditions	Min	Typ	Max	Unit
$V_{IL(NRST)}^{(1)}$	NRST input low level voltage		-0.5		0.8	V
$V_{IH(NRST)}^{(1)}$	NRST input high level voltage		2		$V_{DD}$	
$V_{hys(NRST)}$	NRST Schmitt trigger voltage hysteresis			$0.2V_{DD}$		V
$R_{PU}$	Weak pull-up equivalent resistor <sup>(2)</sup>	$V_{IN} = V_{SS}$		15		kΩ
$V_{F(NRST)}^{(1)}$	NRST input filtered pulse				100	ns
$V_{NF(NRST)}^{(1)}$	NRST input not filtered pulse		300			

1. Data based on design simulation only. Not tested in production.
2. The pull-up is designed with a true resistance in series with a switchable PMOS. This PMOS contribution to the series resistance is minimal (10% order).

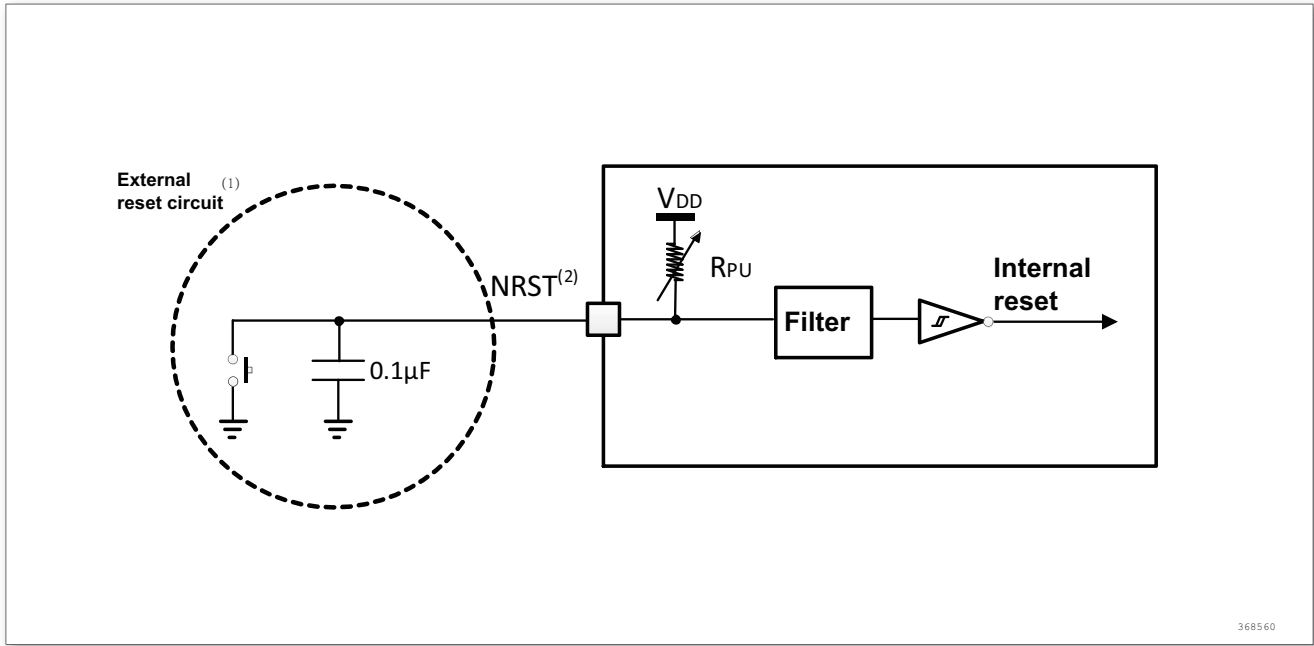

Figure 18. Recommended NRST pin protection

1. The reset network is to prevent parasitic reset
2. The user must ensure that the potential of the NRST pin is below the maximum  $V_{IL(NRST)}$  listed in Table 35, otherwise the MCU cannot be reset.

### 5.3.14 Timer characteristics

The parameters given in the following tables are guaranteed by design.

For details on the characteristics of the I/O multiplexing function pins (output compare, input capture, external clock, PWM output) , see subsubsec 5.3.12.

Table 36. TIMx<sup>(1)</sup> characteristics

Symbol	Parameter	Conditions	Min	Max	Unit
$t_{res(TIM)}$	Timer resolution time		1		$t_{TIMxCLK}$
		$f_{TIMxCLK} = 96MHz$	10.4		nS
$f_{EXT}$	Timer external clock frequency on CH1 to CH4		0	$f_{TIMxCLK}/2$	MHz
		$f_{TIMxCLK} = 96MHz$	0	48	
$ReS_{TIM}$	Timer resolution			16	Bit
$t_{COUNTER}$	16-bit timer maximum period		1	65536	$t_{TIMxCLK}$
		$f_{TIMxCLK} = 96MHz$	0.0104	682	$\mu S$
$t_{MAX\_COUNT}$	The maximum possible count			$65536 \times 65536$	$t_{TIMxCLK}$
		$f_{TIMxCLK} = 96MHz$		44.7	S

1. TIMx is a generic name, representing TIM4.

### 5.3.15 Communication interfaces

#### I2C interface characteristics

Unless otherwise specified, the parameters given in Table 37 are derived from tests performed under the ambient temperature,  $f_{PCLK1}$  frequency and supply voltage conditions summarized in Table 12: General operating conditions.

The I2C interface conforms to the standard I2C communication protocol, but has the following limitations: SDA and SCL are not true pins. When configured as open-drain output, the PMOS transistor between the pin and  $V_{DD}$  Was closed but still exists.

The I2C I/Os characteristics are listed in Table 37, the alternate function characteristics of I/Os (SDA and SCL) refer to subsubsec 5.3.12.

Table 37. I2C characteristics

Symbol	Parameter	Standard I2C <sup>(1)</sup>		Fast I2C <sup>(1)(2)</sup>		Unit
		Min	Max	Min	Max	
$t_{w(SCL)}$	SCL clock fall time	4.7		1.3		$\mu$ s
$t_{w(SCLH)}$	SCL clock rise time	4.0		0.6		$\mu$ s
$t_{su(SDA)}$	SDA setup time	250		100		ns
$t_{h(SDA)}$	SDA data hold time	0 <sup>(3)</sup>		0 <sup>(4)</sup>	900 <sup>(3)</sup>	
$t_{r(SDA)}$ $t_{r(SDL)}$	SDA and SCL rise time		1000	$2.0+0.1C_b$	300	
$t_{f(SDA)}$ $t_{f(SDL)}$	SDA and SCL fall time		300		300	
$t_{h(STA)}$	Start condition hold time	4.0		0.6		
$t_{su(STA)}$	Start condition setup time	4.7		0.6		$\mu$ s
$t_{su(STO)}$	Stop condition setup time	4.0		0.6		
$t_{w(STO:STA)}$	Time from Stop condition to Start condition	4.7		1.3		
$C_b$	Capacitive load of each bus		400		400	pF

1. Guaranteed by design, not tested in production.
2.  $f_{PCLK1}$  must be at least 3MHz to achieve standard mode I2C frequencies. It must be at least 12MHz to achieve fast mode I2C frequencies.
3. The maximum Data hold time has only to be met if the interface does not stretch the low period of SCL signal.
4. In order to span the undefined area of the falling edge of SCL, it must ensure that the SDA signal has a hold time of at least 300nS.

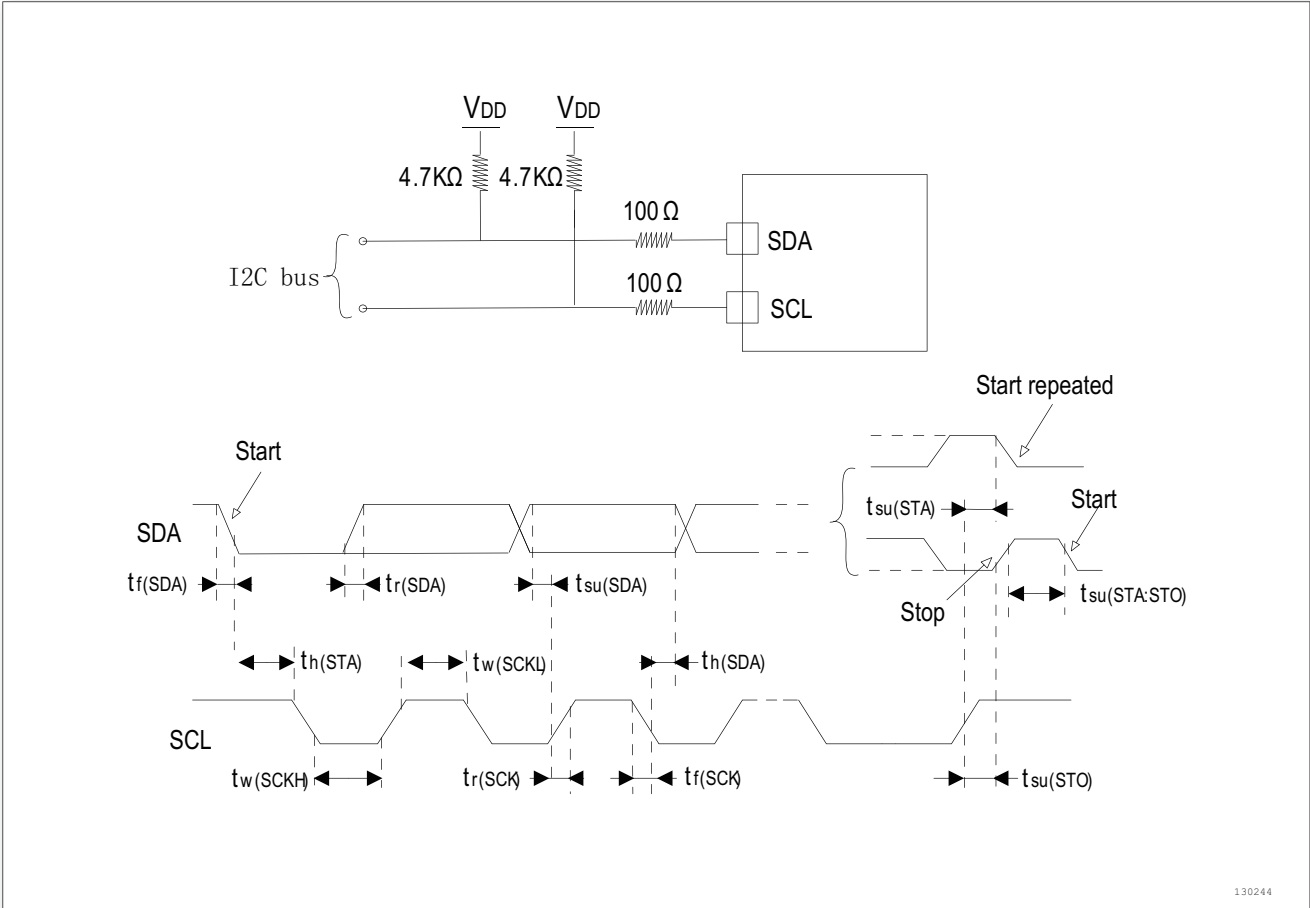

Figure 19. I2C bus AC waveform and measurement circuit<sup>(1)</sup>

1. Measurement point is set to the CMOS level: 0.3V<sub>DD</sub> and 0.7V<sub>DD</sub>.

**SPI characteristics**

Unless otherwise specified, the parameters given in Table 38 are derived from tests performed under the ambient temperature, f<sub>PCLKx</sub> frequency and V<sub>DD</sub> supply voltage conditions summarized in Table 12.

Refer to subsubsec 5.3.12 for more details on the input/output alternate function characteristics (NSS, SCK, MOSI, MISO).

Table 38. SPI characteristics<sup>(1)</sup>

Symbol	Parameter	Conditions	Min	Max	Unit
f <sub>SCK</sub> 1/t <sub>c(SCK)</sub>	SPI clock frequency	Master mode	0	36	MHz
		Slave mode	0	18	
t <sub>r(SCK)</sub> t <sub>f(SCK)</sub>	SPI clock rise and fall time	Load capacitance: C = 30pF		8	ns
t <sub>su(NSS)</sub> <sup>(2)</sup>	NSS setup time	Slave mode	4t <sub>PCLK</sub>		
t <sub>h(NSS)</sub> <sup>(2)</sup>	NSS hold time	Slave mode	73		
t <sub>w(SCKH)</sub> <sup>(2)</sup> t <sub>w(SCKL)</sub> <sup>(2)</sup>	SCK high and low time	Master mode, f <sub>PCLK</sub> = 36MHz, prescale coefficient = 4	50	60	

Symbol	Parameter	Conditions	Min	Max	Unit
$t_{su(MI)}^{(2)}$	Data input setup time, Master mode	SPI1	1		
$t_{su(SI)}^{(2)}$	Data input setup time, Slave mode		1		

Symbol	Parameter	Conditions	Min	Max	Unit
$t_{h(MI)}^{(2)}$	Data input hold time, Master mode	SPI1	1		ns
$t_{h(SI)}^{(2)}$	Data input hold time, Slave mode		3		
$t_{a(SO)}^{(2)(3)}$	Data output access time	Slave mode, $f_{PCLK} = 36\text{MHz}$ , prescale coefficient = 4	0	55	
		Slave mode, $f_{PCLK} = 24\text{MHz}$		$4t_{PCLK}$	
$t_{dis(SO)}^{(2)(4)}$	Data output disable time	Slave mode	10		
$t_{v(SO)}^{(2)(1)}$	Data output valid time	Slave mode (after enable edge)		25	
$t_{v(MO)}^{(2)(1)}$	Data output valid time	Master mode (after enable edge)		3	
$t_{h(SO)}^{(2)}$	Data output hold time	Slave mode (after enable edge)	25		
$t_{h(MO)}^{(2)}$		Master mode (after enable edge)	4		

1. Remapping SPI1 characteristics needs to be further determined.
2. Data based on characterization results. Not tested in production.
3. Min time is for the minimum time to drive the output and the max time is for the maximum time to validate the data.
4. Min time is for the minimum time to invalidate the output and the max time is for the maximum time to put the data in Hi-Z.



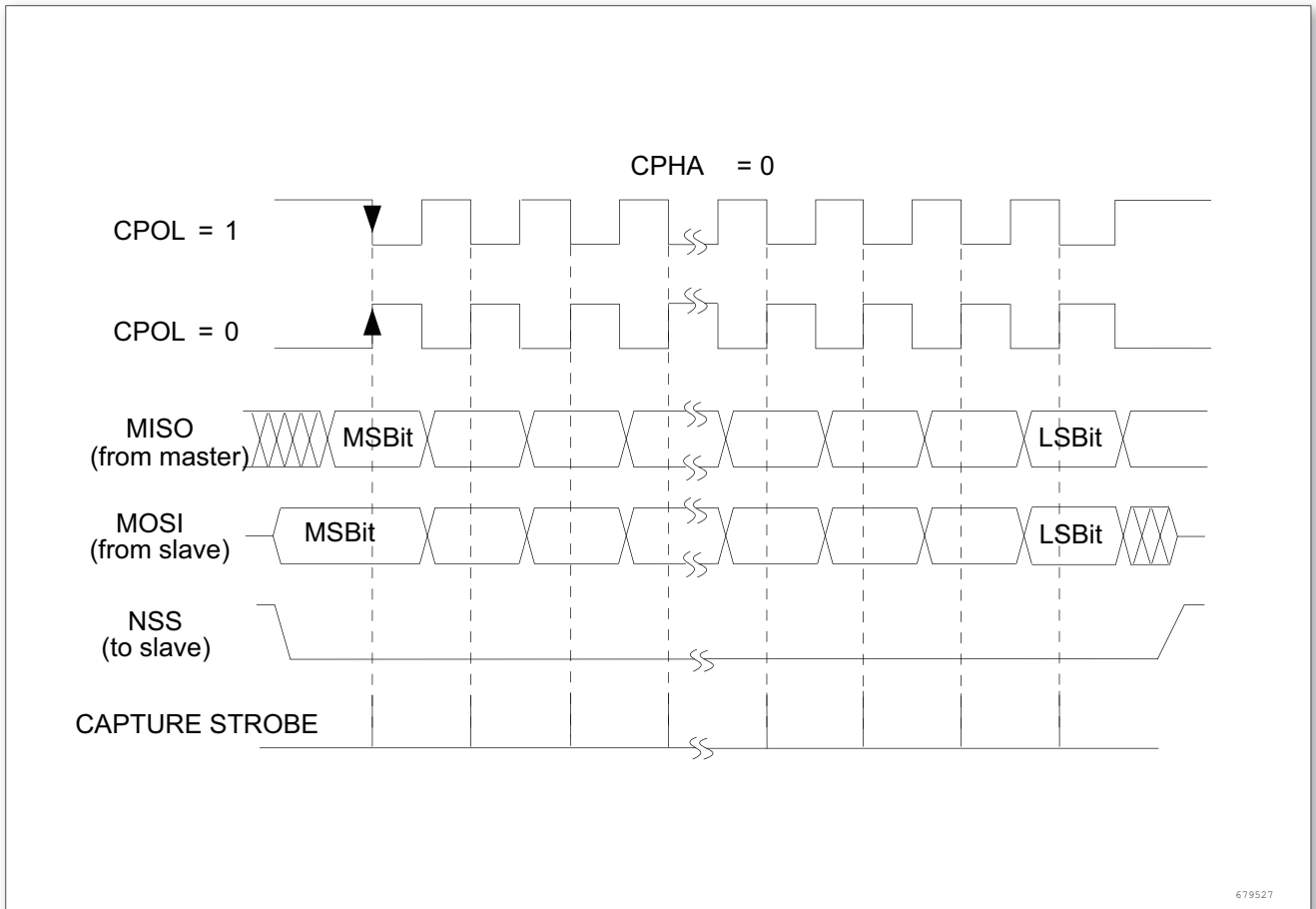

Figure 20. SPI timing diagram-slave mode and CPHA = 0

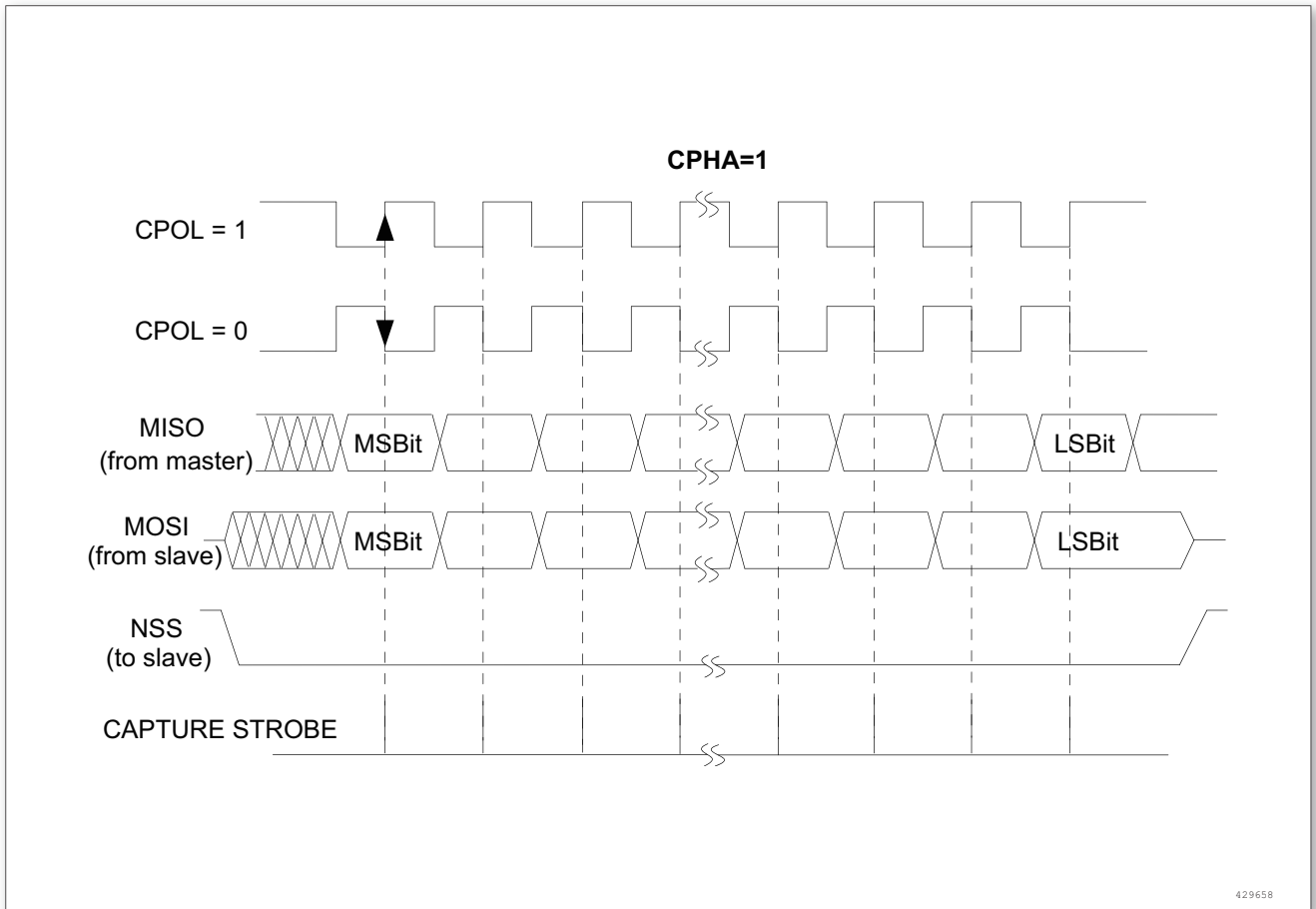

Figure 21. SPI timing diagram-slave mode and CPHA = 1<sup>(1)</sup>

1. Measurement points are done at CMOS levels: 0.3V<sub>DD</sub> and 0.7V<sub>DD</sub>.

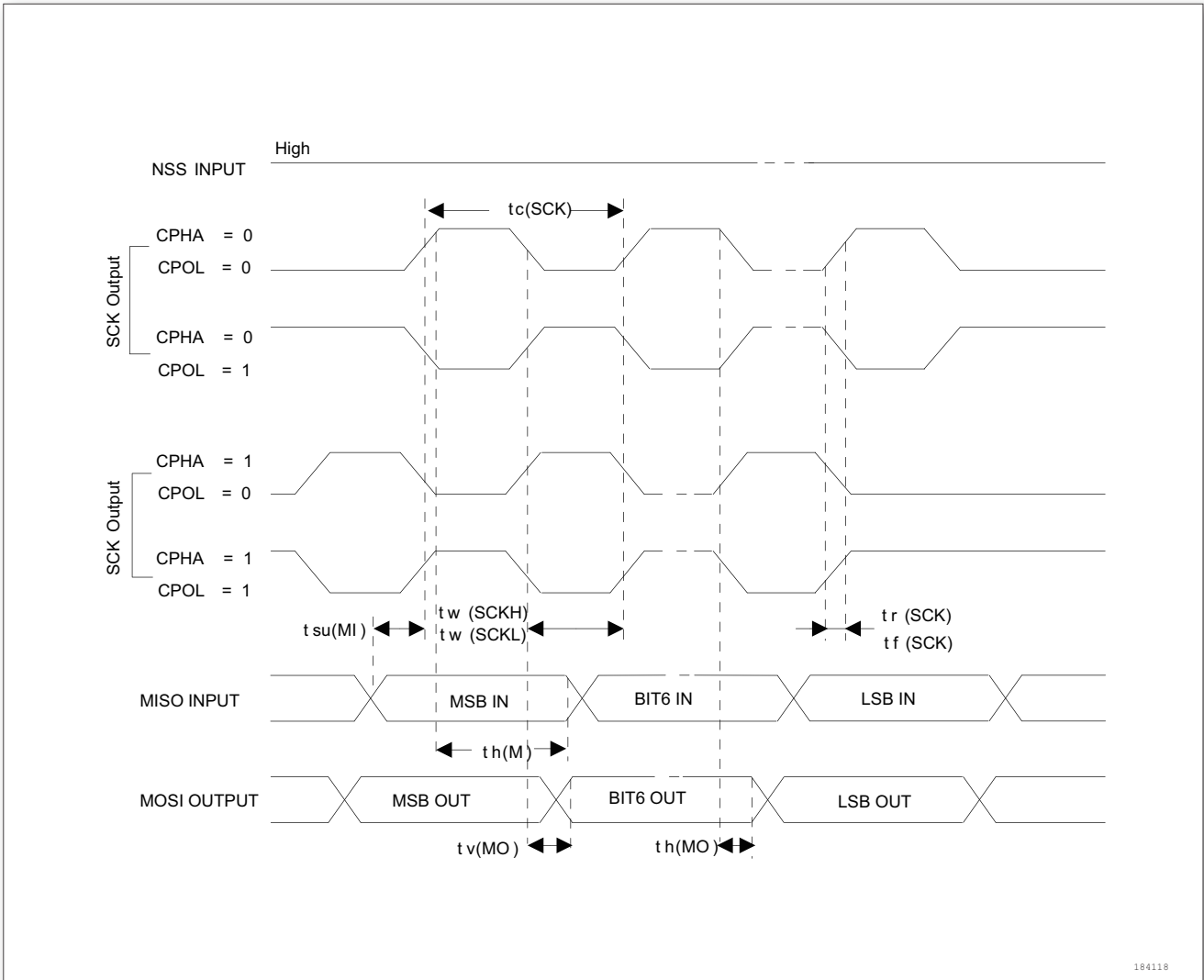

Figure 22. SPI timing diagram-master mode<sup>(1)</sup>

1. Measurement points are done at CMOS levels:  $0.3V_{DD}$  and  $0.7V_{DD}$ .

### 5.3.16 12-bit ADC characteristics

Unless otherwise specified, The parameters in the table below are measured using the ambient temperature,  $f_{PCLK2}$  frequency and  $V_{DDA}$  supply voltage in accordance with the conditions of Table 12.

*Note: It is recommended to perform a calibration after each power-up*

Table 39. ADC characteristics

Symbol	Parameter	Conditions	Min	Type	Max	Unit
$V_{DDA}$	Supply voltage		2.5	5	5.5	V
$V_{REF+}$	Positive reference voltage			$V_{DDA}$		V

Symbol	Parameter	Conditions	Min	Type	Max	Unit
$f_{ADC}^{(1)(3)}$	ADC clock frequency				15	MHz
$f_S^{(1)(3)}$	Sampling rate				1	MHz
$f_{TRIG}^{(1)}$	External trigger frequency	$f_{ADC} = 15\text{MHz}$			833	KHz
					18	$1/f_{ADC}$
$V_{AIN}^{(2)}$	Conversion voltage range		0 ( $V_{SSA}$ or $V_{REF-}$ connected to ground)		$V_{REF+}$	V
$R_{AIN}^{(1)}$	External sample and hold capacitor		See Formulas 1 and Table 40			$k\Omega$
$R_{ADC}^{(1)}$	Sampling switch resistance				0.75	$k\Omega$
$C_{ADC}^{(1)}$	Internal sample and hold capacitor			10		pF
$t_S^{(1)}$	Sampling time	$f_{ADC} = 15\text{MHz}$	0.1		16	$\mu\text{s}$
			1.5		239.5	$1/f_{ADC}$
$t_{STAB}^{(1)}$	Stabilization time			1		$\mu\text{s}$
$t_{conv}^{(1)}$	Total conversion time (including Sampling time)	$f_{ADC} = 15\text{MHz}$	1		17.44	$\mu\text{s}$
			15 ~ 253 (sampling $t_{S+}$ ) stepwise approximation 13.5			$1/f_{ADC}$

1. Guaranteed by design. Not tested in production.
2. In this series of products,  $V_{REF+}$  is internally connected to  $DDA$ ,  $V_{REF-}$  is internally connected to  $SSA$ .
3.  $f_{ADC}$  Maximum support 15MHz,  $f_S$  Maximum support 1MHz ( $f_{CLK2} = 60\text{MHz}$ , ADC Prescaler = 4,  $f_{ADC} = 15\text{MHz}$ ,  $T_S = 1.5$ )

#### Formula 1: Maximum $R_{AIN}$ Formula

$$R_{AIN} < \frac{T_S}{f_{ADC} \times C_{ADC} \times (N + 3) \times \ln(2)} - R_{ADC}$$

The above formula (Equation 1) is used to determine the maximum external impedance so that the error can be less than 1/4 LSB. Where  $N = 12$  (representing 12-bit resolution) .  $\ln(2) = 0.69314718$ .

Table 40. Maximum  $R_{AIN}$  at  $f_{ADC} = 15\text{MHz}^{(1)}$

$T_S$ (cycles)	$t_S$ ( $\mu\text{s}$ )	$R_{AIN}$ max ( $k\Omega$ )
1.5	0.1	0.2
7.5	0.5	4.1
13.5	0.9	7.9
28.5	1.9	17.5
41.5	2.8	25.9

T <sub>S</sub> (cycles)	t <sub>S</sub> (μs)	R <sub>AIN</sub> max (kΩ)
55.5	3.7	34.8
71.5	4.8	NA
239.5	16.0	NA

1. Guaranteed by design. Not tested in production.

Table 41. ADC Accuracy - Limit Test Conditions<sup>(1)(2)</sup>

Symbol	Parameter	Test Conditions	Type	Max	Unit
ET	Comprehensive error	f <sub>PCLK2</sub> = 60MHz, f <sub>ADC</sub> = 15MHz, R <sub>AIN</sub> < 10KΩ, V <sub>DDA</sub> = 5V, T <sub>A</sub> = 25°C	8	10	LSB
EO	Offset error		3	3	
EG	Gain error		1	1	
ED	Differential linearity error		6.5	7	
EL	Integral linearity error		8	8	

1. ADC Accuracy vs. Negative Injection Current: Injecting negative current on any of the standard (non-robust) analog input pins should be avoided as this significantly reduces the accuracy of the conversion being performed on another analog input. It is recommended to add a Schottky diode (pin to ground) to standard analog pins which may potentially inject negative current.

Any positive injection current within the limits specified for I<sub>INJ(PIN)</sub> and ΣI<sub>INJ(PIN)</sub> in subsubsec 5.3.13 does not affect the ADC accuracy.

2. Guaranteed based on test during characterization. Not tested in production.

ET = Total unadjusted error: The maximum deviation between the actual and ideal transmission curves.

EO = Offset error: The deviation between the first actual conversion and the first ideal conversion.

EG = Gain error: The deviation between the last ideal transition and the last actual transition.

ED = Differential linearity error: The maximum deviation between the actual step and the ideal value.

EL = Integral linearity error: The maximum deviation between any actual conversion and the associated line of the endpoint.

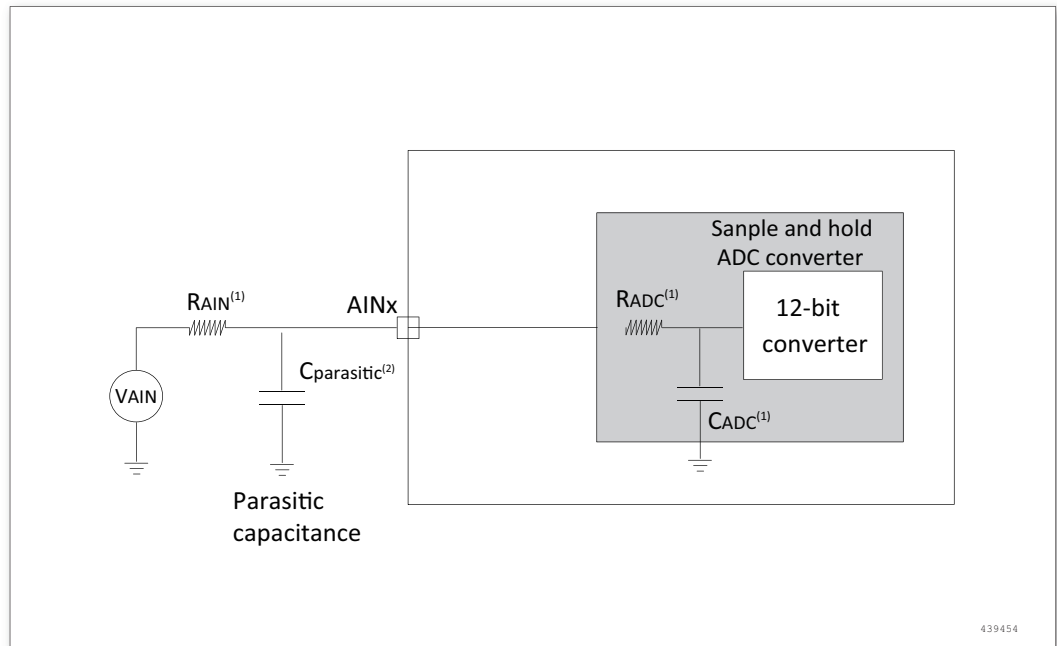

Figure 23. Typical connection diagram using the ADC

1. See Table 41 for the values of  $R_{AIN}$ ,  $R_{ADC}$  and  $C_{ADC}$ .
2.  $C_{parasitic}$  represents the capacitance of the PCB (dependent on soldering and PCB layout quality) plus the pad capacitance (roughly 7pF) . A high  $C_{parasitic}$  value will downgrade conversion accuracy. To remedy this,  $f_{ADC}$  should be reduced.

### PCB design recommendations

The power supply must be connected as shown below. The 10nF capacitor in the figure must be a ceramic capacitor (good quality) , and they should be as close as possible to the MCU chip.

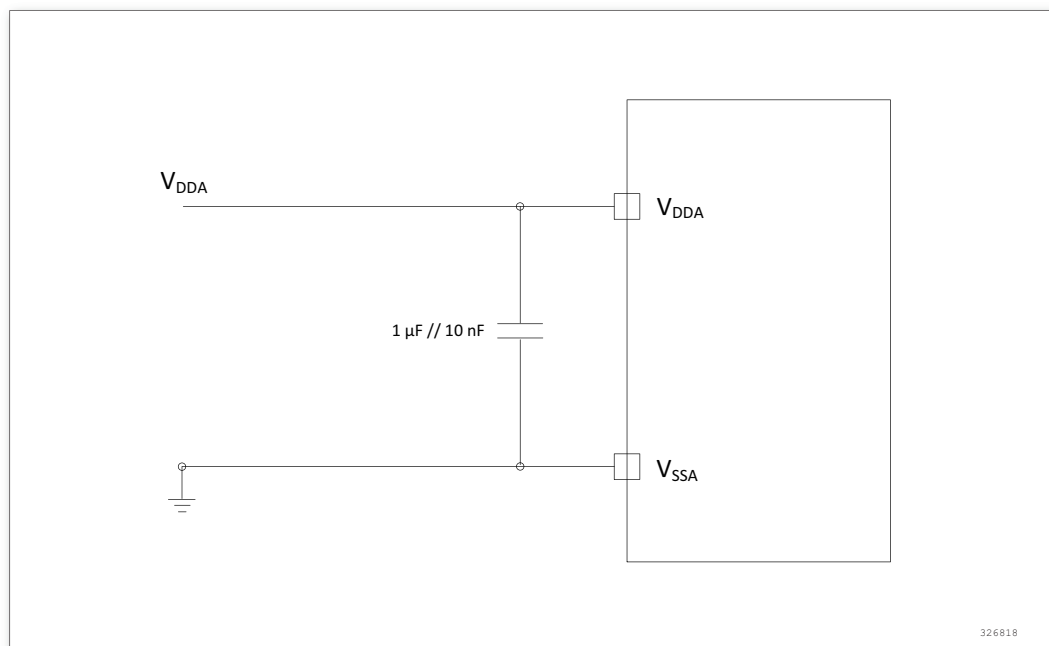

Figure 24. Power supply and reference power supply decoupling circuit

### 5.3.17 Temperature sensor characteristics

Table 42. Temperature sensor characteristics<sup>(3)</sup> <sup>(4)</sup>

Symbol	Parameter	Min	Type	Max	Unit
$T_L^{(1)}$	$V_{SENSE}$ linearity with respect to temperature		$\pm 5$		$^{\circ}C$
Avg_Slope <sup>(1)</sup>	Average slope	4.571	4.801	5.984	mV/ $^{\circ}C$
$V_{25}^{(1)}$	Voltage at 25 $^{\circ}C$	1.433	1.451	1.467	V
$t_{start}^{(2)}$	Setup time			10	$\mu s$
$T_{S\_temp}^{(2)}$	ADC sampling time when reading temperature	10			$\mu s$

1. Guaranteed based on test during characterization. Not tested in production.
2. Guaranteed by design. Not tested in production.
3. The shortest Sampling time can be determined by the application through multiple iterations.
4.  $V_{DD} = 3.3V$ .

# 6

## Package information

Package information

### 6.1 LQFP48 Package information

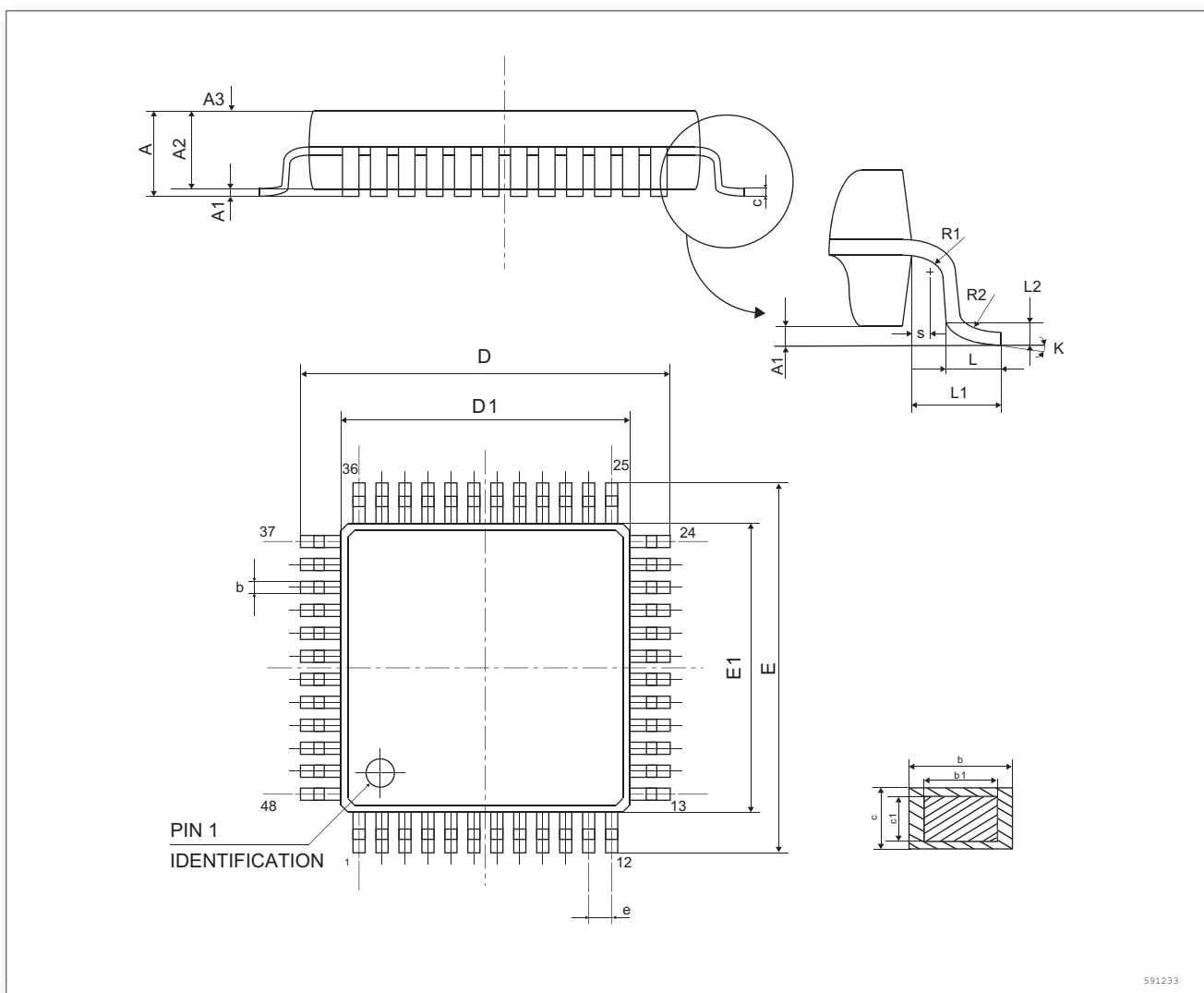

Figure 25. LQFP48 - 48-pin low-profile quad flat package outline

- 1. Drawing is not to scale.
- 2. Dimensions are expressed in millimeters.



Table 43. LQFP48 mechanical data

Symbol	Millimeters		
	Min	Typ	Max
A			1.60
A1	0.05		0.15
A2	1.35	1.40	1.45
A3	0.59	0.64	0.69
b	0.18		0.27
b1	0.17	0.20	0.23
c	0.13		0.18
c1	0.12	0.127	0.134
D	8.80	9.00	9.20
D1	6.90	7.00	7.10
E	8.80	9.00	9.20
E1	6.90	7.00	7.10
e		0.50	
L	0.45	0.60	0.75
L1	1.00REF		
L2	0.25BSC		
R1	0.08		
R2	0.08		0.20
S	0.20		
N	Number of pins = 48		

## 6.2 LQFP32 Package information

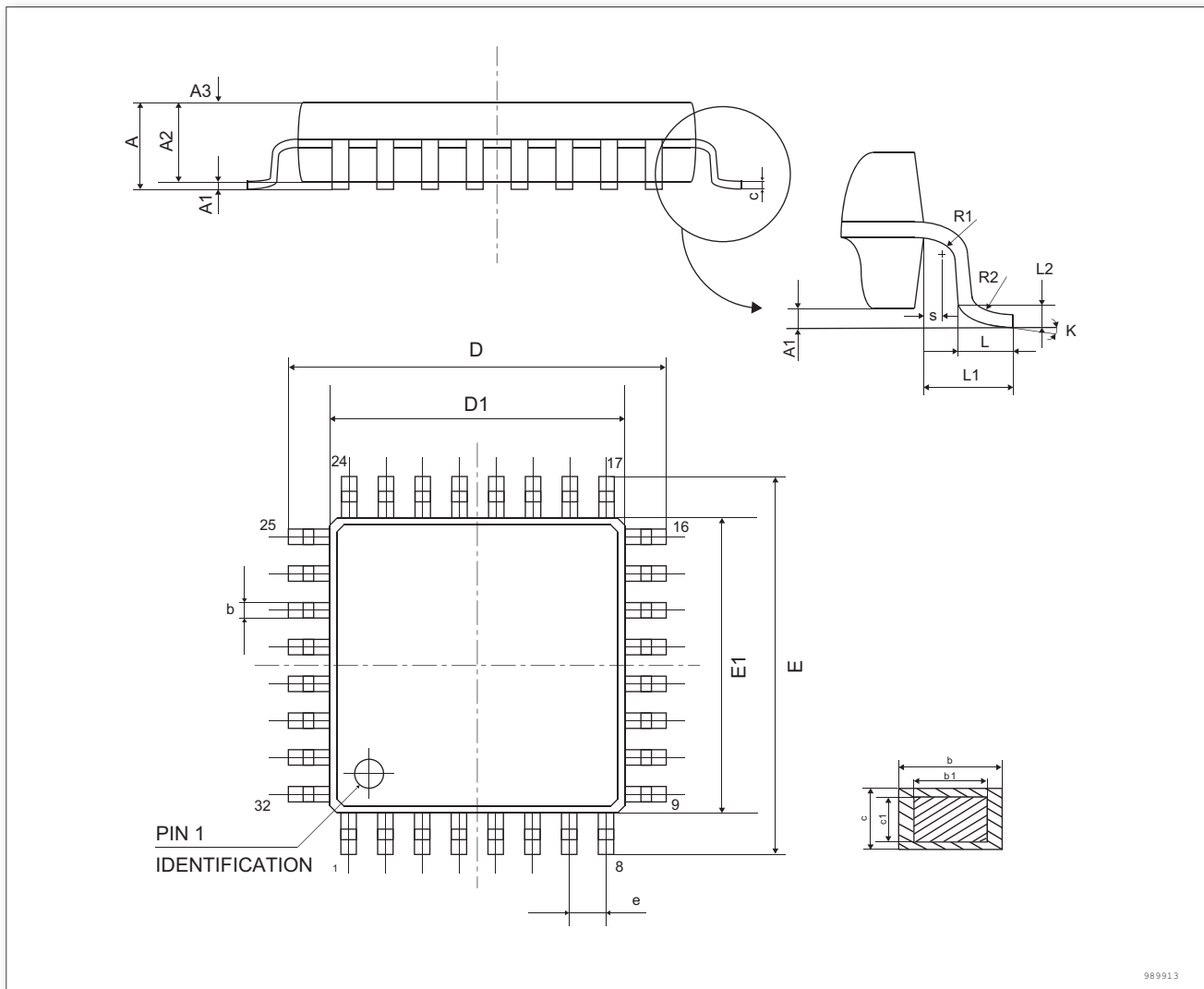

Figure 26. LQFP32 - 32-pin low-profile quad flat package outline

1. Drawing is not to scale.
2. Dimensions are expressed in millimeters.

Table 44. LQFP32 mechanical data

Symbol	Millimeters		
	Min	Typ	Max
A			1.60
A1	0.05		0.15
A2	1.35	1.40	1.45
A3	0.59	0.64	0.69
b	0.32		0.43
b1	0.31	0.35	0.39
c	0.13		0.18
c1	0.12	0.127	0.134

Symbol	Millimeters		
	Min	Typ	Max
D	8.80	9.00	9.20
D1	6.90	7.00	7.10
E	8.80	9.00	9.20
E1	6.90	7.00	7.10
e		0.80	
L	0.45	0.60	0.75
L1	1.00REF		
L2	0.25BSC		
R1	0.08		
R2	0.08		0.20
S	0.20		
N	Number of pins = 32		

### 6.3 QFN32 Package information

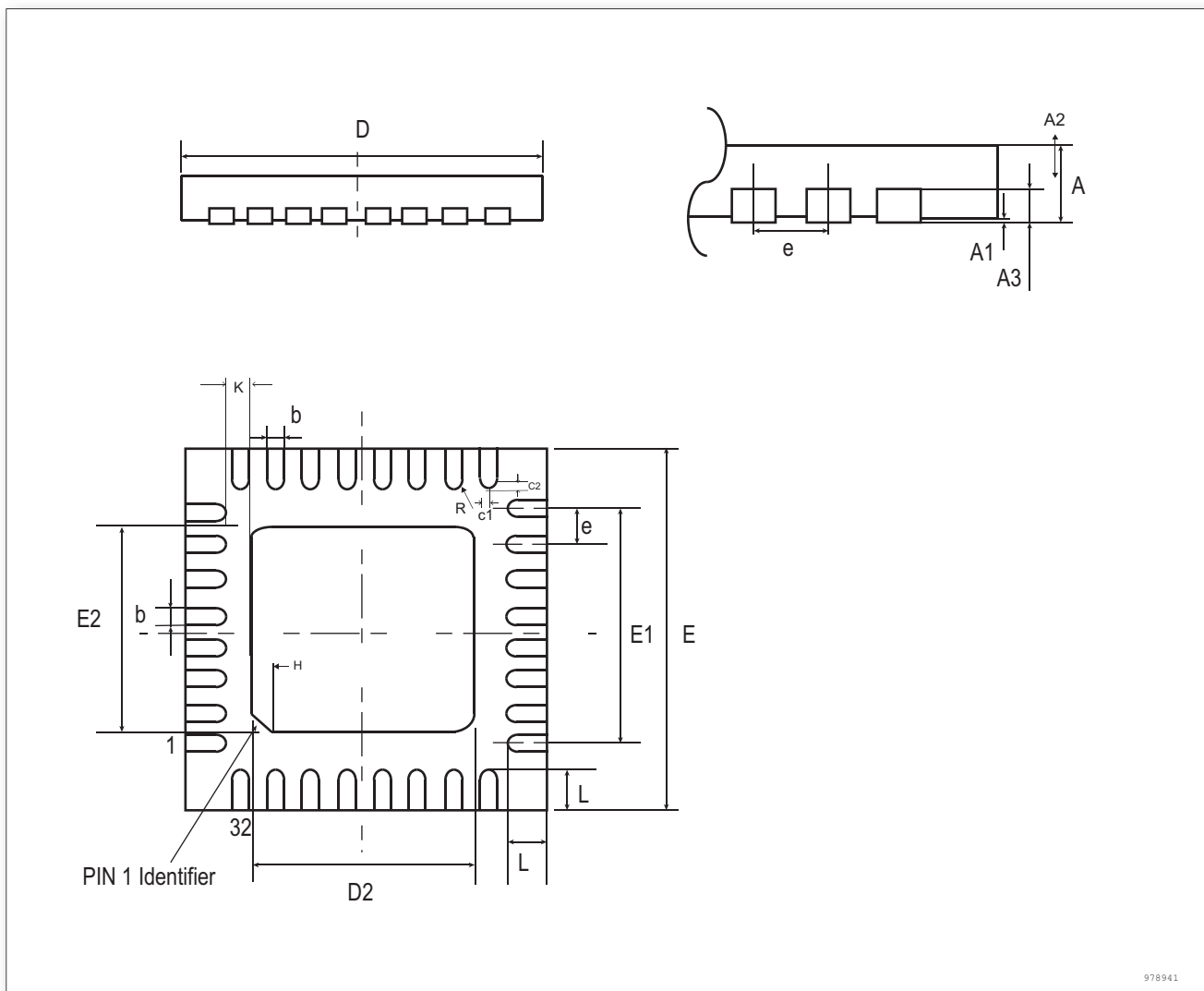

Figure 27. QFN32 - 32-pin quad flat no-leads package outline

1. Drawing is not to scale.
2. Dimensions are expressed in millimeters.

Table 45. QFN32 mechanical data

Symbol	Millimeters		
	Min	Typ	Max
A	0.7	0.75	0.80
A1	0.00	0.02	0.05
A2	0.50	0.55	0.60
A3	0.20REF		
b	0.20	0.25	0.30
D	4.90	5.00	5.10
E	4.90	5.00	5.10
D2	3.40	3.50	3.60

Symbol	Millimeters		
	Min	Typ	Max
E2	3.40	3.50	3.60
e		0.5	
H	0.30REF		
K	0.35REF		
L	0.35	0.40	0.45
R	0.09		
c1		0.08	
c2		0.08	
N	Number of pins = 32		

### 6.4 QFN20 Package information

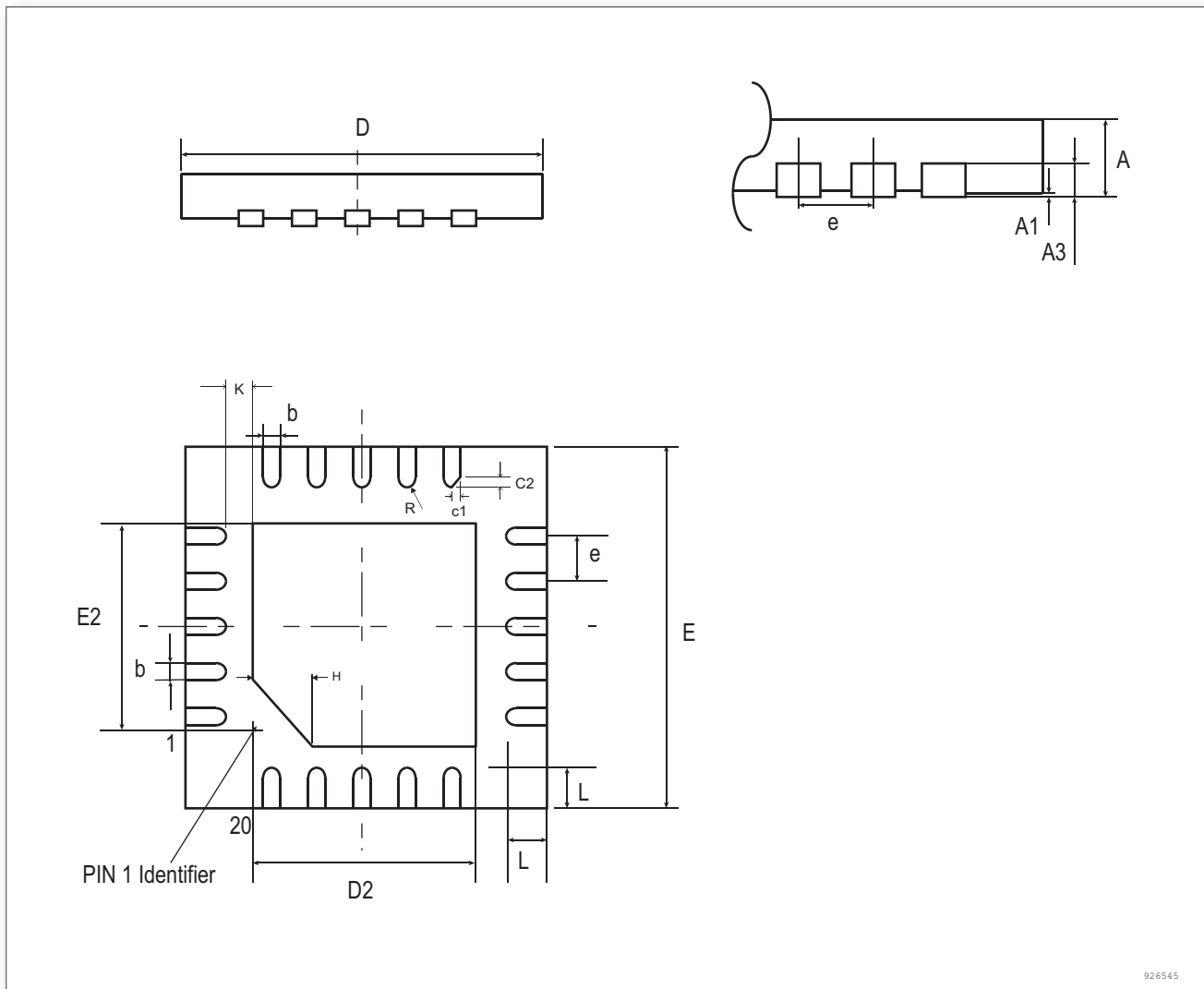

Figure 28. QFN20 - 20-pin quad flat no-leads package outline

1. Drawing is not to scale.
2. Dimensions are expressed in millimeters.

Table 46. QFN20 mechanical data

Symbol	Millimeters		
	Min	Typ	Max
A	0.50	0.55	0.60
A1	0.00	0.02	0.05
A3	0.152REF		
b	0.15	0.20	0.25
D	2.90	3.00	3.10
E	2.90	3.00	3.10
D2	1.40	1.50	1.60
E2	1.40	1.50	1.60

Symbol	Millimeters		
	Min	Typ	Max
e		0.40	
H	0.35REF		
K	0.40REF		
L	0.25	0.35	0.45
R	0.075		
N	Number of pins = 20		

### 6.5 TSSOP20 Package information

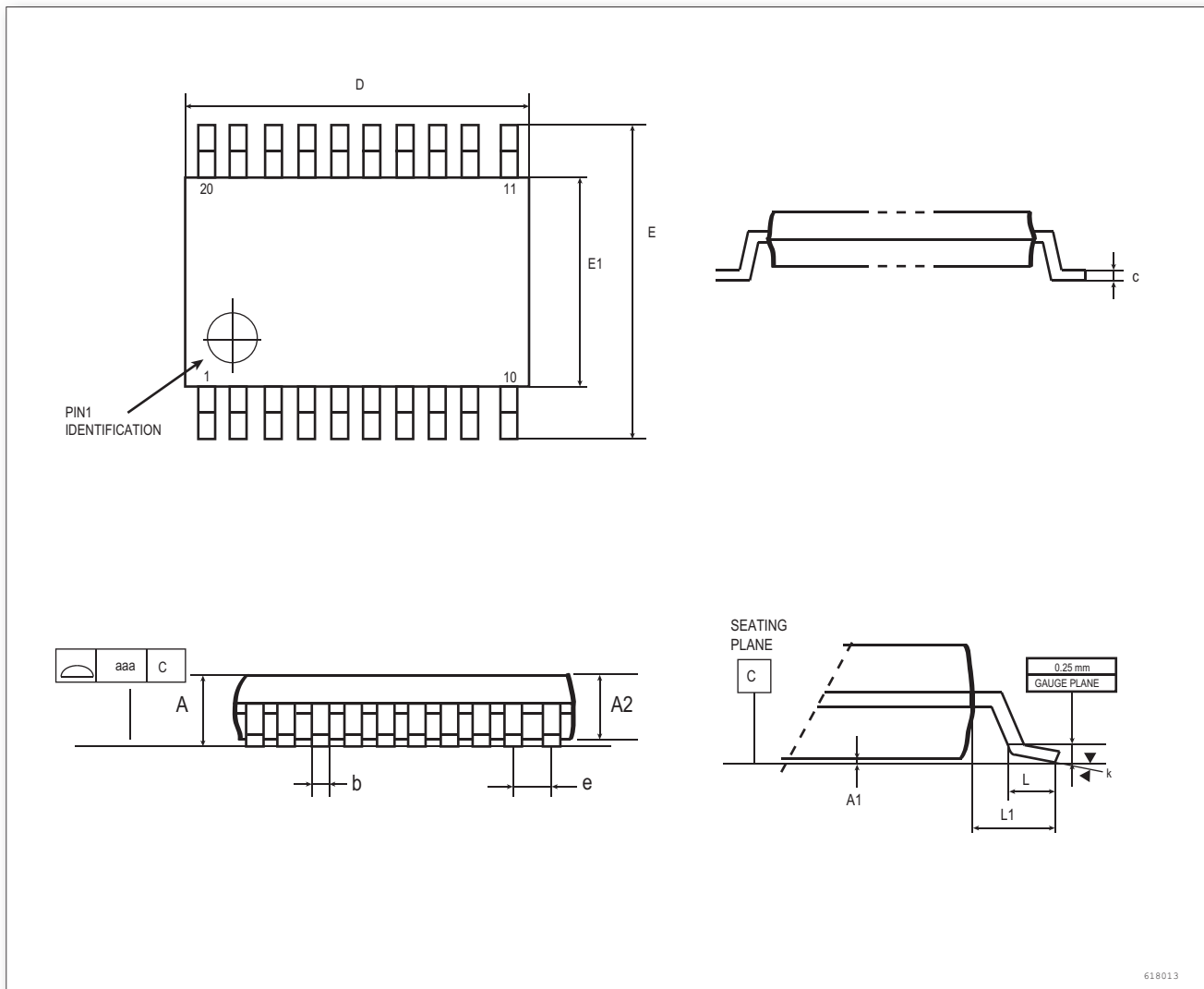

Figure 29. TSSOP20 - 20-lead thin shrink small outline package outline

1. Drawing is not to scale.
2. Dimensions are expressed in millimeters.

Table 47. TSSOP20 mechanical data

Symbol	Millimeters		
	Min	Typ	Max
A			1.20
A1	0.05		0.15
A2	0.8	1.00	1.05
b	0.19		0.30
c	0.09		0.20
D	6.40	6.50	6.60
E	6.25	6.40	6.55
E1	4.30	4.40	4.50



Symbol	Millimeters		
	Min	Typ	Max
e	0.65		
L	0.45	0.60	1
L1	0.45		0.75
N	Number of pins = 20		

# 7

## Ordering information

Ordering information

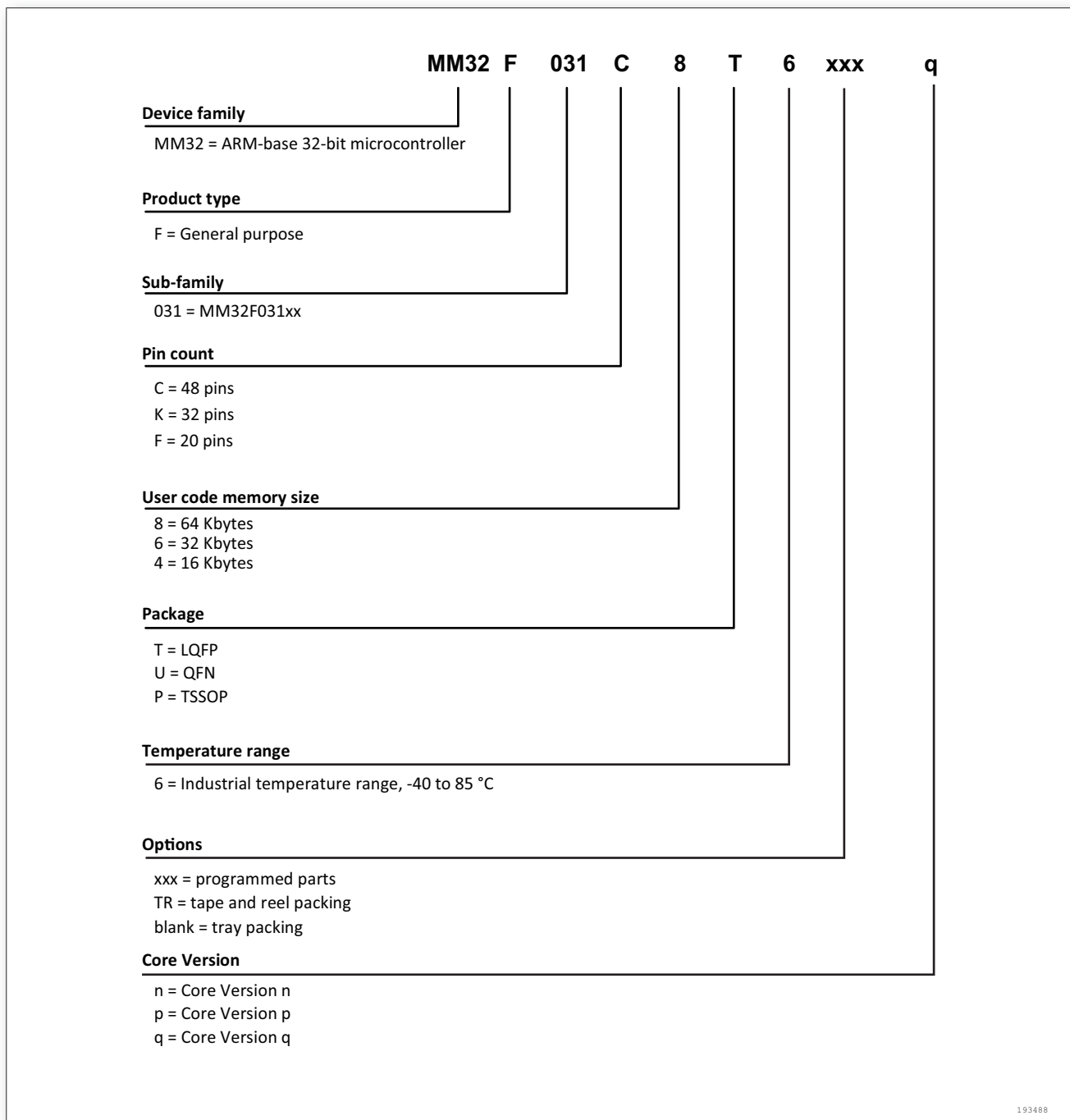

Figure 30. Ordering information scheme