

DESIGNED FOR USE WITH	.141 SR
CABLE ENTRY DIAMETER MINIMUM	
HOUSING	.161
SLEEVE	.146
CONTACT	.039

REVISIONS			
REV	DESCRIPTION	DATE	APPROVED
01 <sub>0</sub>	RELEASED	9/20/96	<i>[Signature]</i>

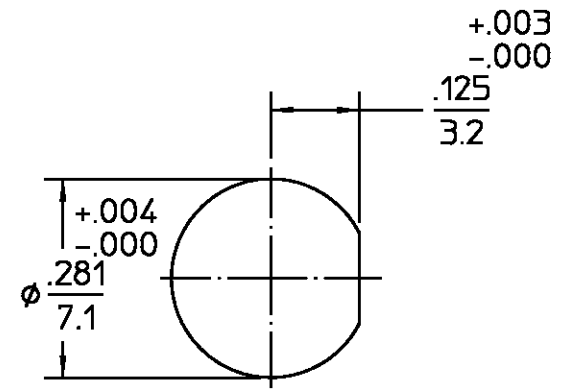

RECOMMENDED MOUNTING HOLE

ELECTRICAL	MECHANICAL	ENVIRONMENTAL
Nominal Impedance (Ohms) <u>50</u>	Interface Dimensions MIL-STD-348A, Fig. <u>310-2</u>	Temperature Rating <u>-65 TO 165°C</u>
Frequency Range (GHz) DC to <u>18</u>	Recommended Mating Torque <u>7-10 IN-LBS</u>	Vibration MIL-STD-202, Method 204, Condition D
Volt Rating (VRMS MAX) @ Sea Level <u>500</u>	Mating Characteristics: Insertion (MAX Lbs) <u>2</u>	Shock MIL-STD-202, Method 213, Condition I
VSWR <u>1.05 + 0.0F(GHz)</u>	Withdrawal (MIN Oz) <u>1</u>	Thermal Shock MIL-STD-202, Method 107, Condition B, Except High Temp 115°C
Insertion Loss (dB MAX) <u>.03</u> $\sqrt{\text{GHz}}$	Force to Engage and Disengage (In-Lbs MAX) <u>2</u>	Moisture Resistance MIL-STD-202, Method 106
RF Leakage (dB MIN) <u>-90</u>	Center Contact Captivation Axial (Lbs) <u>6</u>	Corrosion - MIL-STD-202, Method 101, Condition B, 5% salt spray
Corona, 70,000 Ft (VRMS MIN) <u>375</u>	Radial (In-Oz) <u>N/A</u>	
Dielectric Withstanding Voltage (VRMS MIN) @ Sea Level <u>1,500</u>	Cable Retention Axial Force (Lbs) <u>60</u>	
Contact Resistance (Milliohms MAX) Center Contact <u>3.0</u>	Torque (In-Oz) <u>55</u>	
Outer Contact <u>2.0</u>	Weight (Grams) <u>TBD</u>	
Cable to Housing <u>0.5</u>		
RF High Potential @ Sea Level (VRMS MIN @ 5 MHz) <u>1,000</u>		
LR.(Megohms MIN) <u>5,000</u>		

COMPONENT	MATERIAL	FINISH
HOUSING MOUNTING NUT LOCKWASHER CLAMP NUT	STAINLESS STEEL PER ASTM-A484 AND ASTM-A582, TYPE 303	PASSIVATE PER QQ-P-35
DIELECTRIC	TFE FLUOROCARBON PER ASTM-D-1457	N/A
CENTER CONTACT	BERYLLIUM COPPER PER ASTM-B-196 OR ASTM-B-197, ALLOY C17300, CONDITION H	GOLD PLATE PER MIL-G-45204
SLEEVE	BRASS PER ASTM-B-16, HALF HARD	GOLD PLATE PER MIL-G-45204
O-RING	SILICONE RUBBER PER ZZ-R-765	N/A

UNLESS OTHERWISE SPECIFIED DIMENSIONS ARE IN INCHES

FRAC. ± 1/64	DEC. ± .005	ANGLES ± 1°
--------------	-------------	-------------

DRAWN BY K. LE DATE 8-22-96

CHECKED BY \_\_\_\_\_

APPD BY [Signature] DATE 9/20/96

USE ASSY PROCEDURE

NO. AP. 408-04842 (20-560)

TITLE "OSM" BULKHEAD FEEDTHRU CABLE JACK-SOLDER CLAMP ATTACHMENT

SIZE <u>B</u>	CODE IDENT NO. <u>26805</u>	TITLE NO. <u>2004-8004-92</u>	REV <u>01<sub>0</sub></u>
---------------	-----------------------------	-------------------------------	---------------------------

SCALE 4:1 SHEET 1 OF 1