

DESIGNED FOR USE WITH RG-142/U	
CABLE ENTRY DIAMETER MINIMUM	
HOUSING	.121
DIELECTRIC	.052
CONTACT	.041

REVISIONS			
REV	DESCRIPTION	DATE	APPROVED
01 ₀	RELEASED	11/5/96	<i>RAC</i>

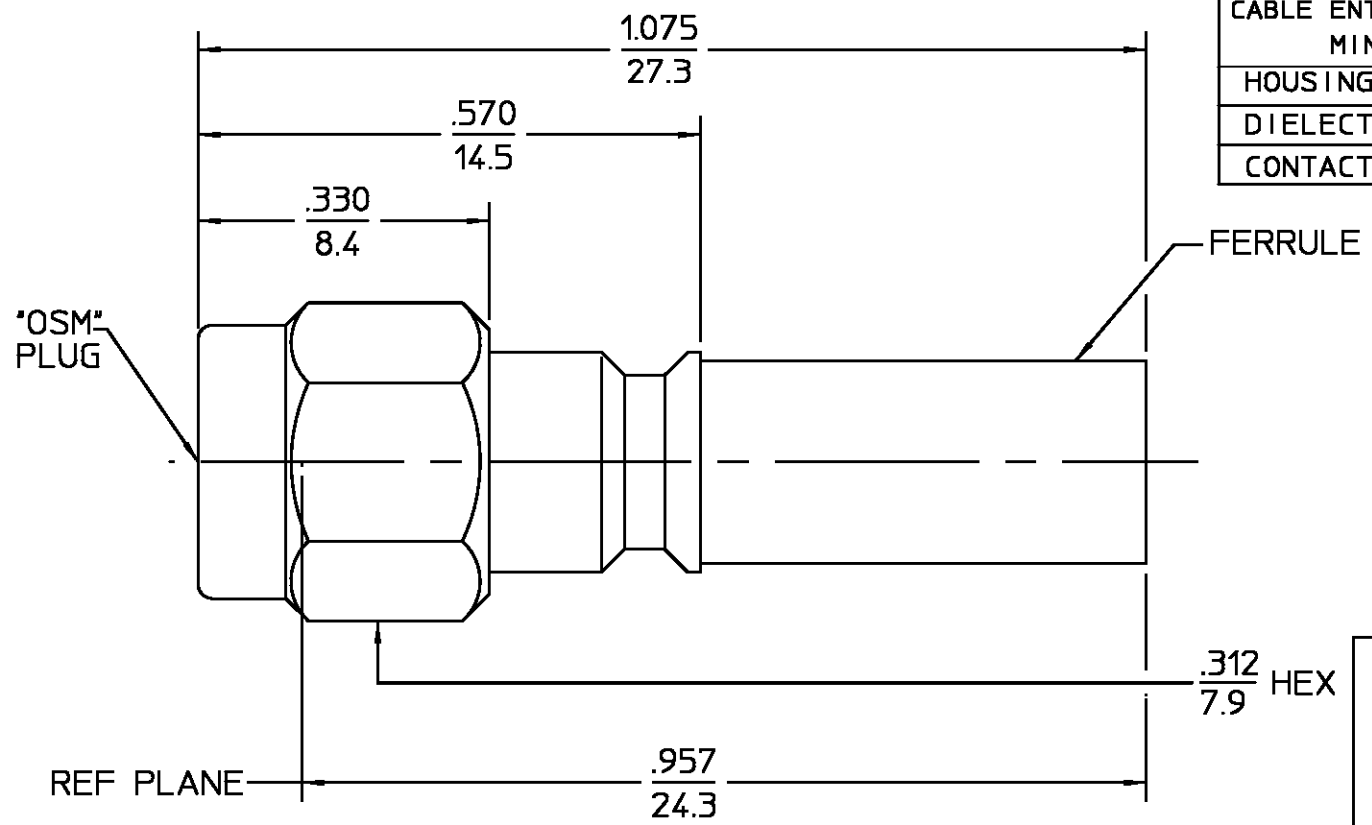

COMPONENT	MATERIAL	FINISH
HOUSING COUPLING NUT	STAINLESS STEEL PER ASTM-A484 AND ASTM-A582, TYPE 303	PASSIVATE PER QQ-P-35
DIELECTRIC	TFE FLUOROCARBON PER ASTM-D-1457	N/A
CENTER CONTACT	BERYLLIUM COPPER PER ASTM-B-196 OR ASTM-B-197, ALLOY C17300, CONDITION H	GOLD PLATE PER MIL-G-45204
RETAINING RING	BERYLLIUM COPPER PER ASTM-B-194, ALLOY C17200, CONDITION H	N/A
GASKET	SILICONE RUBBER PER ZZ-R-765	N/A
FERRULE	COPPER OR BRASS ALLOY ROCKWELL F65 MAXIMUM	GOLD PLATE PER MIL-G-45204

ELECTRICAL	MECHANICAL	ENVIRONMENTAL
Nominal Impedance (Ohms) <u>50</u>	Interface Dimensions MIL-STD-348A, Fig. 310-1	Temperature Rating <u>-65 TO +165°C</u>
Frequency Range (GHz) DC to <u>12.4</u>	Recommended Mating Torque <u>7-10 IN-LBS</u>	Vibration MIL-STD-202, Method 204, Condition D
Volt Rating (VRMS MAX) @ Sea Level <u>335</u>	Mating Characteristics: Insertion (MAX Lbs) <u>N/A</u>	Shock MIL-STD-202, Method 213, Condition I
VSWR <u>1.15 + 0.01f(GHz)</u>	Withdrawal (MIN Oz) <u>N/A</u>	Thermal Shock MIL-STD-202, Method 107, Condition B, Except High Temp +85°C
Insertion Loss (dB MAX) <u>.06 √f(GHz)</u>	Force to Engage and Disengage (In-Lbs MAX) <u>2</u>	Moisture Resistance MIL-STD-202, Method 106
RF Leakage (dB MIN) <u>-60</u>	Center Contact Captivation Axial (Lbs) <u>6</u>	Corrosion - MIL-STD-202, Method 101, Condition B, 5% salt spray
Corona, 70,000 Ft (VRMS MIN) <u>250</u>	Radial (In-Oz) <u>N/A</u>	
Dielectric Withstanding Voltage (VRMS MIN) @ Sea Level <u>1,000</u>	Cable Retention Axial Force (Lbs) <u>45</u>	
Contact Resistance (Milliohms MAX) Center Contact <u>3.0</u>	Torque (In-Oz) <u>N/A</u>	
Outer Contact <u>2.0</u>	Weight (Grams) <u>TBD</u>	
Cable to Housing <u>0.5</u>		
RF High Potential @ Sea Level (VRMS MIN @ 5 MHz) <u>670</u>		
LR.(Megohms MIN) <u>5,000</u>		

.XXX = in
XX.X = mm (REF)

UNLESS OTHERWISE SPECIFIED DIMENSIONS ARE IN INCHES	DRAWN BY K.LE	DATE 9-13-96	AMP Incorporated 140 Fourth Avenue Waltham, MA 02451-7599	
	CHECKED BY			
FRAC. ± 1/64	DEC. ± .005	ANGLES ± 1°	APPD BY <i>RAC</i> 11/5/96	
These drawings and specifications are the property of M/A COM Interconnect Div. and shall not be reproduced or copied or used in whole or in part as the basis for the manufacture or sale of item(s) without written permission.			USE ASSY PROCEDURE 408-04934 NO. A.P. (20-515)	
			TITLE "OSM" STRAIGHT CABLE PLUG-CRIMP ATTACHMENT	
SIZE B		CODE IDENT NO. 26805	2031-8162-92	REV 01 ₀
SCALE 5:1		SHEET 1 OF 1		