

REVISIONS			
REV	DESCRIPTION	DATE	APPROVED
01 ₀	RELEASED	12/21/93	<i>D. Comello</i>

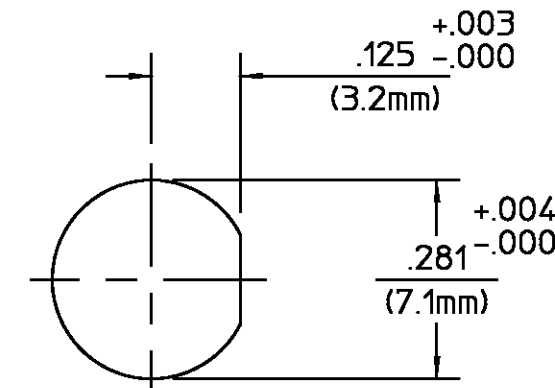

RECOMMENDED MOUNTING HOLE

HOUSING CLAMP NUT MOUNTING NUT LOCKWASHER	STAINLESS STEEL PER ASTM-A484 AND ASTM- A582, TYPE 303	PASSIVATE PER ASTM A380
SLEEVE	STAINLESS STEEL PER ASTM-A484 AND ASTM- A582, TYPE 303	GOLD PLATE PER MIL-G-45204 OVER NICKEL PLATE PER QQ-N-290
DIELECTRIC	TFE FLUOROCARBON PER ASTM-D-1457	N/A
DIELECTRIC	NYLON	N/A
CENTER CONTACT	BERYLLIUM COPPER PER ASTM B 196, ALLOY C17300, COND H	GOLD PLATE PER MIL-G-45204 OVER COPPER PLATE PER MIL-C-14550
FERRULE	SOFT COPPER ALLOY	GOLD PLATE PER MIL-G-45204
O-RING	SILICONE RUBBER PER ZZ-R-765	N/A
COMPONENT	MATERIAL	FINISH

CABLE ENTRY DIAMETER MINIMUM	
FERRULE	.099
SLEEVE	.036
DIELECTRIC	.021
CONTACT	.021

UNLESS OTHERWISE SPECIFIED
DIMENSIONS ARE IN INCHES
TOLERANCE ON
FRAC. DEC. ANGLES
± 1/64 ± .005 ± °

These drawings and specifications are the property of Omni Spectra Incorporated and shall not be reproduced or copied or used in whole or in part as the basis for the manufacture or sale of item(s) without written permission.

DRAWN BY *D. Comello* DATE 12/21/93
CHECKED BY
APPD BY *D. Comello* 12/21/93

USE ASS'Y PROCEDURE

408-04925
NO. AP. (20-536)

AMP Incorporated
140 Fourth Avenue
Waltham, MA 02451-7599

AMP

TITLE
SMA BULKHEAD FEEDTHRU CABLE JACK
SOLDER ATTACH. M39012/59-3006 CAT.A

SIZE B	CODE IDENT NO. 26805	2034-8006-92	REV 01 ₀
-----------	-------------------------	--------------	------------------------

SCALE 5:1 SHEET 1 OF 1

- NOTES:
- DESIGNED FOR USE WITH RG-178/U CABLE
 - CAPTURED CENTER CONTACT