

THIS DRAWING IS UNPUBLISHED.		RELEASED FOR PUBLICATION	
© COPYRIGHT - By -		ALL RIGHTS RESERVED.	
HOUSING CAP COUPLING NUT	STAINLESS STEEL PER ASTM-A484 AND ASTM- A582, TYPE 303	PASSIVATE PER QQ-P-35	
DIELECTRIC	TFE FLUOROCARBON PER ASTM-D-1457	N/A	
CENTER CONTACT	BERYLLIUM COPPER PER ASTM-B-196 OR ASTM-B-197, ALLOY C17300, CONDITION H	GOLD PLATE PER MIL-G-45204	
RETAINING RING	BERYLLIUM COPPER PER ASTM-B-194, ALLOY C17200, CONDITION H	N/A	
GASKET	SILICONE RUBBER PER ZZ-R-765	N/A	
FERRULE	COPPER OR BRASS ALLOY ROCKWELL F65 MAXIMUM	GOLD PLATE PER MIL-G-45204	
COMPONENT	MATERIAL	FINISH	

REVISIONS					
P	LTR	DESCRIPTION	DATE	DWN	APVD
	B	REV PER ECO 16-018488	07JUN07	CT	PR

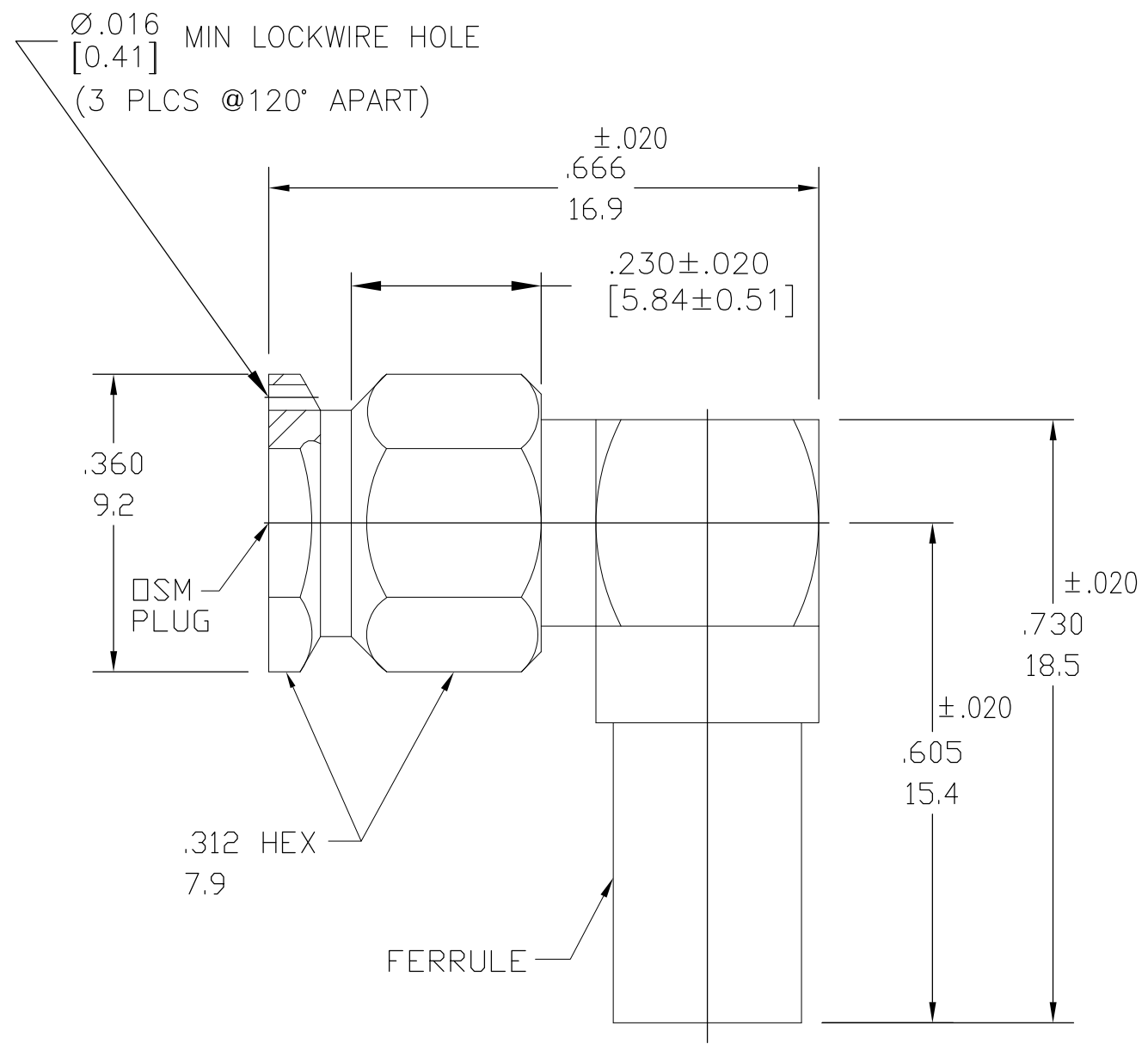

1. CAPTURED CENTER CONTACT

1052167-1
PART NO.

DESIGNED FOR USE WITH RG-58/U CABLE ENTRY DIAMETER MINIMUM	
SLEEVE	.202
HOUSING	.121
CONTACT	.041 SLOT

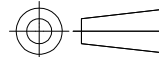
THIS DRAWING IS A CONTROLLED DOCUMENT.		DWN P. YEAGER 05JUN2007	 TE Connectivity			
DIMENSIONS: INCHES [mm]		CHK D. WILSON 07JUN07				
TOLERANCES UNLESS OTHERWISE SPECIFIED:		APVD D. WILSON 07JUN07	NAME OSM RIGHT ANGLE CABLE PLUG SOLDER ATTACHMENT M39012/56-3021 CAT B			
 0 PLC ± - 1 PLC ± - 2 PLC ± - 3 PLC ± .005 [0.13] 4 PLC ± - ANGLES ± 1°		PRODUCT SPEC -	RESTRICTED TO -			
MATERIAL SEE TABLE		FINISH SEE TABLE	APPLICATION SPEC -	SIZE A3	CAGE CODE 00779	DRAWING NO C-1052167
CUSTOMER DRAWING			WEIGHT 0.000000	SCALE 5:1	SHEET 1 OF 1	REV B