

THIS DRAWING IS UNPUBLISHED. RELEASED FOR PUBLICATION N/A, N/A  
 © COPYRIGHT N/A BY TYCO ELECTRONICS CORPORATION. ALL RIGHTS RESERVED.

LOC		DIST		REVISIONS			
P	LTR	DESCRIPTION	DATE	DWN	APVD		
DF	X0						
		O	RELEASED	9-02	JMK	JL	

COMPONENT	MATERIAL	FINISH
HOUSING CAP COUPLING NUT	STAINLESS STEEL PER ASTM-A-484 OR ASTM-A-582 TYPE 303	PASSIVATED PER ASTM-A-380
DIELECTRIC	PTFE FLUOROCARBON PER ASTM-D-1457	-
CENTER CONTACT	BRASS PER ASTM-B-16 HALF HARD	GOLD PLATED PER ASTM-B-488
GASKET	SILICONE RUBBER PER ZZ-R-765	-
FERRULE	COPPER OR BRASS ALLOY, ROCKWELL F65 MAX	GOLD PLATED PER ASTM-B-488
RETAINING RING	BERYLLIUM COPPER PER ASTM-B-194 ALLOY C17200, CONDITION H	-

ENVIRONMENTAL	
TEMPERATURE RATING:	-65°C TO +165°C
VIBRATION:	MIL-STD-202, METHOD 204, CONDITION D
SHOCK:	MIL-STD-202, METHOD 213, CONDITION 1
MOISTURE RESISTANCE:	MIL-STD-202, METHOD 106
CORROSION:	MIL-STD-202, METHOD 101, CONDITION B. 5% SALT SPRAY
THERMAL SHOCK:	MIL-STD-202, METHOD 107, CONDITION B EXCEPT HIGH TEMP 85°C

MECHANICAL	
INTERFACE DIMENSIONS:	MIL-STD-348A FIG. 310.1
RECOMMENDED MATING TORQUE:	7-10 IN-LBS
FORCE TO ENGAGE & DISENGAGE (IN-LBS MAX):	2.0
WEIGHT (GRAMS):	TBD
MATING CHARACTERISTICS:	INSERTION (MAX LBS): N/A WITHDRAWAL (MIN OZ): N/A
CABLE RETENTION:	AXIAL FORCE (LBS): 40 MIN TORQUE (IN-OZ): N/A
CENTER CONTACT CAPTIVATION:	AXIAL (LBS): 6.0 RADIAL (IN-OZ): N/A

ELECTRICAL	
NORMAL IMPEDANCE (OHMS):	50
FREQUENCY RANGE (GHz):	DC TO 12.4
VOLT RATING @ SEA LEVEL (VRMS MAX):	335
VSWR:	1.15+.02f(GHz)
INSERTION LOSS: (dB MAX):	.06 $\sqrt{f(\text{GHz})}$
RF LEAKAGE (dB MIN):	-60 @ 2-3 GHz
CORONA 70,000 FT (VRMS MIN):	250
DIELECTRIC WITHSTANDING VOLTAGE (VRMS MIN) AT SEA LEVEL:	1000
I.R. (MEGOHMS MIN):	5,000
RF HIGH POTENTIAL AT SEA LEVEL (VRMS MIN @ 5 MHz):	670
CONTACT RESISTANCE (MILLIOHMS MAX):	CENTER CONTACT: 4.0 OUTER CONTACT: 2.0 CABLE TO HOUSING: 0.5

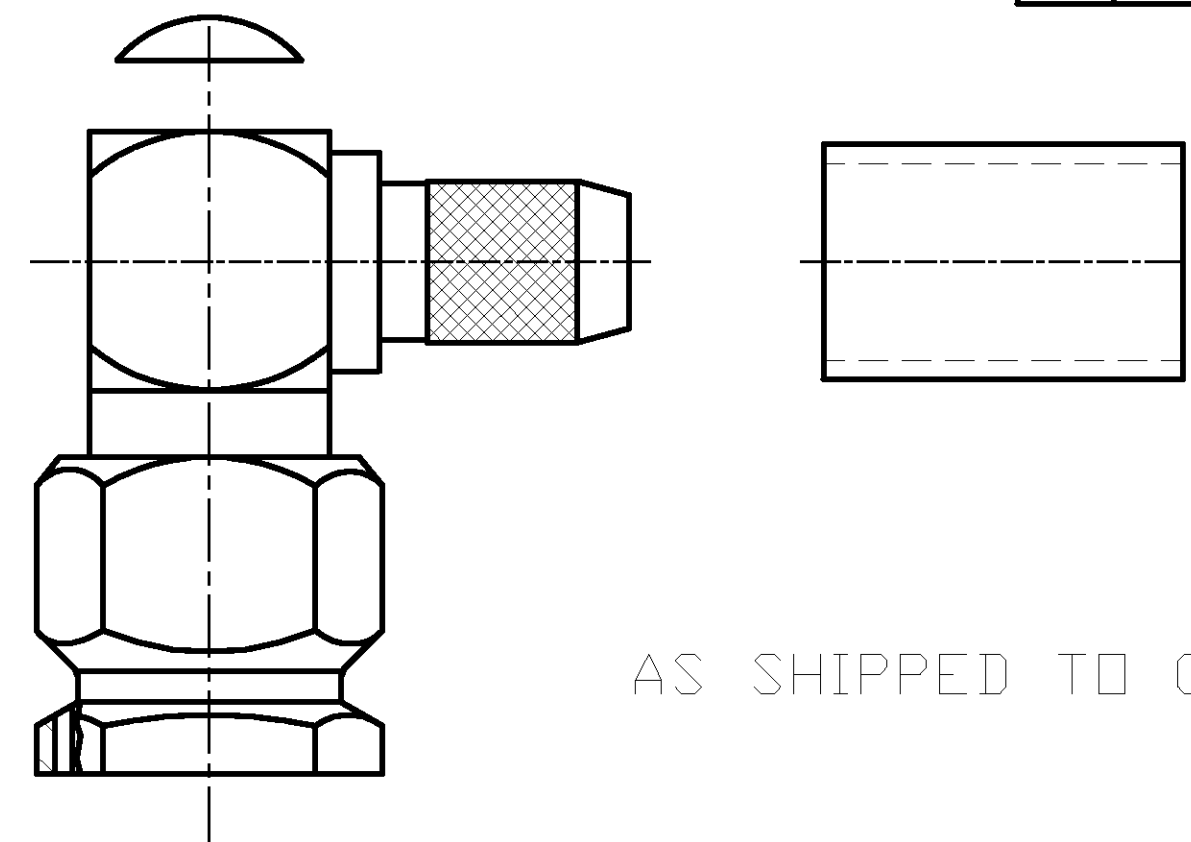

AS SHIPPED TO CUSTOMER

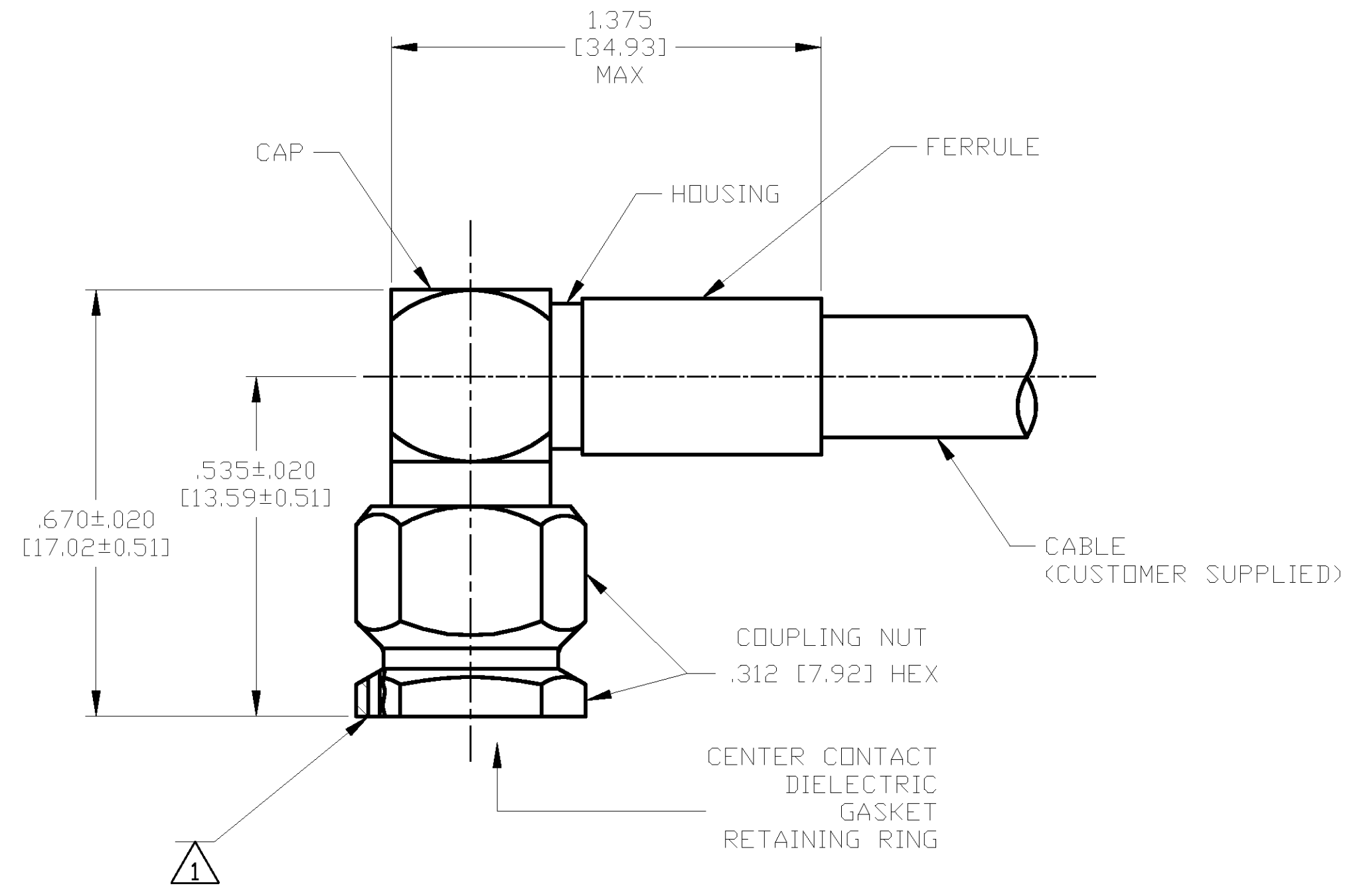

ASSEMBLED VIEW

1  $\phi$ .018 [0.46] LOCKWIRE HOLE, 3 PLACES EQUALLY SPACED.

DESIGNED TO USE RG-58/U OR EQUIVALENT CABLE ENTRY DIAMETER MIN	HOUSING: .121 [3.07]
	CONTACT SLOT: .041 [1.04]
	FERRULE: .202 [5.13]

THIS DRAWING IS A CONTROLLED DOCUMENT.	
DIMENSIONS: INCHES [mm]	TOLERANCES UNLESS OTHERWISE SPECIFIED:
$\phi$	0 PLC ± -
	1 PLC ± -
	2 PLC ± -
	3 PLC ± .005 [0.13]
	4 PLC ± -
	ANGLES ± -
MATERIAL SEE TABLE	FINISH SEE TABLE

DWN J. KAISER 9/24/02	Tyco Electronics Corporation Harrisburg, PA 17105
CHK J. LIPPERT 10-18-02	
APVD J. LIPPERT 10-18-02	NAME SMA RIGHT ANGLE CABLE PLUG-CRIMP ATTACHMENT (M39012/56-3029) CAT C
PRODUCT SPEC	SIZE A2
APPLICATION SPEC 408-4846	CAGE CODE 00779
WEIGHT TBD	DRAWING NO 1052177
CUSTOMER DRAWING	RESTRICTED TO -
SCALE 5:1	SHEET 1 OF 1
	REV 0

1052177

1052177-1  
PART NO.