

THIS DOCUMENT IS THE PROPERTY OF KEYSTONE ELECTRONICS CORP. AND SHALL NOT BE REPRODUCED, DISTRIBUTED OR USED AS A BASIS FOR MANUFACTURE WITHOUT PRIOR WRITTEN PERMISSION FROM KEYSTONE ELECTRONICS CORP.

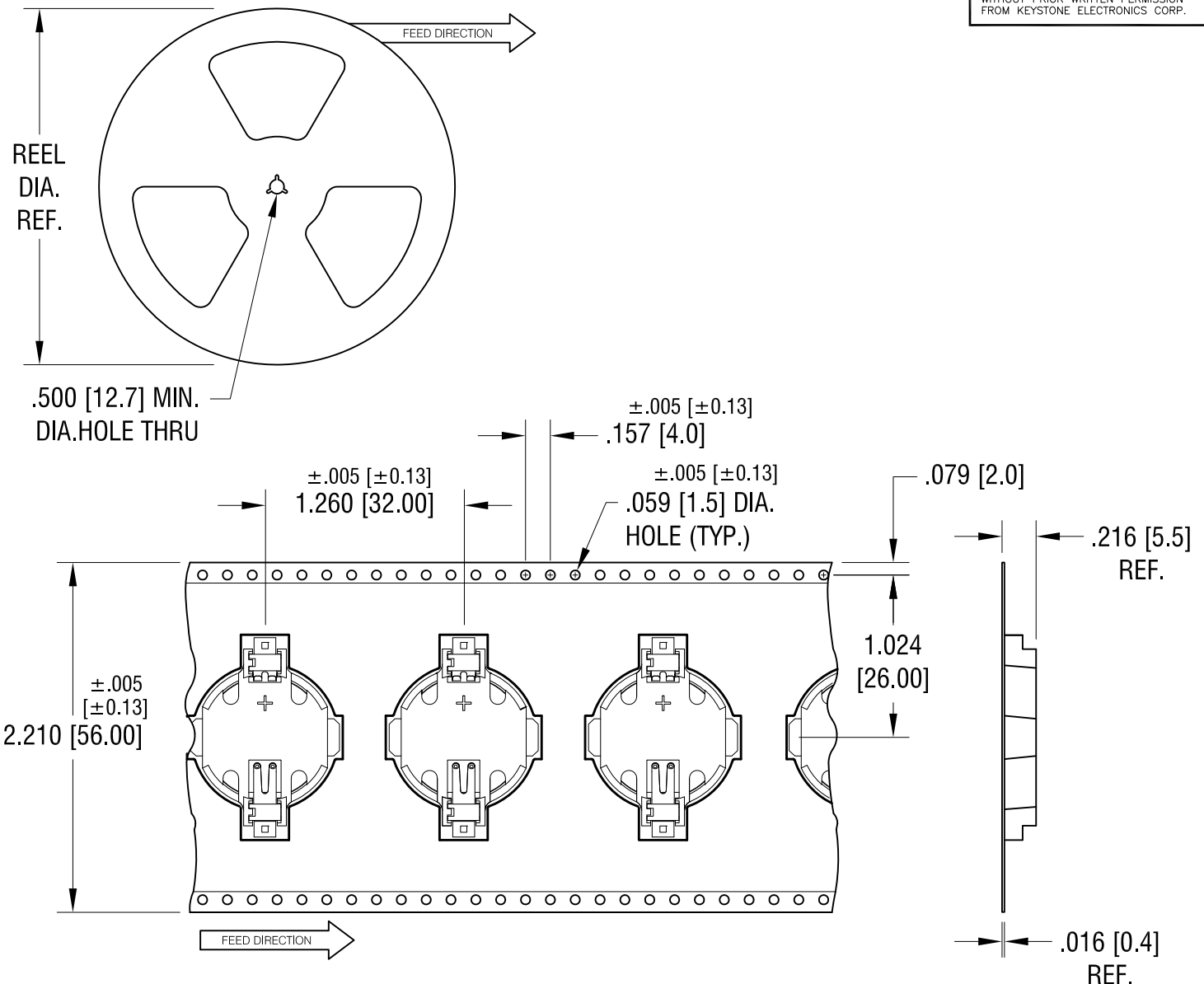

NOTES:

TAPE AND REEL SPECIFICATIONS:

1. TAPE:
 MAT'L - ALL CONDUCTIVE POLYSTYRENE CARRIER
 ANSI/EIA-481 STANDARD
 2.21 [56.0] WIDE; 1.26 [32] PITCH
2. REEL:
 13.0 [330.2] DIA. 400 PIECES OF
 PART NO. 1057 (REV. H) PER REEL.

11.06.14	CHANGE AS PER ECN14-115	B
6.10.13	TAPE WIDTH WAS 44mm CHANGE AS PER ECN 13-045	A
DATE	DESCRIPTION	REV.

KEYSTONE ELECTRONICS CORP.			
www.keyelco.com • ASTORIA, N.Y. 11105-2017 • Tel (718) 956-8900			
PART NAME			
2032mm SM COIN CELL HOLDER ON TAPE			
MATERIAL			
AS NOTED			
FINISH		DRN BY	DATE
AS NOTED		NT	5.28.13
		APP'D	SCALE
		LN	1X
TOLERANCES	INCH [MM]	CODE	DWG NO.
DECIMAL	± .015 [± 0.38]	C	1057TR
ANGULAR	± 1°		
UNLESS OTHERWISE SPECIFIED			

DATE	DESCRIPTION	REV.
6.04.13	CHANGE AS PER ECN 13-043	A
7.19.13	CHANGE AS PER ECN 13-058	B
7.24.13	CHANGE AS PER ECN 13-060	C
9.17.13	CHANGE AS PER ECN 13-072	D
10.24.13	CHANGE AS PER ECN 13-103	E
1.30.14	CHANGE AS PER ECN 14-014	F
3.10.14	CHANGE AS PER ECN 14-025	G
10.23.14	CHANGE AS PER ECN 14-110	H

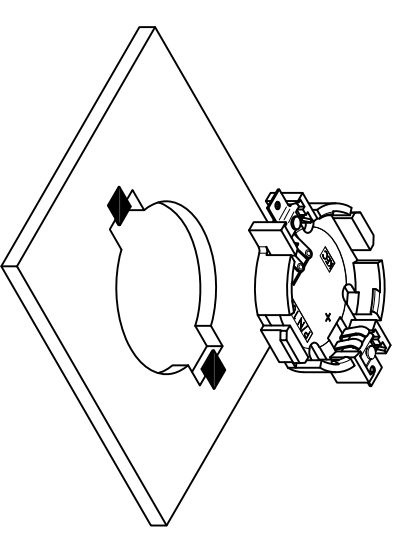
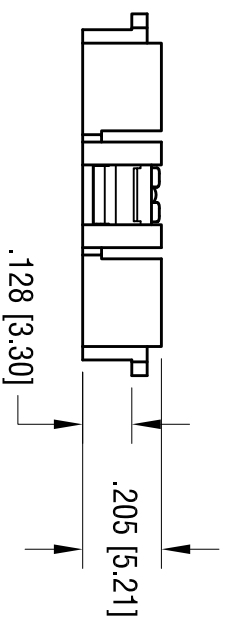
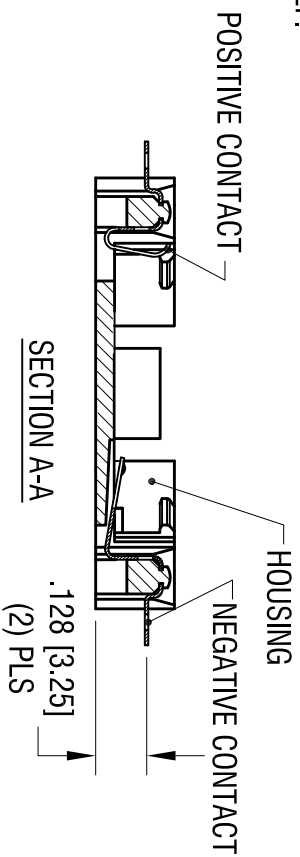
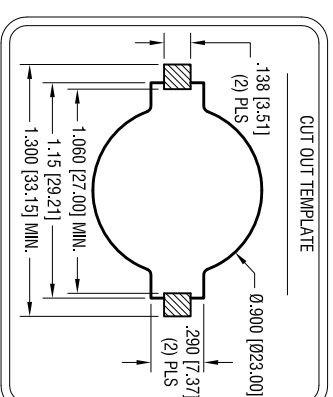
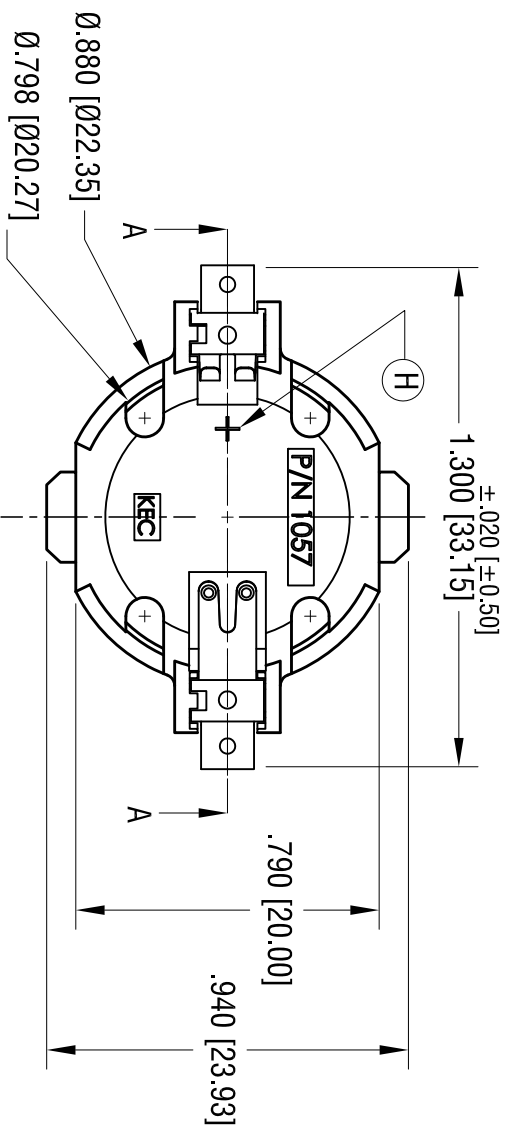

ACTUAL SIZE

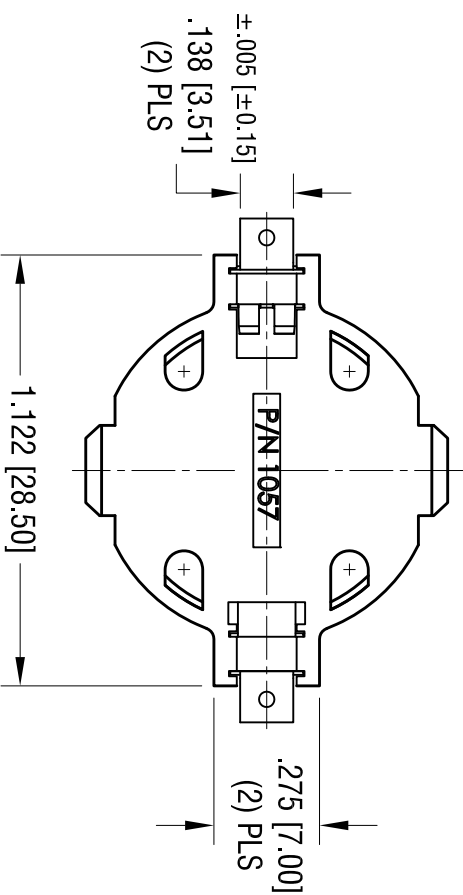

- NOTES:
1. BASE:
MAT'L - GLASS FILLED LCP UL 94V-0, NATURAL
 2. CONTACTS:
MAT'L - .009 [0.23] THK PHOSPHOR BRONZE
FINISH: GOLD FLASH, OVER NICKEL PLATING

KEYSTONE ELECTRONICS CORP.

www.keystecorp.com • ASTORIA, N.Y. 11105-2017 • Tel (718) 956-8900

PART NAME

2032 BATTERY HOLDER, SMT

MATERIAL

AS NOTED

FINISH

AS NOTED

TOLERANCES	INCH	[MM]	CODE	DWG NO.
DECIMAL	± .010	[± 0.25]	C	1057
ANGULAR	± 1°			

THIS DOCUMENT IS THE PROPERTY OF KEYSTONE ELECTRONICS CORP. AND SHALL NOT BE REPRODUCED, DISTRIBUTED OR USED AS A BASIS FOR MANUFACTURE WITHOUT PRIOR WRITTEN PERMISSION FROM KEYSTONE ELECTRONICS CORP.

DRN BY	DATE
NT	5.28.13

App'd LN SCALE 2X