

ASSEMBLY P/N	LENGTH (METERS)	TOLERANCE (METERS)
1064152101	1.0	+0.2/-0.0
1064152102	2.0	+0.2/-0.0
1064152103	3.0	+0.2/-0.0
1064152104	4.0	+0.2/-0.0
1064152105	5.0	+0.25/-0.0
1064152106	6.0	+0.25/-0.0
1064152107	7.0	+0.25/-0.0
1064152108	8.0	+0.25/-0.0
1064152110	10.0	+0.30/-0.0
1064152115	15.0	+0.30/-0.0
1064152120	20.0	+0.40/-0.0
1064152130	30.0	+0.60/-0.0
1064152150	50.0	+1.00/-0.0
1064152199	100.0	+2.00/-0.0

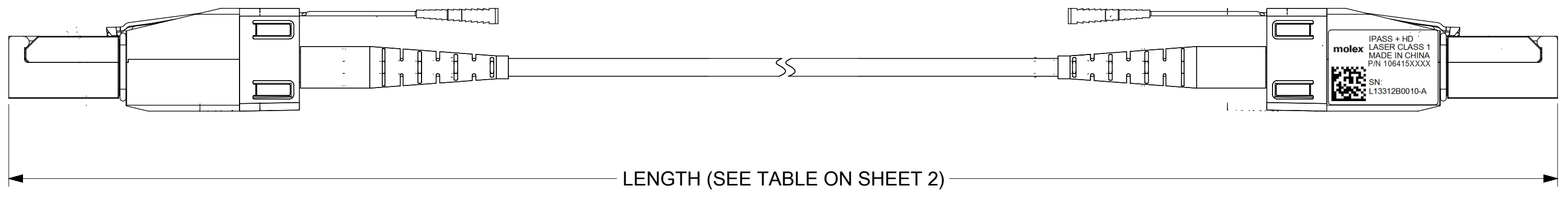

JUMPER VIEW
SCALE 1.5:1

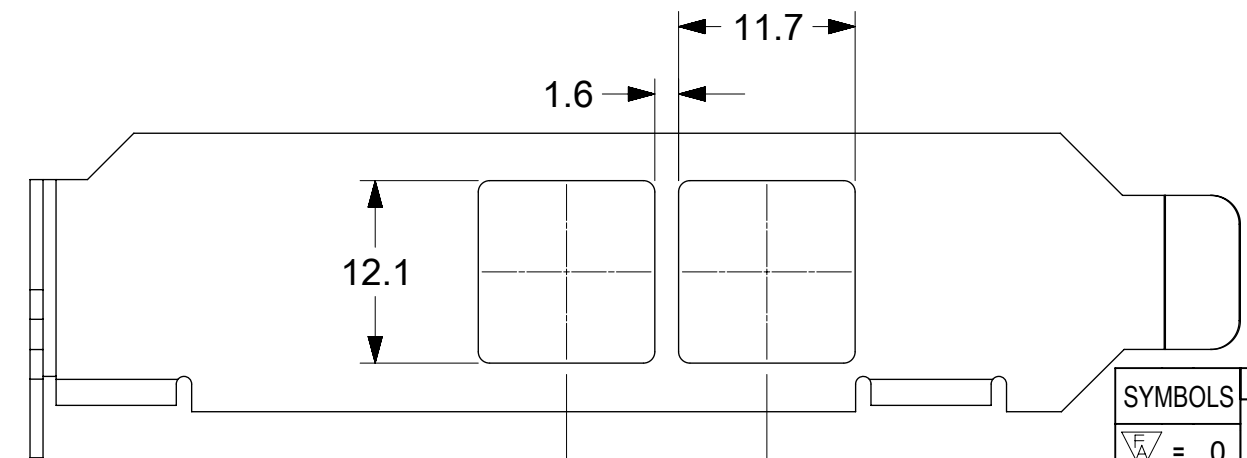
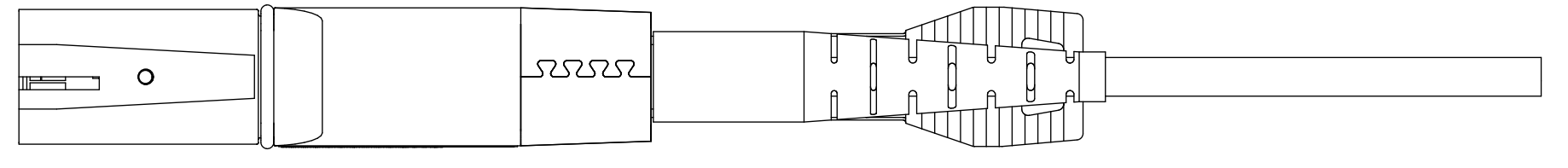
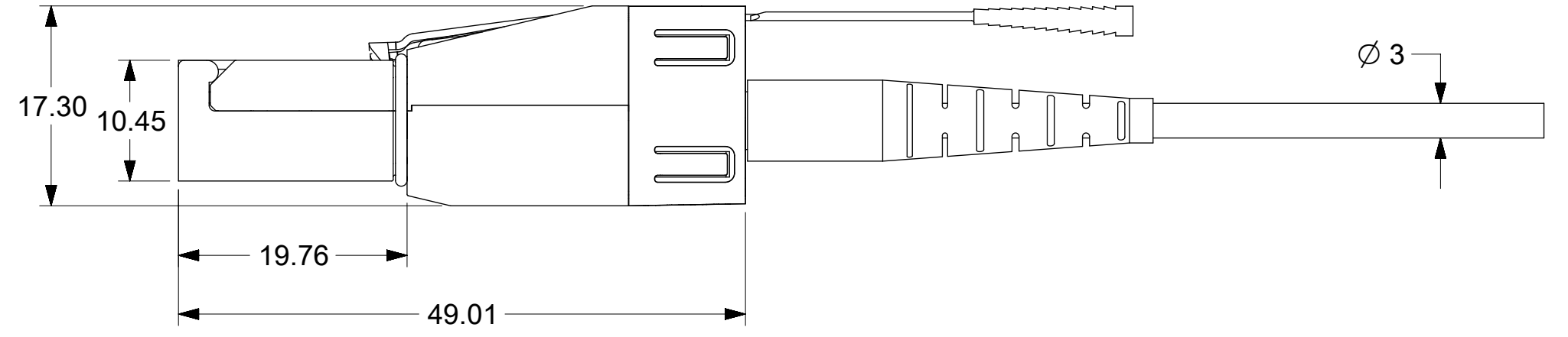
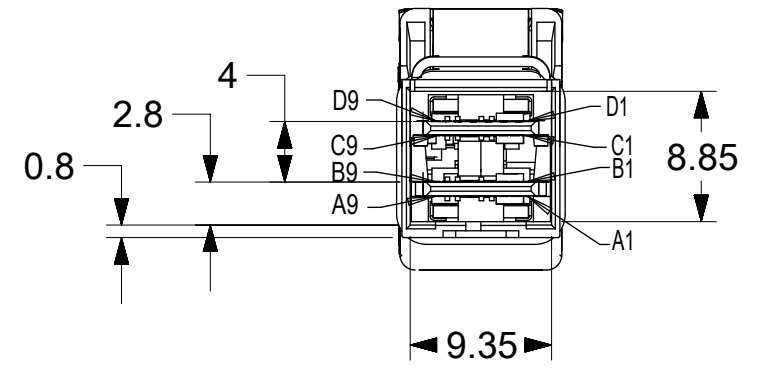
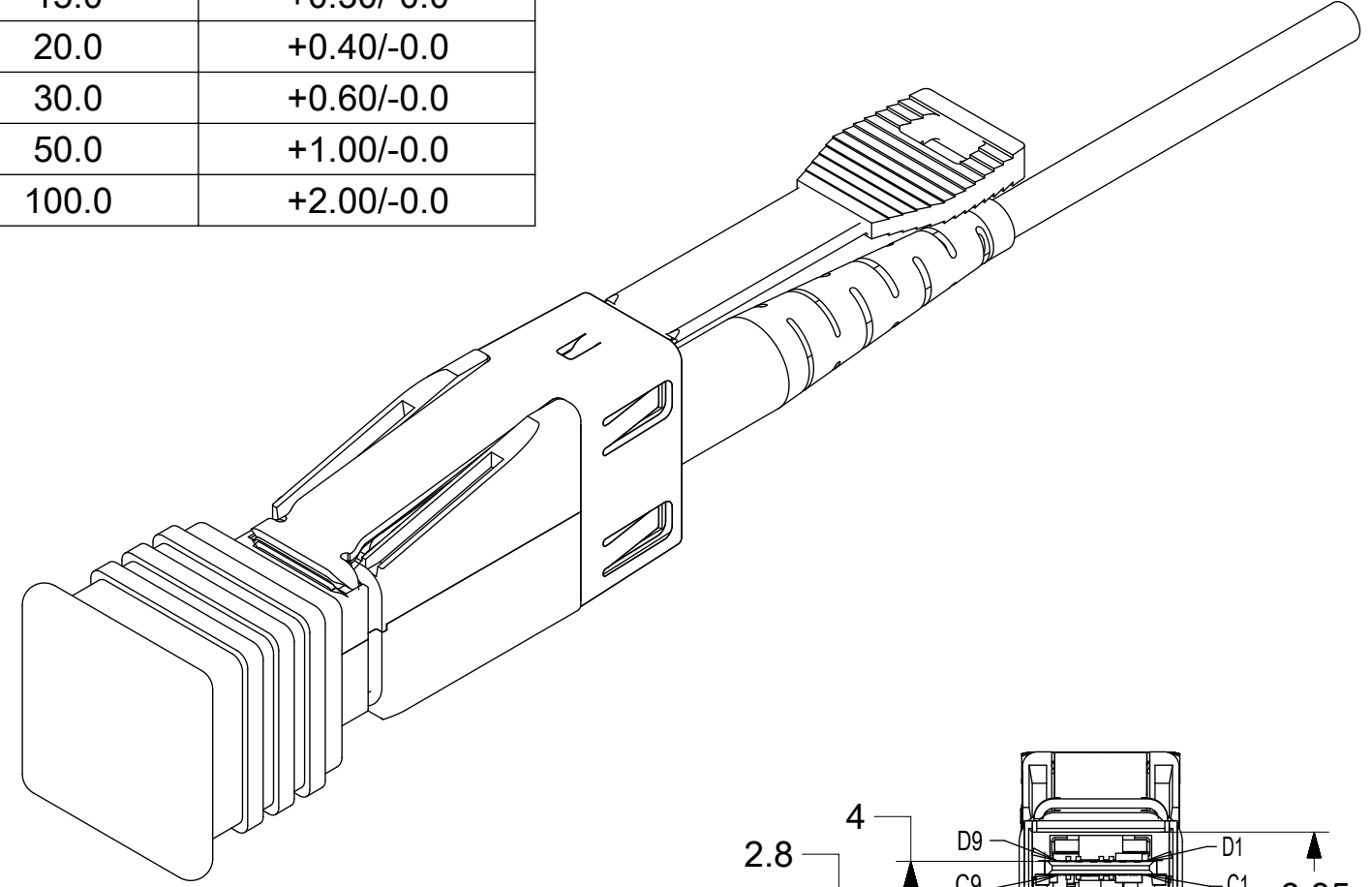
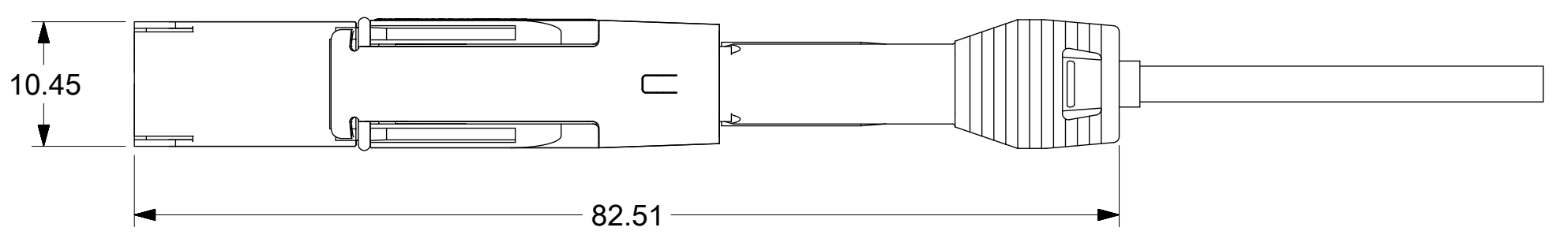

SHIELDED INTEGRATED HD CONNECTOR MINIMUM PITCH

SCALE 2:1

- NOTES:
- MATERIALS:
BACKSHELLS - ZINC DIECAST WITH NICKEL PLATING.
LATCH - STAINLESS STEEL.
PULL - MOLDED PLASTIC, 279C (BLUE)
 - CABLE TYPE PLENUM (OFNP) WITH 8 MULTIMODE FIBERS, MINIMUM BEND RADIUS 25mm, FIBER CORE 50/125um OM3, CABLE JACKET COLOR-AQUA, DIAMETER 3.2mm MAX.
 - ELECTRICAL AND MECHANICALS PER SFF-8644 AND SFF-8636
 - PLUG MATES TO 1X1, 1X2 AND 1X4 RECEPTACLE - EMI HOUSING ASSEMBLY SERIES.
 - THIS PRODUCT COMPLIES WITH EU RoHS PER DIRECTIVE 2011/65/EU AND ITS SUBSEQUENT AMENDMENTS, INCLUDING THE DIRECTIVE EU 2015/863.

THIS DRAWING CONTAINS INFORMATION THAT IS PROPRIETARY TO MOLEX ELECTRONIC TECHNOLOGIES, LLC AND SHOULD NOT BE USED WITHOUT WRITTEN PERMISSION										
SYMBOLS		DIMENSION UNITS	SCALE	CURRENT REV DESC:						
▽ = 0	mm	1:1	EC NO: 622328							
▽ = 0	GENERAL TOLERANCES (UNLESS SPECIFIED)		DRWN: IGUMIN 2019/08/12							
▽ = 0	ANGULAR TOL ± °		CHK'D: SSUN23 2019/08/16							
▽ = 0	4 PLACES ±		APPR: SSUN23 2019/08/16							
▽ = 0	3 PLACES ±		INITIAL REVISION:							
▽ = 0	2 PLACES ±		DRWN: MAGHAYERE01 2016/03/04							
▽ = 0	1 PLACE ±		APPR: IGUMIN 2016/03/16							
▽ = 0	0 PLACES ±		DRAFT WHERE APPLICABLE MUST REMAIN WITHIN DIMENSIONS		THIRD ANGLE PROJECTION	DRAWING	SERIES	MATERIAL NUMBER	CUSTOMER	SHEET NUMBER
▽ = 0			⊕	C-SIZE	106415	SEE TABLE				1 OF 1

molex

IPASS+ HD AOC, S-TYPE

PRODUCT CUSTOMER DRAWING

DOCUMENT NUMBER	DOC TYPE	DOC PART	REVISION
1064152105	PSD	000	A3