

SD

1074-4

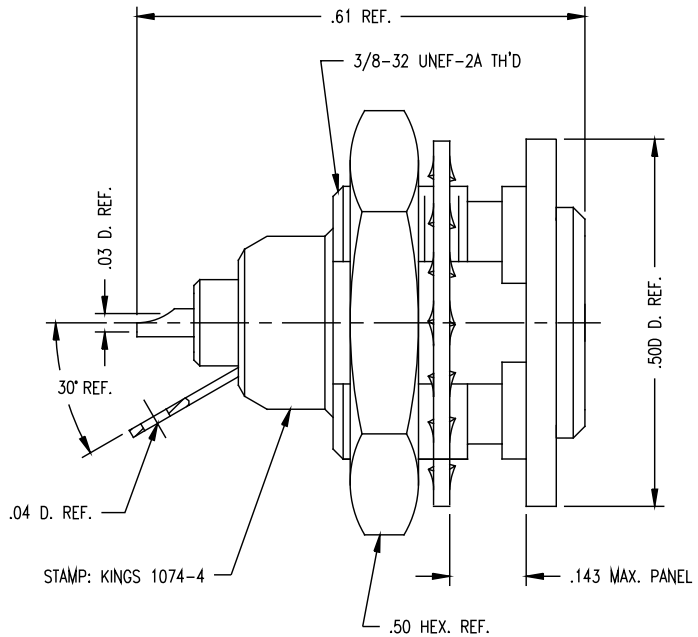

- NOTES:
- INTERFACE PER N.B.S. DWG. ND-549.
 - MATERIALS:
 - INSULATOR: TEFLON, ASTM-D-4894
 - OUTER CONTACT } BER. COP., ASTM-B-196
 - CENTER CONTACT }
 - OUTER BODY: BLACK DELRIN 150
 - LOCKWASHER: PHOS. BRONZE, ASTM-B-103
 - ALL OTHER PARTS: BRASS, ASTM-B16
 - FINISHES:
 - CONTACTS: HARD GOLD PLATE PER MIL-G-45204
 - ALL OTHER METAL PARTS: KINGS TARNISH RESISTANT NICKEL FINISH (TR-5)
 - ELECTRICAL CHARACTERISTICS:
 - NOMINAL IMPEDANCE: 50 OHMS
 - VOLTAGE RATING: 500 VRMS

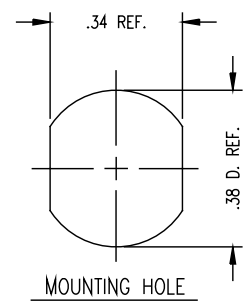

SD

REVISIONS	
ISSUE	CHANGES
9	CN 36553 C REDRAWN KH 10/11/95
10	CN 39039 C JPK 02/26/04

1074-4SD

SCALE 6:1	
APPROX SURFACE AREA	
USED ON	
REF:	
RCPT, BKHD, ISO. GRD., K-LOC	
DRAWN KH	DATE 10/11/95
DESIGN LI	DATE 10/12/95
APPR.	DATE

KINGS
ELECTRONICS CO., INC.
ROCK HILL, SOUTH CAROLINA 29730

1074-4