

THIS DOCUMENT IS THE PROPERTY OF
KEYSTONE ELECTRONICS CORP. AND
SHALL NOT BE REPRODUCED, DISTRIBUTED
OR USED AS A BASIS FOR MANUFACTURE
WITHOUT PRIOR WRITTEN PERMISSION
FROM KEYSTONE ELECTRONICS CORP.

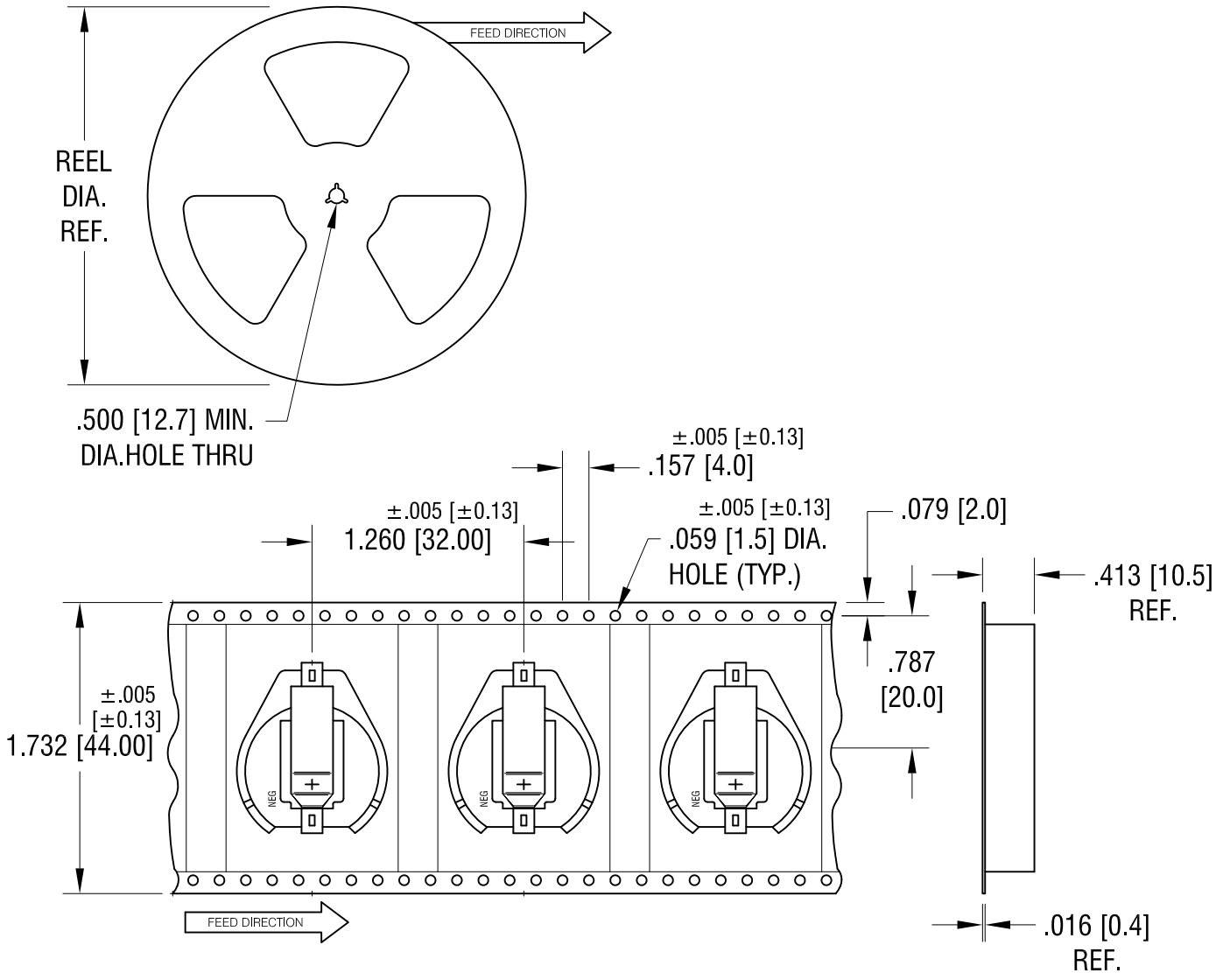

NOTES:

TAPE AND REEL SPECIFICATIONS:

1. TAPE:

MAT'L - ALL CONDUCTIVE POLYSTYRENE CARRIER
ANSI/EIA-481 STANDARD
1.732 [44.0] WIDE; 1.260 [32.0] PITCH

2. REEL:

13.0 [330.2] DIA. 200 PIECES OF
PART NO. 1081 PER REEL.

KEYSTONE ELECTRONICS CORP.			
www.keyelco.com • ASTORIA, N.Y. 11105-2017 • Tel (718) 956-8900			
PART NAME			
20mm SM COIN CELL HOLDER ON TAPE			
MATERIAL			
AS NOTED			
FINISH		DRN BY	DATE
AS NOTED		NT	3.19.09
		APP'D	SCALE
		LN	X
TOLERANCES	INCH	[MM]	CODE
DECIMAL	± .015	[± 0.38]	C
ANGULAR	± 1°		DWG NO.
UNLESS OTHERWISE SPECIFIED			1081TR

DATE	DESCRIPTION	REV.

MOUNTING DETAIL

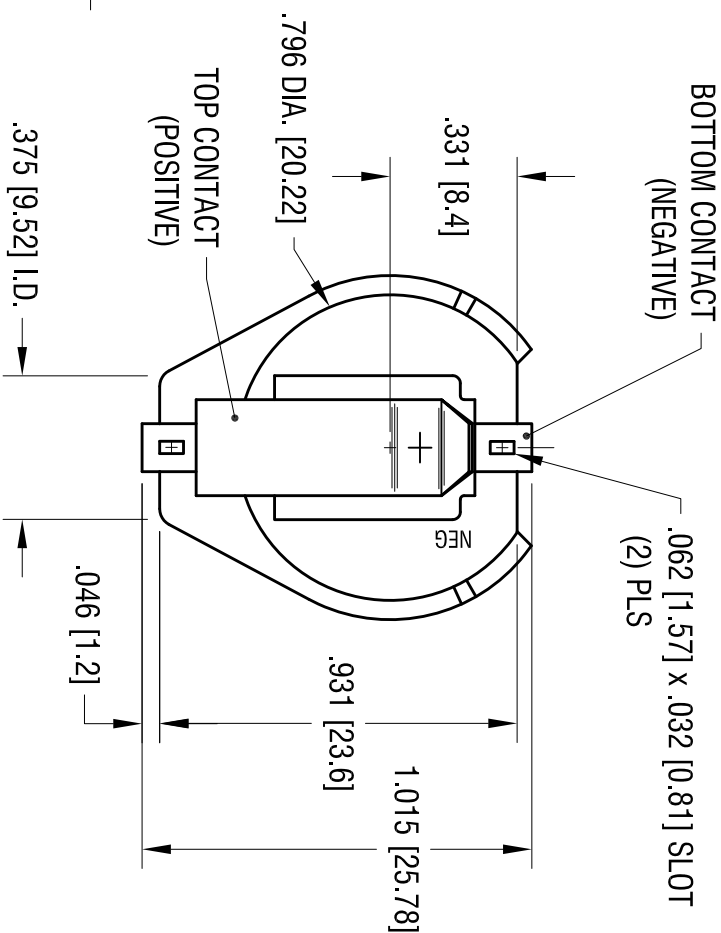
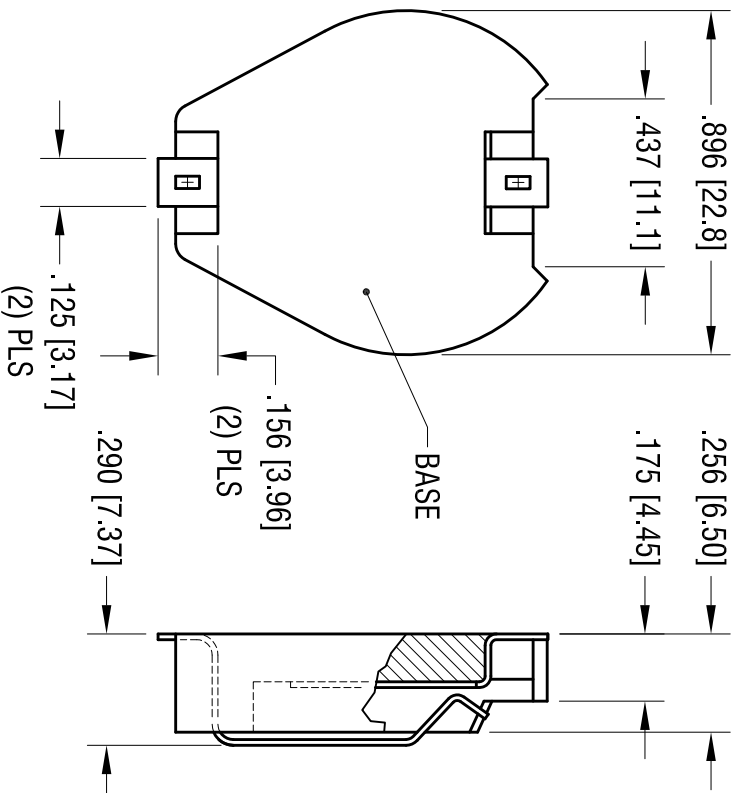
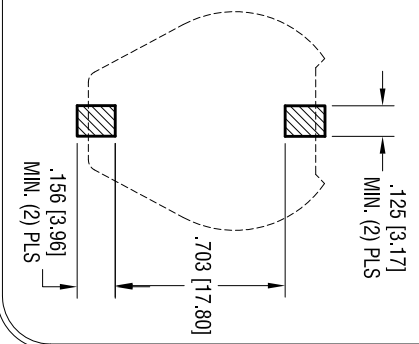

NOTES:

1. BASE:
MAT'L - HIGH TEMPERATURE NYLON (UL 94V-0)
COLOR BLACK
2. CONTACTS (TOP AND BOTTOM):
MAT'L - .015 [0.38] THK SPRING STEEL
FINISH: GOLD FLASH PLATE

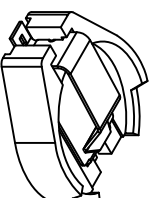

ACTUAL SIZE

THIS DOCUMENT IS THE PROPERTY OF KEYSTONE ELECTRONICS CORP. AND SHALL NOT BE REPRODUCED, DISTRIBUTED OR USED AS A BASIS FOR MANUFACTURE WITHOUT PRIOR WRITTEN PERMISSION FROM KEYSTONE ELECTRONICS CORP.

DATE	DESCRIPTION	REV.
8.12.11	CHANGE AS PER ECN 11-104	A

KEYSTONE ELECTRONICS CORP.

www.keystec.com • ASTORIA, N.Y. 11105-2017 • Tel (718) 956-8900

PART NAME

20mm BATTERY HOLDER, SMT

MATERIAL

AS NOTED

FINISH

AS NOTED

TOLERANCES	INCH	[MM]	CODE	DRN BY	DATE
DECIMAL	± .010	[± 0.25]	C	NT	3.19.09
ANGULAR	± 1°			LN	SCALE 2X
				App'D	
				DWG NO.	1081