

DATE	DESCRIPTION	REV.
6.28.22	CHANGE AS PER ECN 22-106 BASE MAT'L WAS HEAT RESISTANCE NYLON (UL94V-0) STANYL 46	A

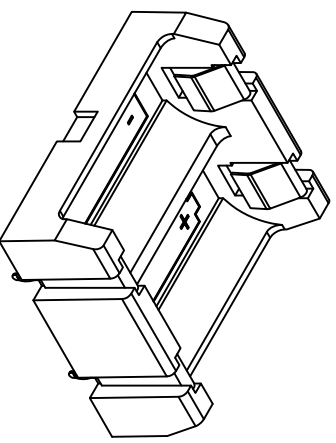
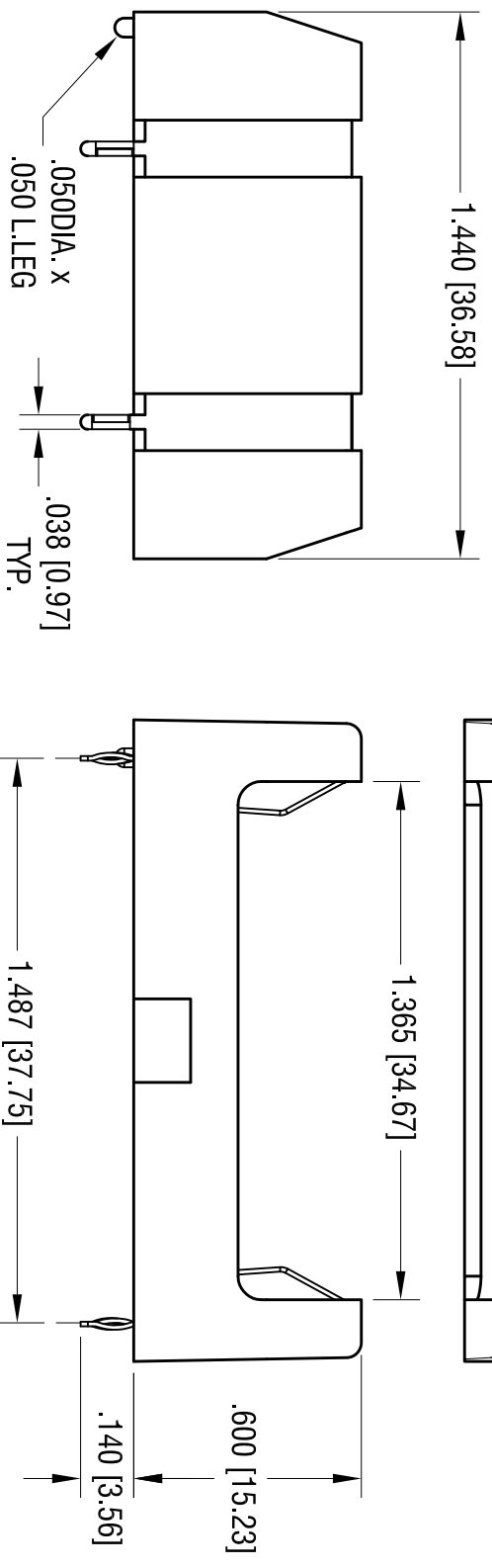
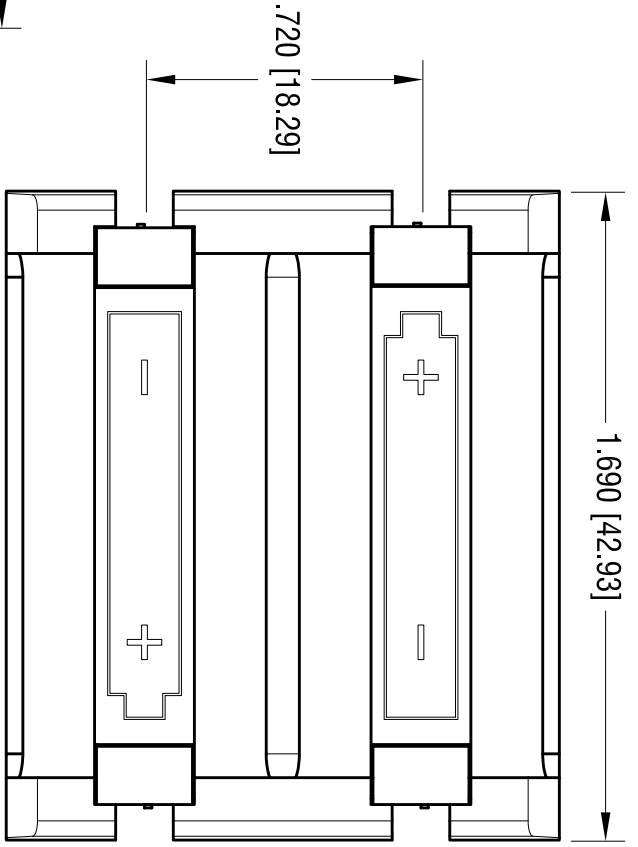
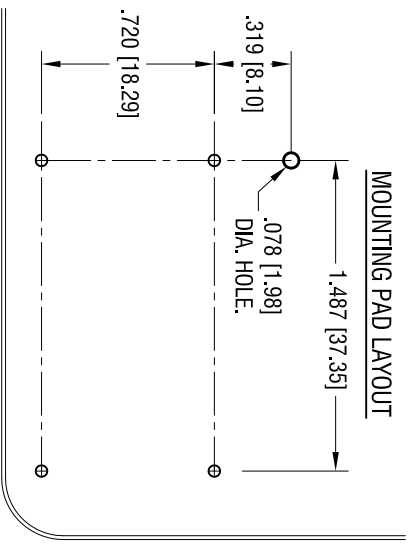

ACTUAL SIZE

KEYSTONE ELECTRONICS CORP.

www.keystec.com • ASTORIA, N.Y. 11105-2017 • Tel (718) 956-8900

PART NAME

THM BATTERY HOLDER, (2) 2/3A

MATERIAL

AS NOTED

FINISH

AS NOTED

DRN BY	DATE
NT	1.05.15
App'D	SCALE
RH	2X

- NOTE:
1. BASE:
MAT'L: PBT (GRAY COLOR)
 2. CONTACT:
MAT'L: .012 [0.30] THK STAINLESS STEEL
FINISH: TIN NICKEL PLATE.

THIS DOCUMENT IS THE PROPERTY OF
KEYSTONE ELECTRONICS CORP. AND
SHALL NOT BE REPRODUCED, DISTRIBUTED
OR USED AS A BASIS FOR MANUFACTURE
WITHOUT PRIOR WRITTEN PERMISSION
FROM KEYSTONE ELECTRONICS CORP.

TOLERANCES	INCH	[MM]	CODE	DWG NO.
DECIMAL	± .010	[±	C	1099
ANGULAR	± 1°]		