

**SILICON RECTIFIER**

**VOLTAGE RANGE 1000 Volts CURRENT 10 Amperes**

**FEATURES**

- \* High surge current capability
- \* Low leakage
- \* Low forward voltage drop
- \* High current capability
- \* Low lost

**MECHANICAL DATA**

- \* Case: Molded plastic black body
- \* Epoxy: Device has UL flammability classification 94V-0
- \* Lead: MIL-STD-202E method 208C guaranteed
- \* Mounting position: Any

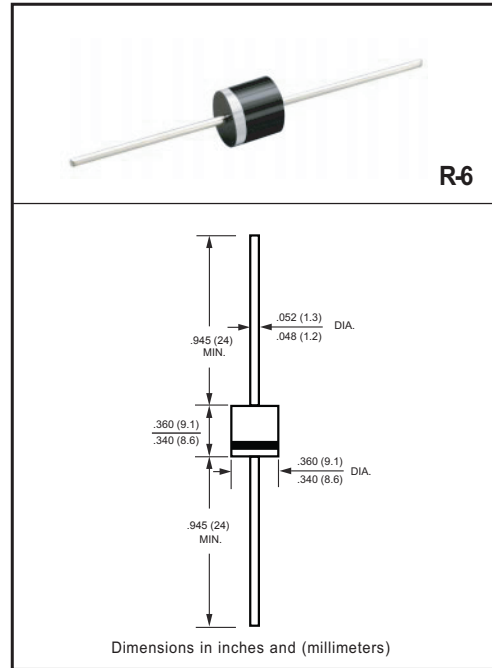

**MAXIMUM RATINGS AND ELECTRICAL CHARACTERISTICS**

Ratings at 25 °C ambient temperature unless otherwise specified.  
Single phase, half wave, 60 Hz, resistive or inductive load.  
For capacitive load, derate current by 20%.

**MAXIMUM RATINGS (@ TA=25 °C unless otherwise noted)**

RATINGS	SYMBOL	10A05	10A1	10A2	10A4	10A6	10A8	10A10	UNITS
Maximum Recurrent Peak Reverse Voltage	V <sub>RRM</sub>				1000				Volts
Maximum RMS Voltage	V <sub>RMS</sub>				700				Volts
Maximum DC Blocking Voltage	V <sub>DC</sub>				1000				Volts
Maximum Average Forward Rectified Current at TA = 50°C	I <sub>O</sub>				10				Amps
Peak Forward Surge Current I <sub>FM</sub> (surge): 8.3 ms single half sine-wave superimposed on rated load (JEDEC method)	I <sub>FSM</sub>				400				Amps
Typical Current Squared Time	i <sup>2</sup> T				664				A <sup>2</sup> S
Typical Thermal Resistance (Note 3)	R <sub>θJA</sub>				20				°C/W
Typical Thermal Resistance (Note 4)	R <sub>θJL</sub>				4				°C/W
Typical Thermal Resistance (Note 5)	R <sub>θJC</sub>				6				°C/W
Typical Junction Capacitance (Note 1)	C <sub>J</sub>				135				pF
Operating and Storage Temperature Range	T <sub>J</sub> , T <sub>STG</sub>				-55 to + 150				°C

**ELECTRICAL CHARACTERISTICS (@TA=25 °C unless otherwise noted)**

CHARACTERISTICS	SYMBOL	10A05	10A1	10A2	10A4	10A6	10A8	10A10	UNITS
Maximum Forward Voltage at 10A DC	V <sub>F</sub>				1.1				Volts
Maximum DC Average Reverse Current at Rated DC Blocking Voltage	@T <sub>A</sub> = 25°C				5				uAmps
	@T <sub>A</sub> = 150°C				2				mAmps
Maximum Full Load Reverse Current Average Full Cycle .375" (9.5mm) Lead Length at T <sub>L</sub> =75°C	I <sub>R</sub>				50				uAmps

- NOTES : 1. Measured at 1.0 MHz and applied average voltage of 4.0VDC  
 2. " ROHS compliant".  
 3. Thermal Resistance: At 9.5mm lead lengths,PCB mounted.  
 4. Thermal Resistance Junction to lead  
 5. Thermal Resistance Junction to dice

## RATING AND CHARACTERISTICS CURVES ( 10A05 THRU 10A10 )

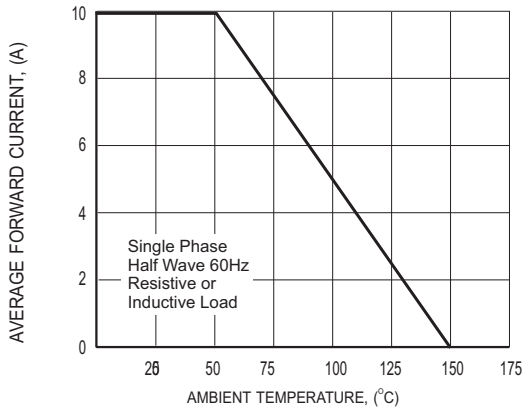

FIG.1 TYPICAL FORWARD CURRENT DERATING CURVE

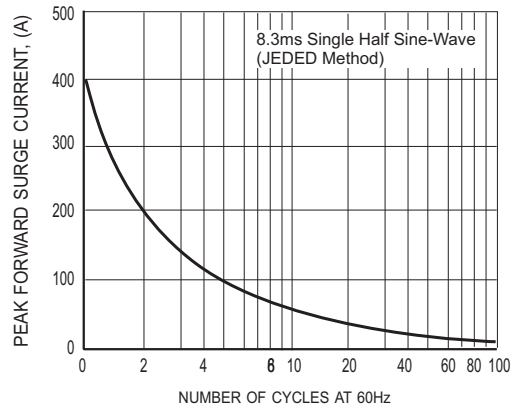

FIG.2 MAXIMUM NON-REPETITIVE FORWARD SURGE CURRENT

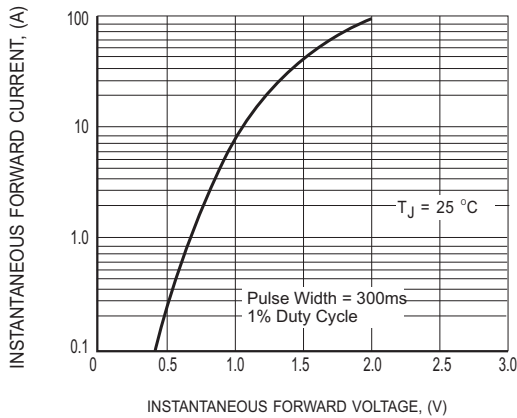

FIG.3 MAXIMUM INSTANTANEOUS FORWARD CHARACTERISTICS

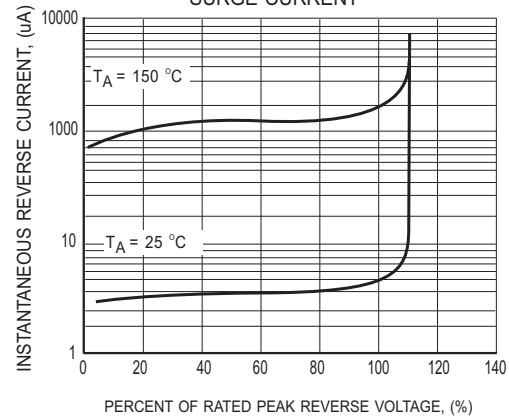

FIG.4 MAXIMUM REVERSE CHARACTERISTICS

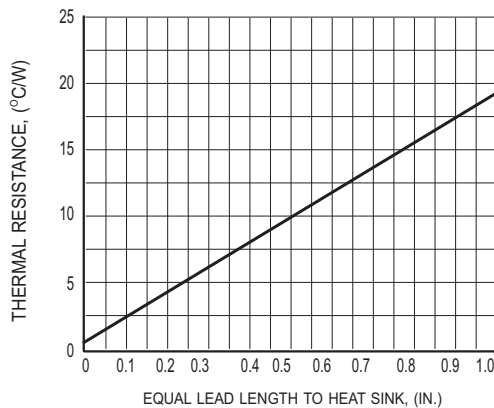

FIG.5 TYPICAL THERMAL RESISTANCE vs. LEAD LENGTH



## Attachment information about 10AX

### 1. Internal Circuit



### 2. Marking on the body

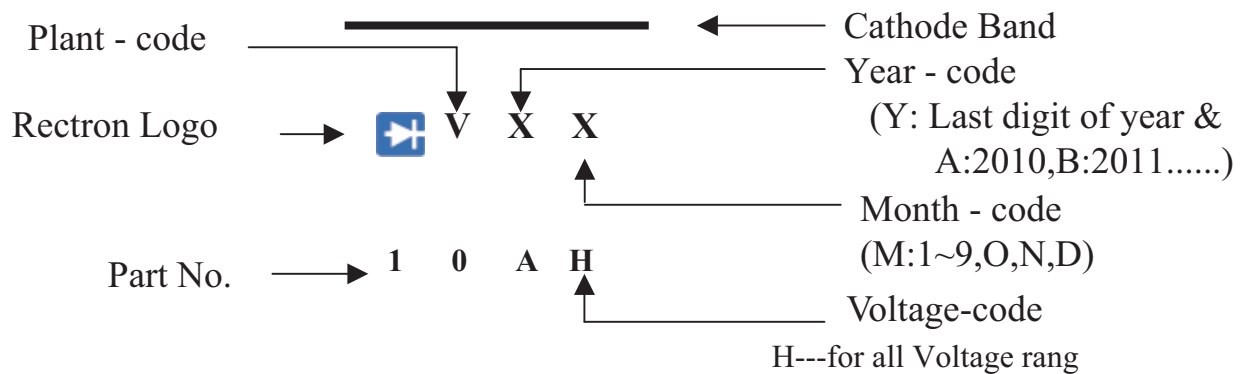

## PACKAGING OF DIODE AND BRIDGE RECTIFIERS

### BULK PACK

PACKAGE	PACKING CODE	EA PER BOX	INNER BOX SIZE (mm)	CARTON SIZE (mm)	EA PER CARTON	GROSS WEIGHT(Kg)
R-6/R-7	-B	200	300*73*40	347*320*271	4,800	12.93/14.57

### REEL PACK

PACKAGE	PACKING CODE	EA PER REEL	EA PER INNER BOX	COMPONENT SPACE (mm)	TAPE SPACE (mm)	REEL DIA (mm)	CARTON SIZE (mm)	EA PER CARTON	GROSS WEIGHT(Kg)
R-6/R-7	-T	800	800	9.5	52	330	355*350*335	3,200	9.72/9.91

### AMMO PACK

PACKAGE	PACKING CODE	REEL ( EA )	COMPONENT SPACE(mm)	TAPE SPACE (mm)	BOX SIZE (mm)	CARTON SIZE(mm)	CARTON ( EA )	GROSS WEIGHT (Kg)
R-6/R-7	-F	300	9.5	52	255*73*100	400*268*225	3,000	8.5/8.7