

# SQUARE FLANGE MOUNTED HIGH LOAD BEARING ASSEMBLY

PART NUMBERS: 11008-000, 11008-002, 11008-003, 11008-004

## Introduction

This accessory has a square flange on a sturdy cast aluminum base, a high load bearing and shaft, a flexible shaft coupling and an integral flange that accepts a Model H25D, H20DB or H38D encoder. The high load shaft is 5/8" diameter with flat. This high load bearing assembly has a flange mount for easy installation. It is used for encoder applications which are subject to high side loads which can reduce bearing life considerably. Encoder is ordered separately.



## Features

- Light weight cast aluminum
- Flange mount for easy installation
- Supports very high shaft loads
- Integral shaft coupling
- Fits three different encoder models

## SPECIFICATIONS

Encoder Model	Adapter	Hardware to mount encoder to accessory	PN to Order
H20D	N/R	Included	11008-003
H25D or H20D	N/R	Included	11008-000
H25D	N/R	Included	11008-002
H38D - UL	Included	Included	11008-004



**DIMENSIONS**  
All dimensions are in inches

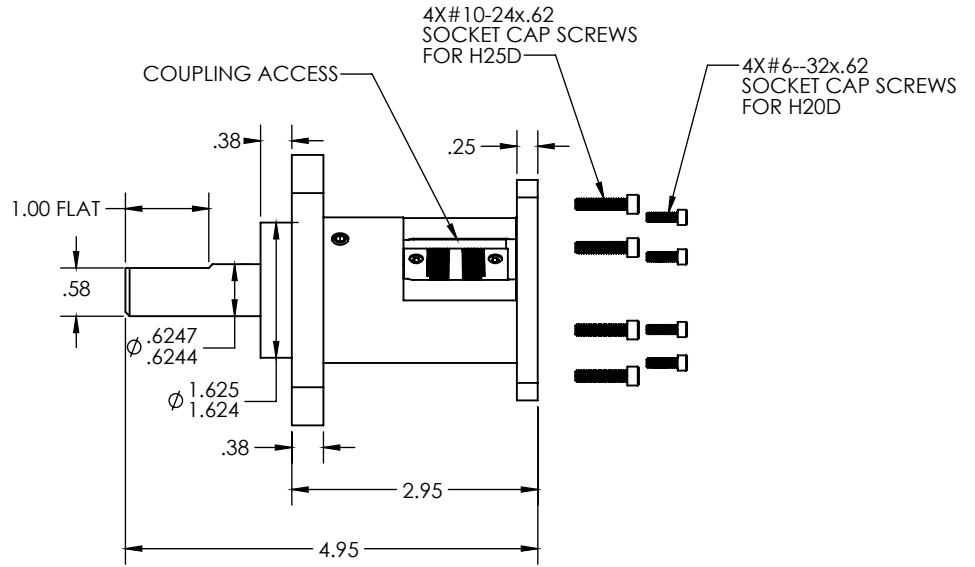
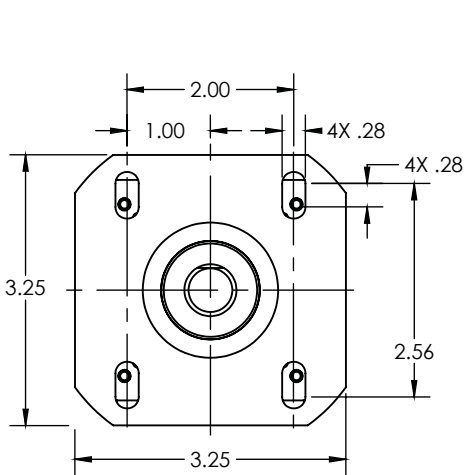

**11008-000**  
HIGH-LOAD BEARING  
ASSEMBLY INCLUDES HARDWARE  
FOR BOTH H25D AND H20D  
(SOLD SEPARATELY)

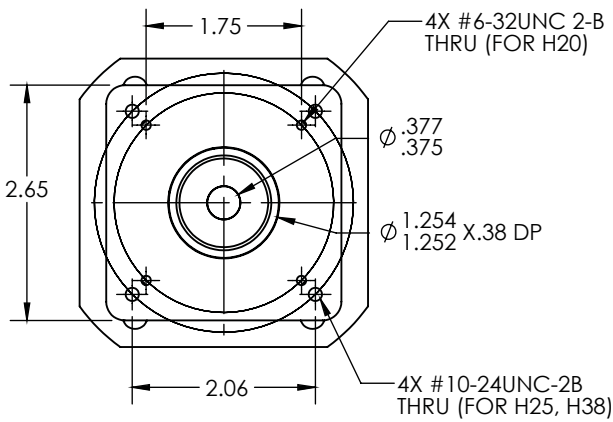

Bearing Life vs. Speed at Various Radial Loads

