

FOOT MOUNTED HIGH LOAD BEARING ASSEMBLY

PART NUMBERS: 11009-001, 11009-002, 11009-003

Introduction

This accessory has a NEMA 56C face on a sturdy cast aluminum base, a high load bearing and shaft, a flexible shaft coupling and an integral flange that accepts a Model H25D, H20DB or H38D encoder. The high load shaft is 5/8" diameter with 3/16 in. key slot. This high load bearing assembly has a built-in foot mount for easy installation. It is used for encoder applications which are subject to high side loads which can reducing bearing life considerably. Encoder is ordered separately.

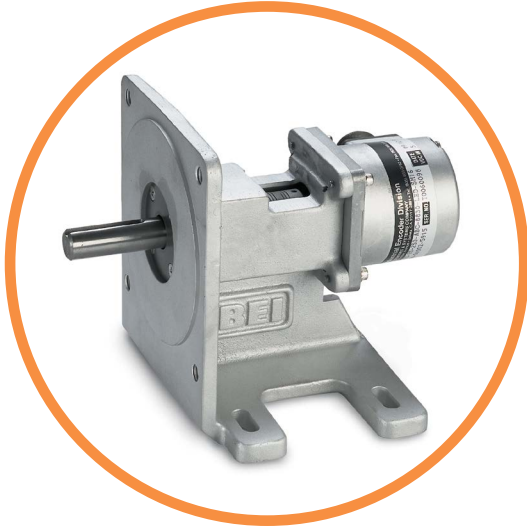

Features

- Compact size
- Foot mounting for stability
- Supports very high shaft loads
- Integral shaft coupling
- Easy installation
- Industry standard NEMA 56C face
- Fits three different encoder models

SPECIFICATIONS

Encoder Model	Adapter	Hardware to mount encoder to accessory	PN to Order
H20DB	N/R	Included	11009-002
H25D	N/R	Included	11009-001
H38 UL and CEN	Included	Included	11009-003



DIMENSIONS

Tolerance, unless otherwise noted:
All dimensions are in inches

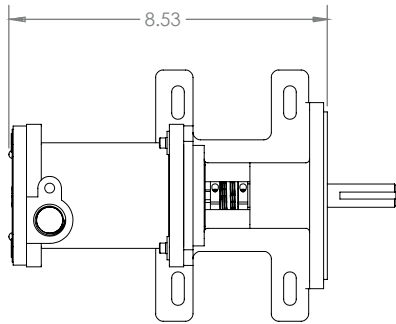
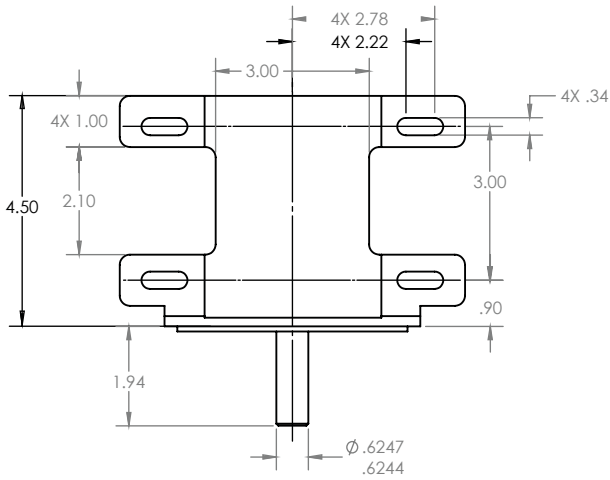
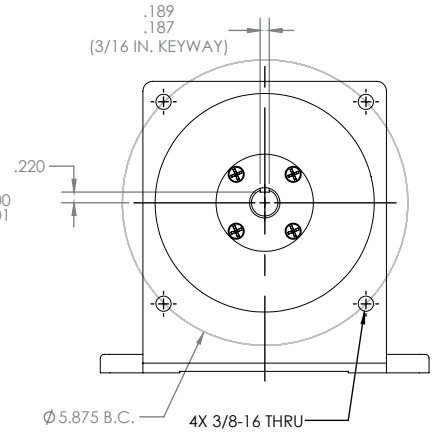
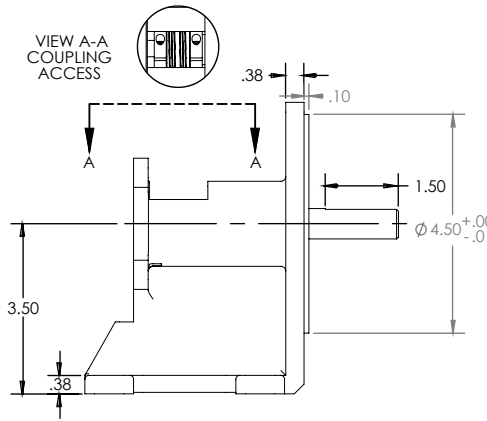
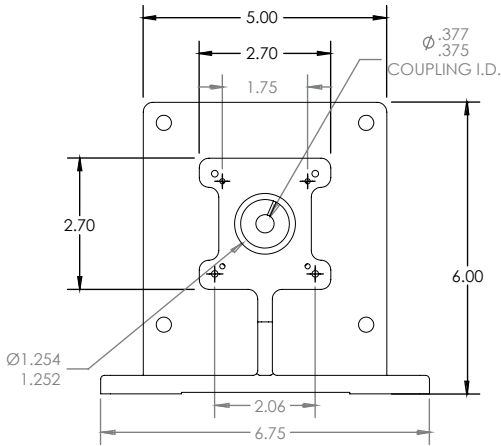

11009-003
HIGH LOAD ASSEMBLY
FOR H38 UL OR H38 CEN
(SOLD SEPARATELY)

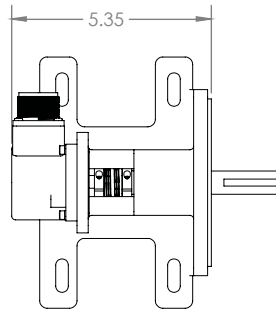

11009-002
HIGH LOAD ASSEMBLY
FOR H20 (SOLD
SEPARATELY)

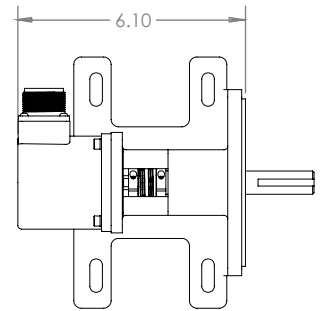

11009-001
HIGH LOAD ASSEMBLY
FOR H25 (SOLD
SEPARATELY)