



Control Knob Accessories

CONTROL KNOBS Ideally Suited for Encoder and Rotary Switches

FEATURES





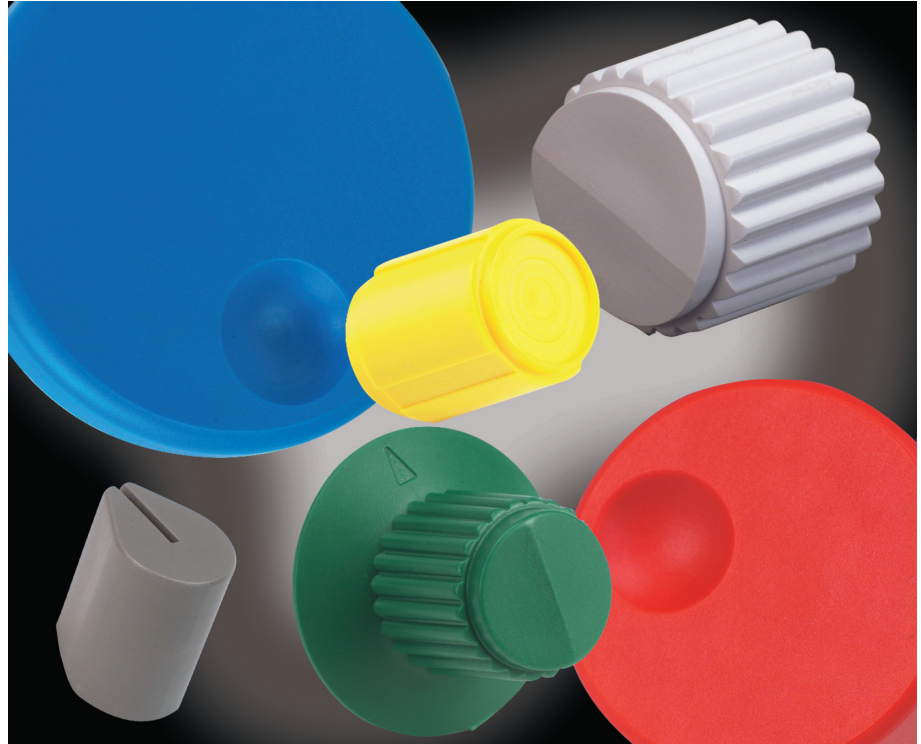

- Standard Fit for Grayhill Encoder and Rotary Switches
- Custom Materials, Styles, Colors and Markings Available
- Standard Black or Gray
- Choice of Spring Clip (Press-On) or Metal Insert with Set Screw Versions

Contact Grayhill for special design considerations

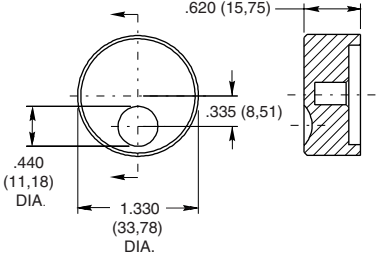

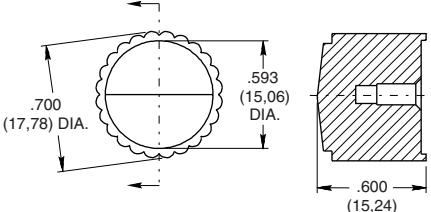
Optical and Mechanical Encoders

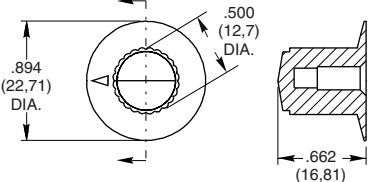
DIMENSIONS In inches (and millimeters)

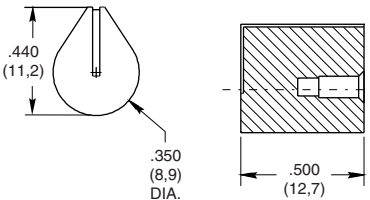
<p>Style 5013</p>  <p>Top View</p>  <p>Available in .250 Dia. Shaft only.*</p>	<p>Style 5014</p>  <p>Top View</p> 
<p>Style 5015</p>  <p>Top View</p> 	<p>Style 5017</p>  <p>Top View</p>  <p>Available in .125 and .157 (4mm) dia. shaft in spring clip (press-on) version only.*</p>

*See Ordering Information.

DIMENSIONS In inches (and millimeters)

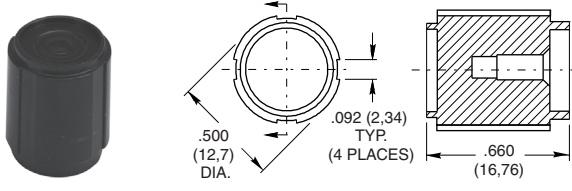
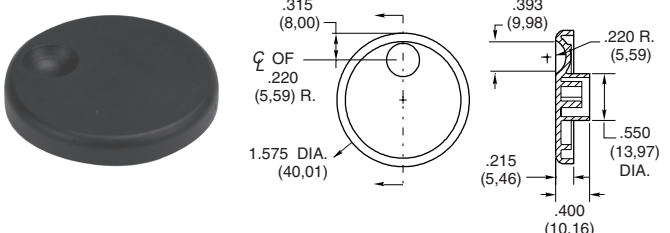
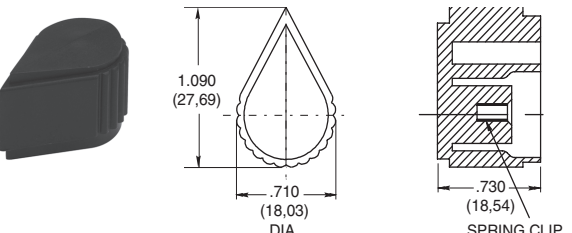
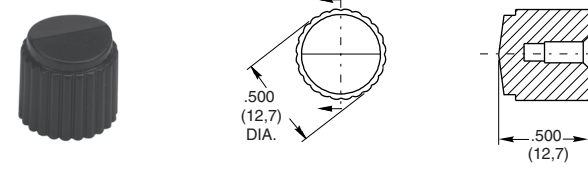
<p>Style 5019</p> 	<p>Style 5020</p>  <p>Available in ABS, .250 dia. shaft in spring clip (press-on). The locking clip is also available, requires a custom shaft.**</p>
<p>Style 5028</p> 	<p>Style 5029</p> 

*See Ordering Information.

**Contact Grayhill representative

ORDERING INFORMATION

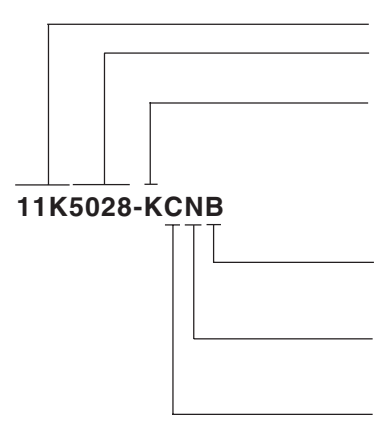

11K5028-KCNB

Series
Style*: 5013, 5014, 5015, 5017, 5019, 5020, 5028, 5029
 (see dimension drawings for style options)

Shaft Diameter:
J = .125 dia. shaft
E = .157 (4mm) dia. shaft
K = .250 dia. shaft

Knob Color:
B = Black
G = Gray

Material:
A = ABS (available on the styles 5017 and 5020 only)
N = Nylon

Version:
C = Spring Clip (press-on)
L = Locking Clip (available on the style 5020 only)
M = Metal Insert w/Set Screw(s)

Custom materials, styles and colors are available.

For prices and discounts, contact a local sales office or Grayhill.

Optical and Mechanical Encoders