

Series 11VR

11mm Panel Potentiometer

- Compact 11 mm package size
- Rotational life (15,000 cycles)
- Wide temperature range (-10°C to +70°C)
- Single and dual output options

Applications

- Consumer portable electronics
- Commercial appliances
- Instrument amplifiers and guitar effects
- Keyboards and synthesizers
- Communications equipment



Ordering Information

Series	Element	Terminal Configuration	Shaft Length	Shaft Trim	Mechanical Travel	Detent Option	Resistance Code	Resistance Taper
11VR	1	H	20	F	2	N	103	B1

Code	Spec.
X	Horizontal/Side Mount Bushingless, PC Pins, 10mm Height
H	Vertical/Rear Mount Thread Bushing, PC Pins
K	Vertical/Rear Mount Sleeve Bushing, PC Pins
Y	Horizontal/Side Mount Thread Bushing, PC Pins, 10mm Height
U	Vertical/Rear Mount Bushingless, PC Pins

Code	Spec.*
12	12.5 mm
15	15 mm
17	17.5 mm
20	20 mm
22	22.5 mm
25	25 mm
27	27.5 mm
30	30 mm

Code	Spec.
1	Single
2	Dual

Code	Spec.
B	Knurled (18 teeth)
F	Flatted

Code	Spec.
2	300°

Code	Spec.
N	No Detent
C	Center Detent

Code	Spec.**
A2	10% Log
A3	15% Log
B1	linear
C3	15% Antilog

Code	Spec.
502	5kΩ
103	10kΩ
203	20kΩ
503	50kΩ
104	100kΩ
254	250kΩ
504	500kΩ

* See shaft trim options for available lengths.

** Other JIS tapers are available. See charts.



Electrical Specifications

		Min	Typical	Max	Unit
Total Resistance Tolerance		-20	–	+20	%
Power Rating		–	+0.05	–	watt
Operating Voltage		–	–	+50 +20	VAC VDC
Residual Resistance		–	+30	–	Ω
Slider Noise		–	–	+100	mV
Tracking Error	Dual version only	-2	–	+2	dB
Insulation Resistance					
Single	500 VDC for 1 min.	+100	–	–	MΩ
Dual	250 VDC for 1 min	+100	–	–	MΩ
Dielectric Strength					
Single	500 VAC for 1 min., no arcing				
Dual	250 VAC for 1 min., no arcing				
Taper	Linear and audio options (see charts)				

Mechanical

Total Mechanical Travel	300° ± 5°
Operating Torque	30 to 200 gf-cm
Shaft Wobble	
Bushingsless	0.7 x L/20mm p-p max.; L = Shaft Length
With Bushing	0.7 x L/30mm p-p max.; L = Shaft Length
Shaft Push-Pull Strength	8 kgf for 3 sec.
Stop Strength	5 kgf-cm min.
Detent Position	150° ± 5°
Detent Torque	30 to 300 gf-cm
Rotational Life	15,000 cycles
Panel Nut Tightening Torque	10 kgf-cm
IP Rating	40
Mounting Hardware	One flat washer and one mounting hex nut supplied with bushing option
Packaging	Tray
Weight	3 grams

Environmental

		Min	Typical	Max	Unit
Operating Temperature		-10	–	+70	°C
Storage Temperature		-30	–	+70	°C
Soldering Conditions					
Wave Solder	Preheat: 100°C max for 2 min max; Solder temperature: 260°C ± 5°C for 5 sec max.; No clean foam flux recommended				
Manual Solder	350°C ± 5°C for 3 sec max.; Sn95Ag5 no clean solder				
Wash	Not recommended				
Moisture Sensitivity Level	1				
ESD Classification (HBM)	Not applicable				

All testing is performed at room ambient conditions except as noted. Users should verify device actual performance in their specific applications
This product is compliant to RoHS3 Directive 2015/863 Amendments of Annex II on 31 March 2015, and REACH SVHC Directive EC 1907/2006 Amendments of Annex XIV & Annex XVII on 15 January 2018.

Custom and value-added options available on request. Please contact your sales representative for additional information.

Mechanical Specifications

Series 11VR Horizontal/Side Mount Bushingless (Single)

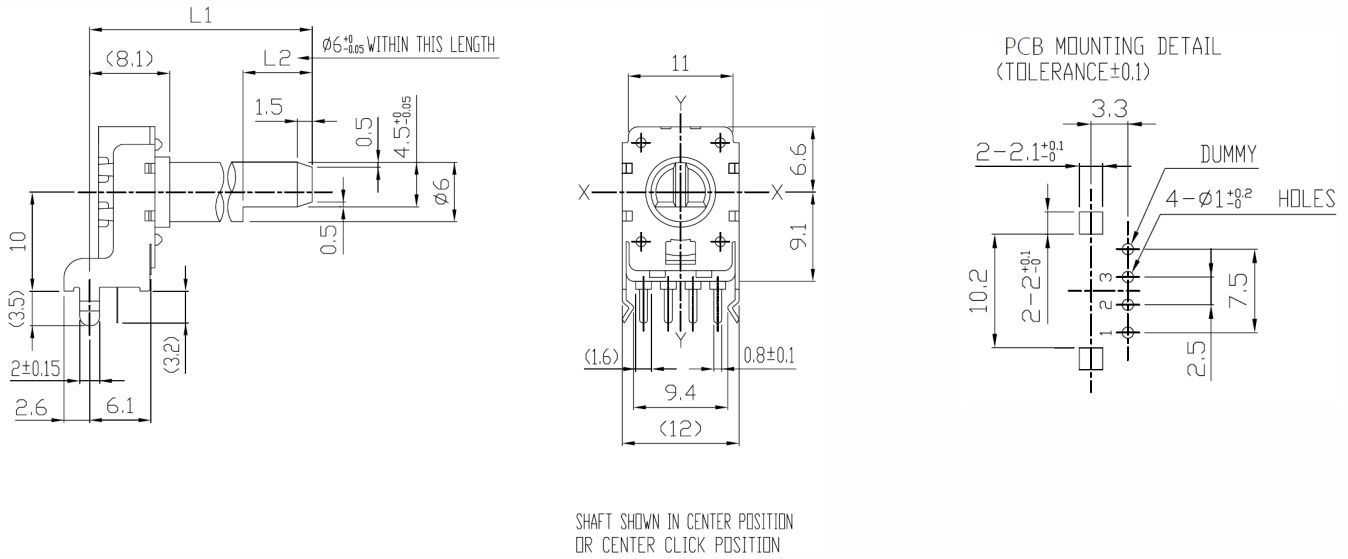

Series 11VR Vertical/Rear Mount Bushingless (Single)

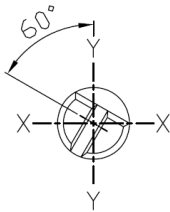
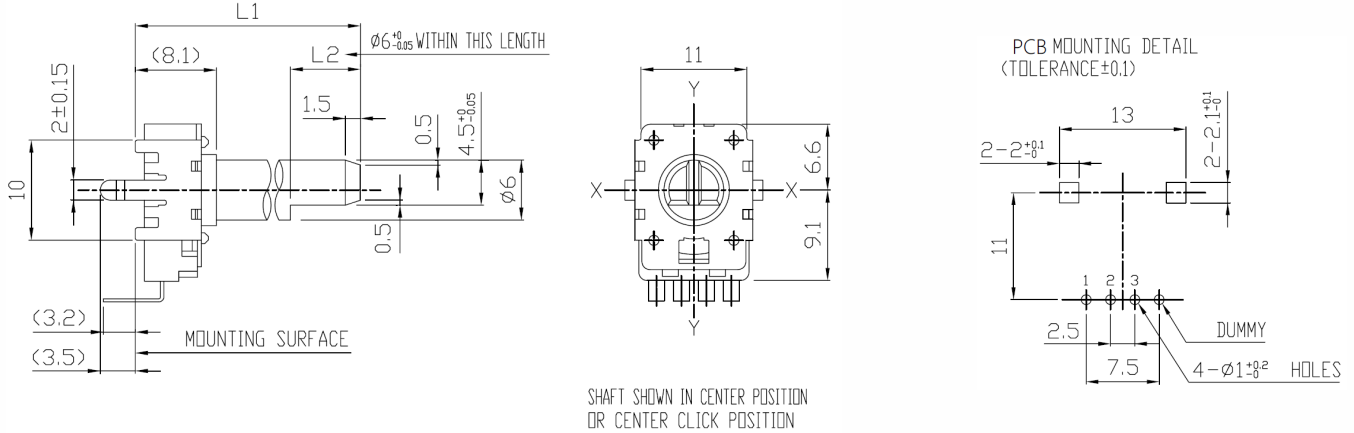

SHAFT SHOWN IN FULL CCW POSITION

CIRCUIT DIAGRAM

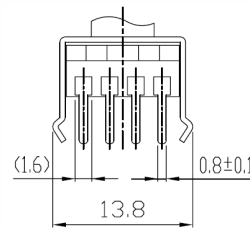
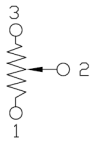

LENGTH	
L1	L2
20	7
22.5	7
25	12
27.5	12
30	12

Unit: mm

TOLERANCES UNLESS OTHERWISE SPEC	
$L \leq 10$	± 0.3
$10 < L \leq 100$	± 0.5
$100 < L$	± 0.8
ANGULAR DIMENSION	$\pm 5^\circ$

Mechanical Specifications

Series 11VR Horizontal/Side Mount with Threaded Bushing (Single)

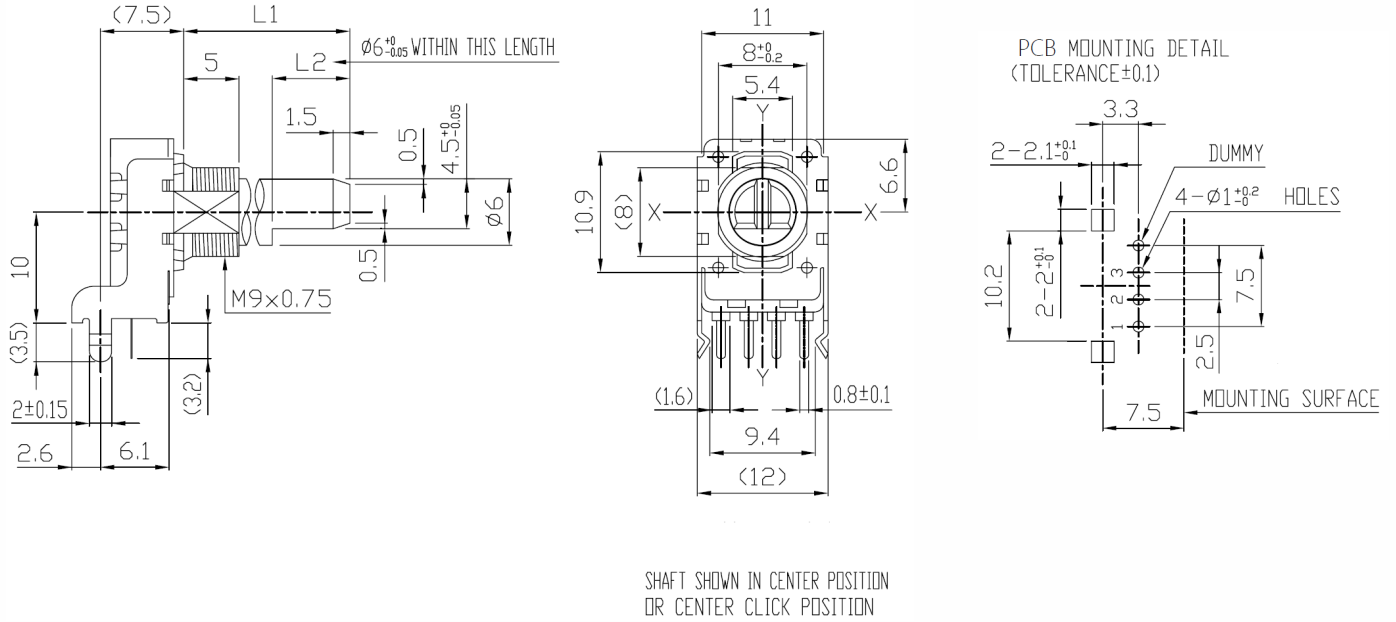

Series 11VR Vertical/Rear Mount with Threaded Bushing (Single)

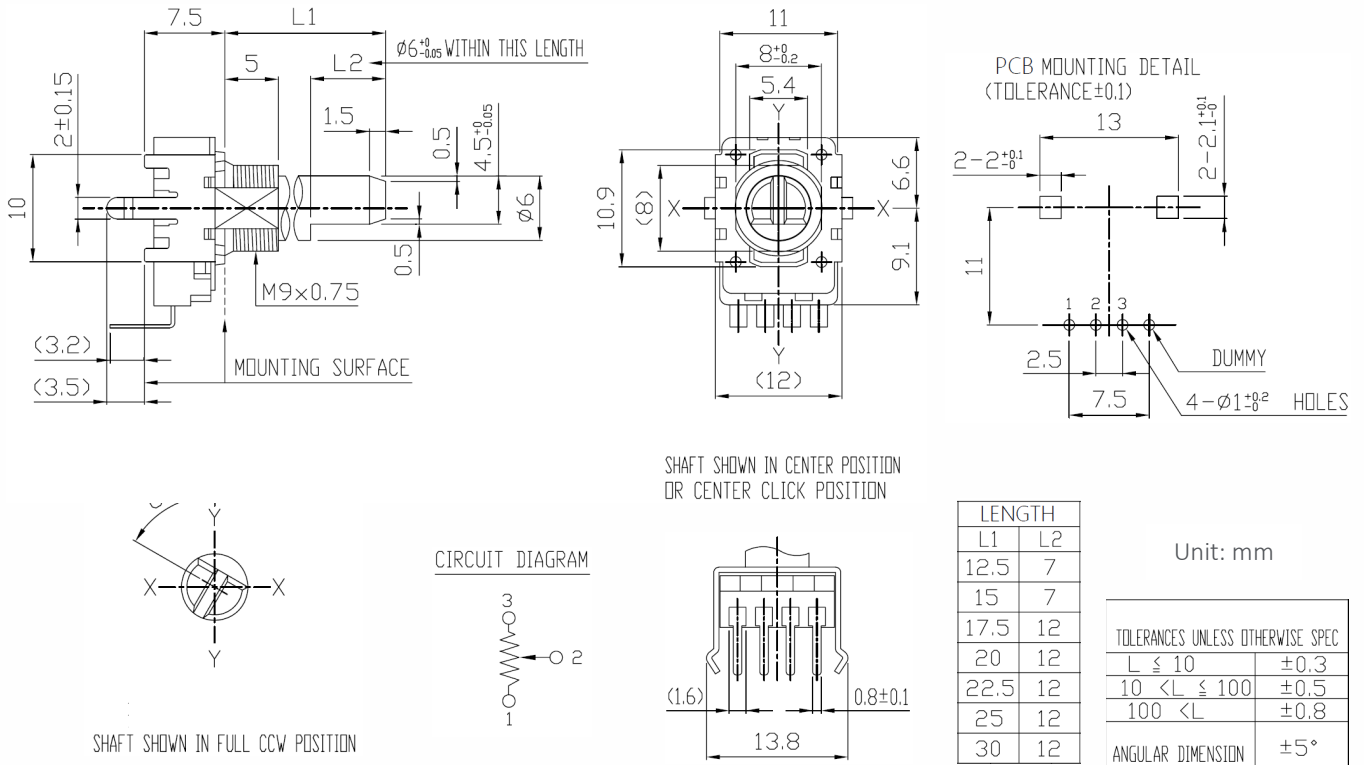

Mechanical Specifications

Series 11VR Vertical/Rear Mount Sleeve Bushing (Single)

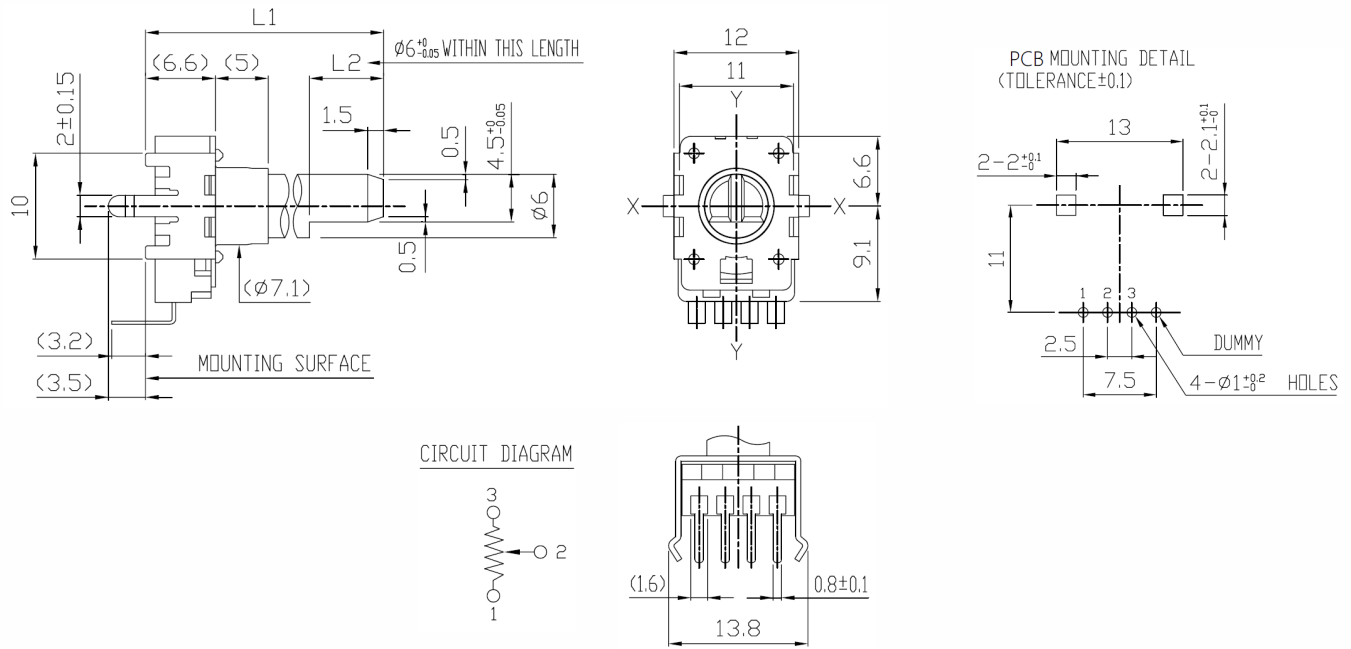

Series 11VR Vertical/Rear Mount Sleeve Bushing (Dual)

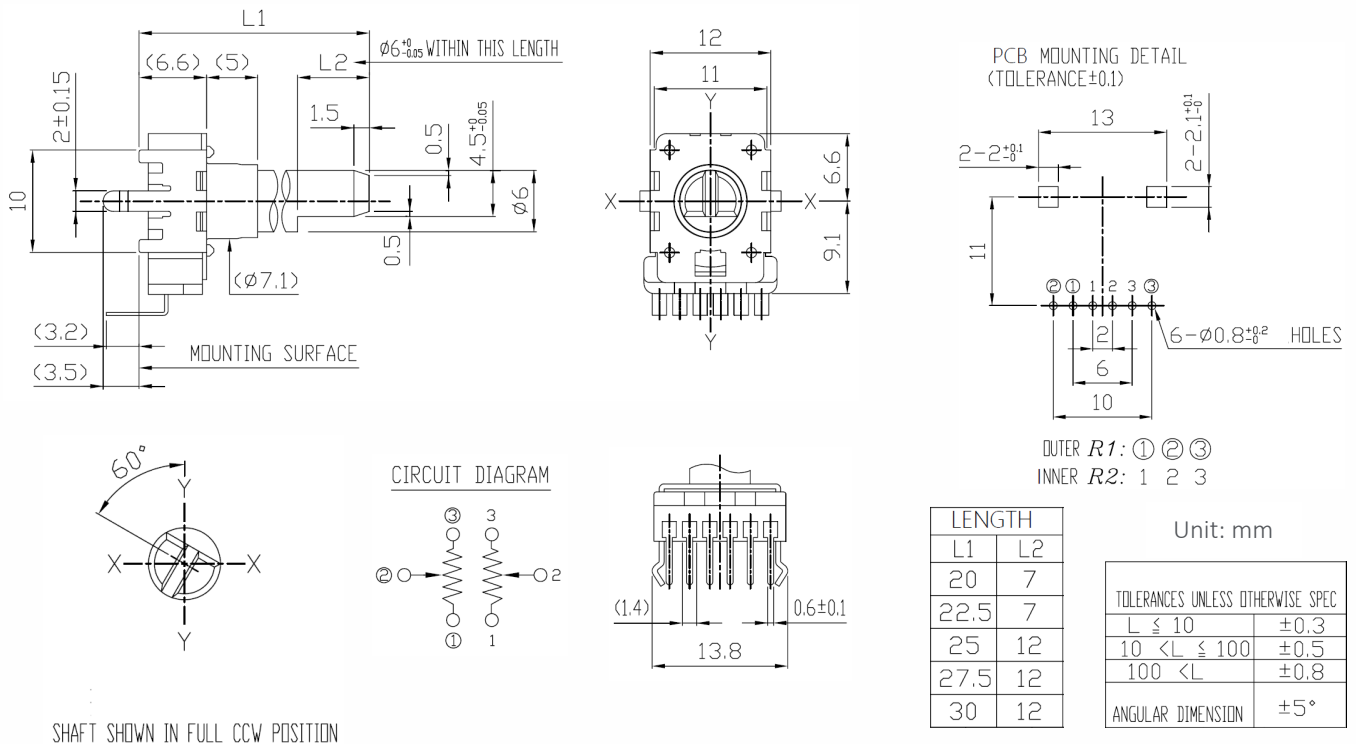

LENGTH	
L1	L2
20	7
22.5	7
25	12
27.5	12
30	12

Unit: mm

TOLERANCES UNLESS OTHERWISE SPEC	
L ≤ 10	±0.3
10 < L ≤ 100	±0.5
100 < L	±0.8
ANGULAR DIMENSION	±5°

Mechanical Specifications

Series 11VR Horizontal/Side Mount Bushingless (Dual)

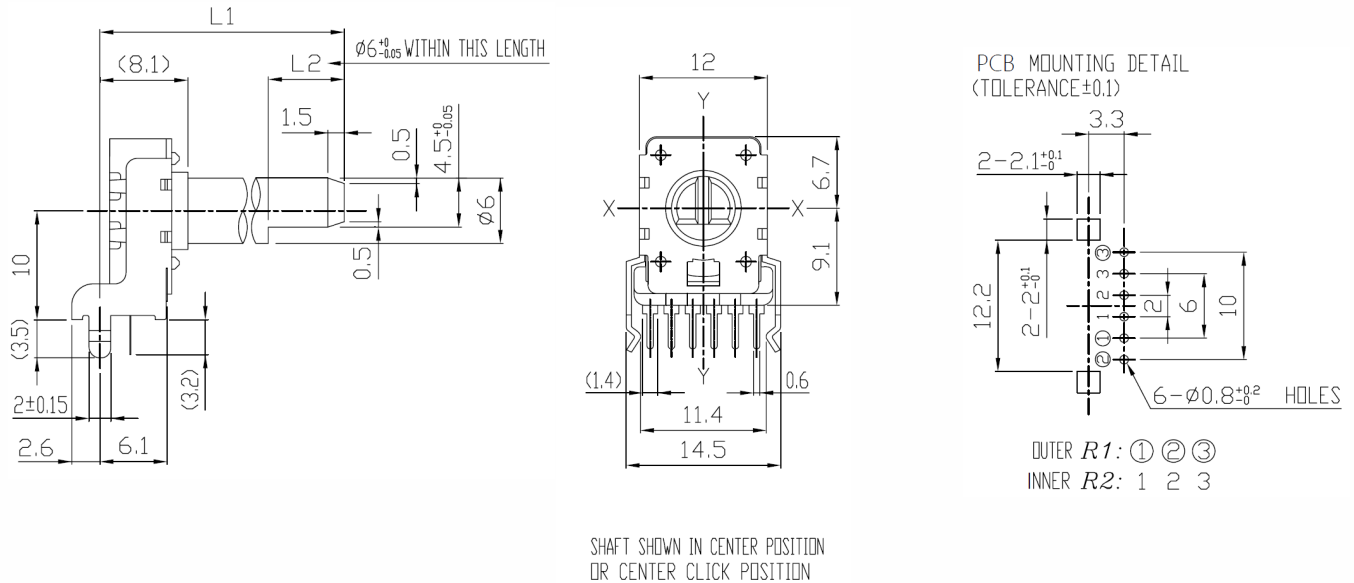

Series 11VR Vertical/Rear Mount Bushingless (Dual)

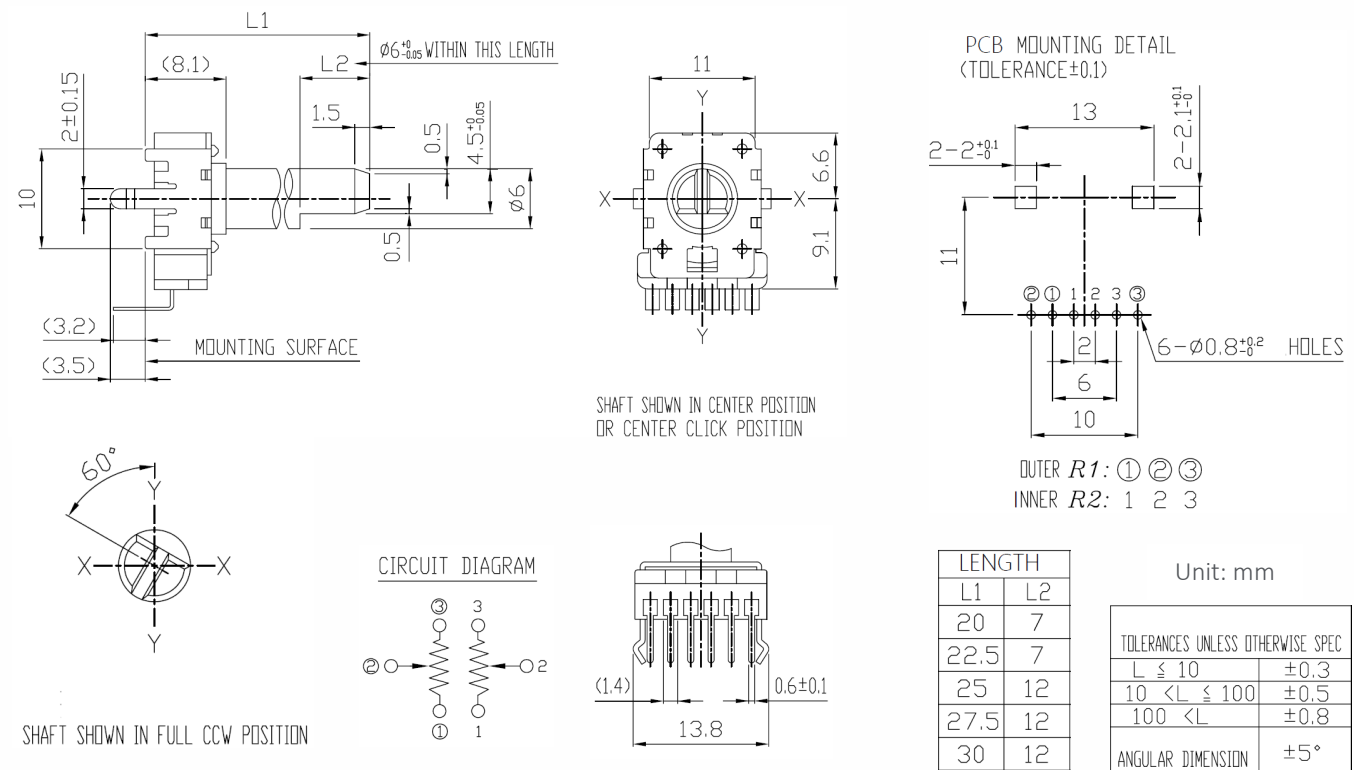

Mechanical Specifications

Series 11VR Horizontal/Side Mount with Threaded Bushing (Dual)

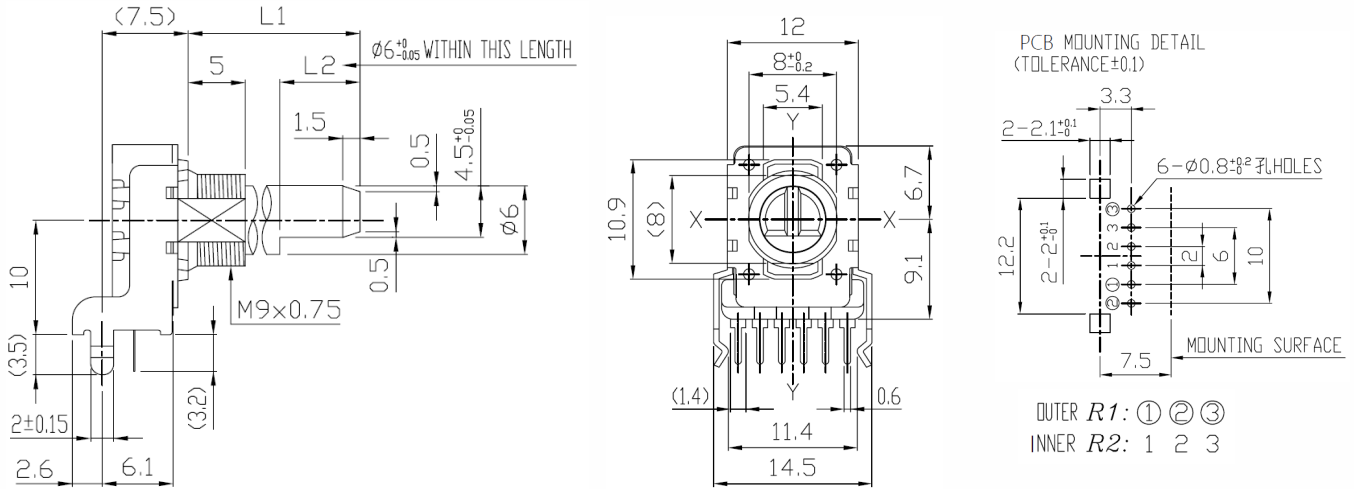

Series 11VR Vertical/Rear Mount with Threaded Bushing (Dual)

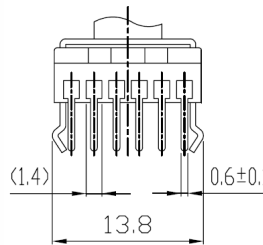
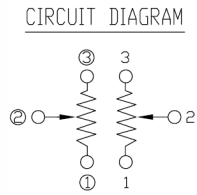
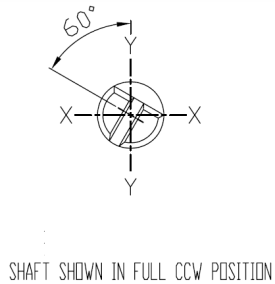
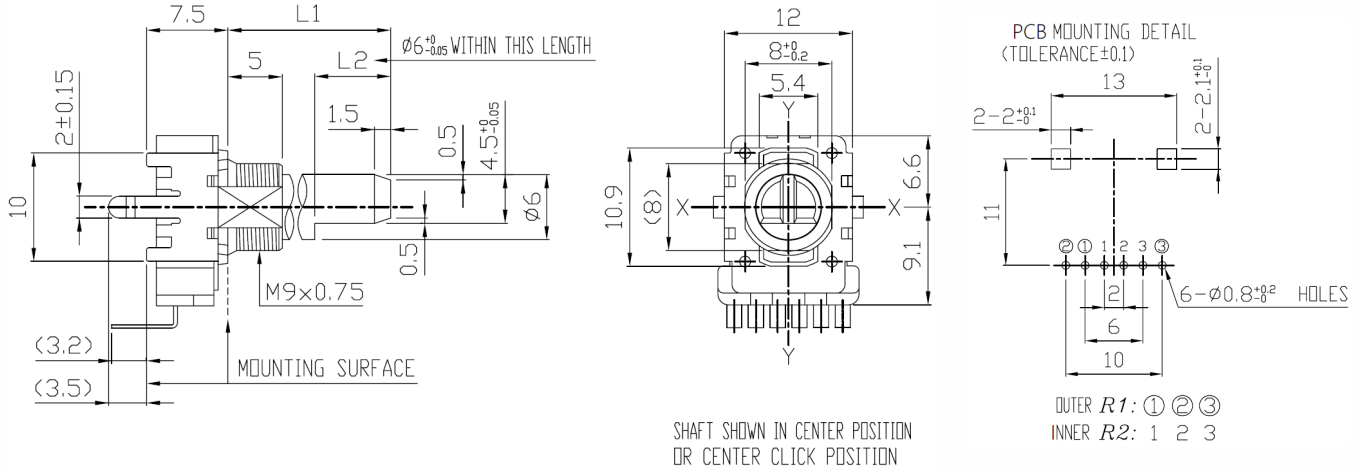

LENGTH	
L1	L2
12.5	7
15	7
17.5	12
20	12
22.5	12
25	12
30	12

Unit: mm

TOLERANCES UNLESS OTHERWISE SPEC	
$L \leq 10$	±0.3
$10 < L \leq 100$	±0.5
$100 < L$	±0.8
ANGULAR DIMENSION	±5°