

SYMBOL DEFINITION	
A DIMENSION WITHOUT AN INSPECTION REPORT SYMBOL  DOES NOT REQUIRE INSPECTION. IT MAY BE CONTROLLED ON THE INDIVIDUAL COMPONENT DRAWING.	TOTAL NO OF INSPECTIONS REQUIRED
	9
	LAST NO. USED
	8

MISSING SYMBOLS	DWG STATUS					ZONE	REVISION HISTORY	AUTH	DR	APVD1	APVD2
	DATE	STG	REV	N/P	CHG						
NO MISSING SYMBOL NUMBER	15AU05	R	02	-	-		REDRAWN TO PART DRAWING AND MAT'L SPEC WAS R0064366	270970	AMG	AMG	WTM

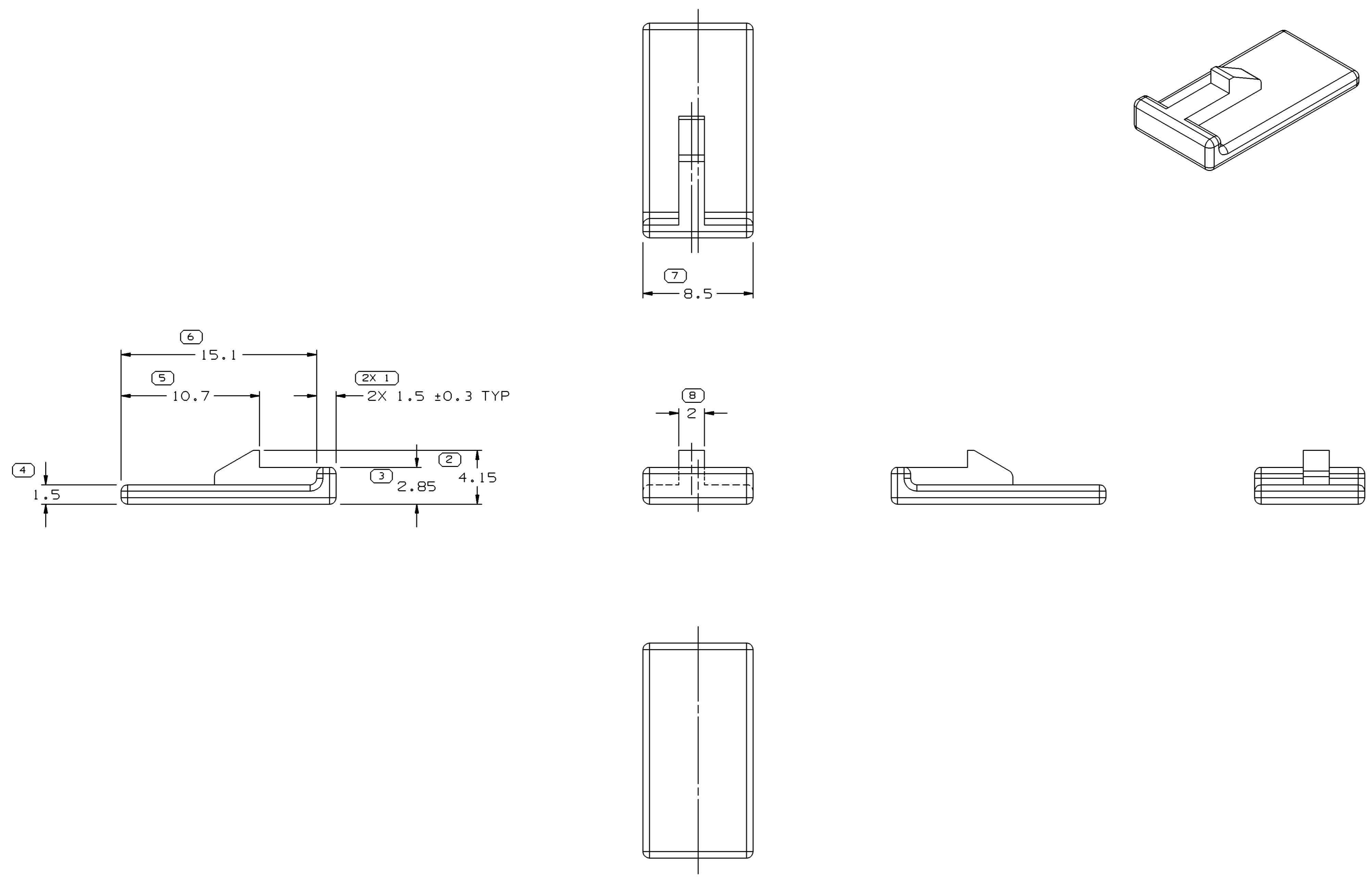

- NOTES
- UNLESS OTHERWISE SPECIFIED AND/OR INDICATED:
DIMENSIONS ARE TO FACE OF VIEW SHOWN AND AUTOMATICALLY ROUNDED BY COMPUTER FOR INSPECTION (SEE MATH MODEL FOR PRECISE DIMENSIONS). FOR ALL OTHER DIMENSIONS NOT SHOWN BUT REQUIRED FOR TOOL BUILD, SEE MATH MODEL FOR PRECISE TOOL PATH DATA.
 - MATERIAL RECYCLING CODE PER ISO 11469. (2.3)X(0.1) RAISED CHARACTERS AS SHOWN TO BE LOCATED ON ANY EXTERIOR SURFACE. OPTIONAL CONSTRUCTION TO BE NO MATERIAL RECYCLING CODE.
 - THIS PART IS NOT CONTROLLED FOR AUTOMATIC FEEDING.
 - REFERENCE MATING COMPONENTS OR EQUIVALENT:
CONNECTOR 12041433
 - (2.3)X(0.1) RAISED DELPHI CORPORATE BRAND TO BE LOCATED ON ANY EXTERIOR SURFACE, PREFERABLY VISIBLE AT FINAL ASSEMBLY. OPTIONAL CONSTRUCTION TO BE "PED" OR NO LOGO.

DIMENSIONAL RANGE (MM)		CHART E1	
FROM	TO	TOLERANCE	ANGULAR TOLERANCE
> 0	> 20	±0.15	±2°
> 20	> 30	±0.2	±2°
> 30	> 70	±0.3	±2°
> 70	> 100	±0.4	±2°
> 100	> 150	±0.5	±2°
> 150	> 200	±0.6	±2°
> 200	> 250	±0.8	±2°
> 250	> 300	±1	±2°
> 300	> 400	±1.2	±2°

DWG TYPE PART DRAWING	
STYLE	
VOLUME (CM³) 0.248	DISTR CODE D
UNLESS OTHERWISE SPECIFIED THIS DOCUMENT IS IN ACCORDANCE WITH ASME Y14.5M-1994 AS AMENDED BY THE GM GLOBAL DIMENSIONING AND TOLERANCING ADDENDUM-2001. SEPARATE PATTERNS OF FEATURES MAY BE GAGED SEPARATELY REGARDLESS OF DATUM REFERENCES.	
ALL DIMENSIONS ARE IN MILLIMETERS	
THIRD ANGLE PROJECTION	
DO NOT SCALE	
USE MATH DATA	

DELPHI
DELPHI PACKARD ELECTRIC SYSTEMS
WARREN, OH

DR	DATE
APVD1 ANDRES MENDEZ	15AU05
APVD2 ANDRES MENDEZ	15AU05
APVD3 WILLIAM T. MADDEN	19AU05
APVD4	
APVD5	

SUBSTANCES OF CONCERN AND RECYCLED CONTENT PER DELPHI 10949001

MATERIAL
M3592025 PA66 HS IM GRA MD

DRAWING NAME
LOCK TPA M/P 280 GRA MD

DRAWING NUMBER
12041434

SIZE A1	SCALE 5:1	FRAME NO 1 OF 1	SHEET NO 1 OF 1	STG R	REV 02	N/P -
------------	--------------	--------------------	--------------------	----------	-----------	----------