

SYMBOL DEFINITION		TOTAL NO OF INSPECTIONS REQUIRED	MISSING SYMBOLS
A DIMENSION WITHOUT AN INSPECTION REPORT SYMBOL DOES NOT REQUIRE INSPECTION. IT MAY BE CONTROLLED ON THE INDIVIDUAL COMPONENT DRAWING.		18	NO MISSING SYMBOL NUMBER
LAST NO. USED		18	

DATE	STG	REV	N/P	CHG	ZONE	REVISION HISTORY	AUTH	DR	AP/VD
19FE04	R	01	-	-	-	CREATED PD	249201	MJM	MJM
140C04	R	02	-	-	-	ALL PARTS - 10.7 +0/-0.1 WAS 11.55 +0/-0.1; REVISED LOCK FEATURE	260056	ADK	ADK
03MR05	R	03	-	-	-	ALL PARTS - REVISED CONN LOCKARM, UPDATED ASSEMBLY & REVISED NOTES 2 PLCS	262900	RJD	RJD
06JN05	R	04	-	-	-	ALL PARTS - UPDATED CONNECTOR	268869	CCV	JAA
030C05	R	05	-	-	-	ALL PARTS - REVISED GRAPHICS	272548	JS	JS
15N006	R	06	-	-	-	ALL PARTS - ADDED NOTE #10; REVISED NOTE #4, CHART AND TITLE BLOCK	285734	JS	JS

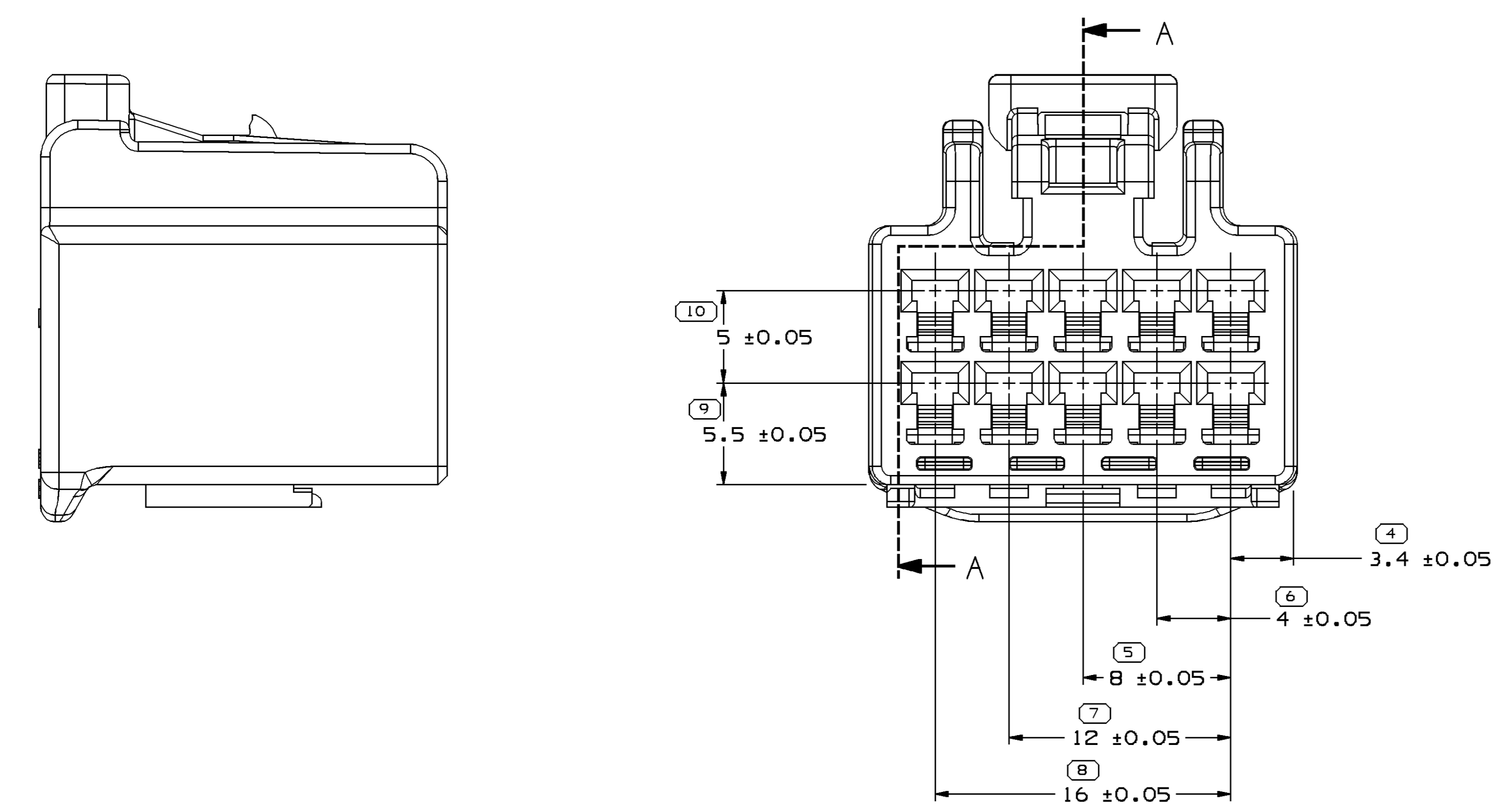

- NOTES
- UNLESS OTHERWISE SPECIFIED AND/OR INDICATED: DIMENSIONS ARE TO FACE OF VIEW SHOWN AND AUTOMATICALLY ROUNDED BY COMPUTER FOR INSPECTION (SEE MATH MODEL FOR PRECISE DIMENSIONS). FOR ALL OTHER DIMENSIONS NOT SHOWN BUT REQUIRED FOR TOOL BUILD, SEE MATH MODEL FOR PRECISE TOOL PATH DATA.
 - NO DRAFT ON TERMINAL CAVITIES UNLESS OTHERWISE SPECIFIED.
 - REFERENCE MATING COMPONENTS OR EQUIVALENT: CONNECTOR 90080-98202 (15369220 PED P/N)
 - THIS PART ACCEPTS THE FOLLOWING COMPONENTS OR EQUIVALENT: CAVITIES TO ACCEPT 2.3 II TERMINAL
 - PART SHOULD CONFORM TO TSC 1000G/TSC 1225G.
 - PACKARD HANDLING MANUAL AVAILABLE.
 - PARTS ARE AVAILABLE IN LOOSE PIECES ONLY.
 - PART CONFORMS TO TSZ6005G.
 - PART CONFORMS TO SUB PARAGRAPH "SUBSTANCE PROHIBITION AND RESTRICTION" PER TSZ0001G.
 - PERFORMANCE OF THIS PART CONFORMS TO TSC1225G REV. 3 (FEB. 2006) WHEN TESTED TO TSC1000G REV. 8 (APR. 2006) AT TEMPERATURE CLASS D, VIBRATION CLASS III.

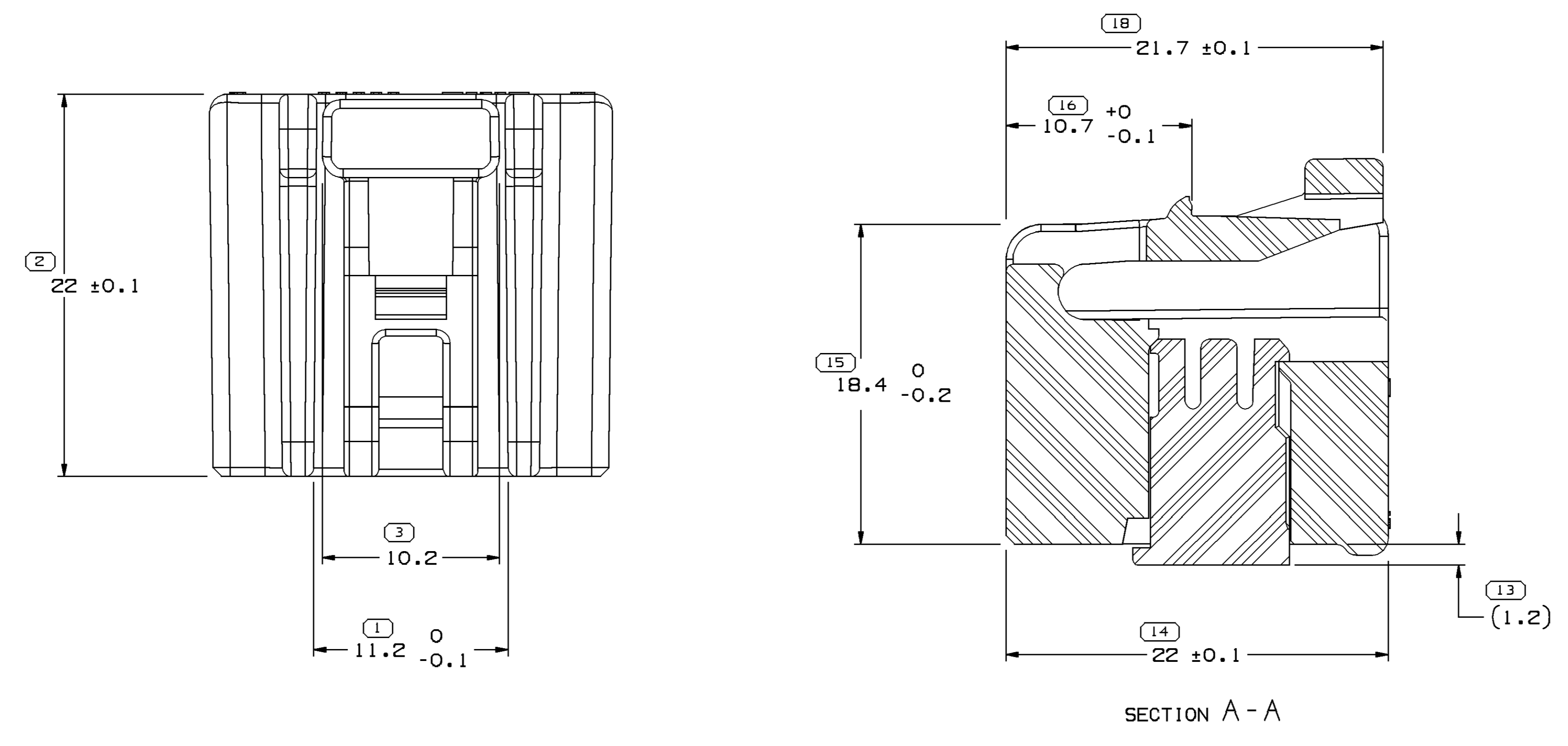
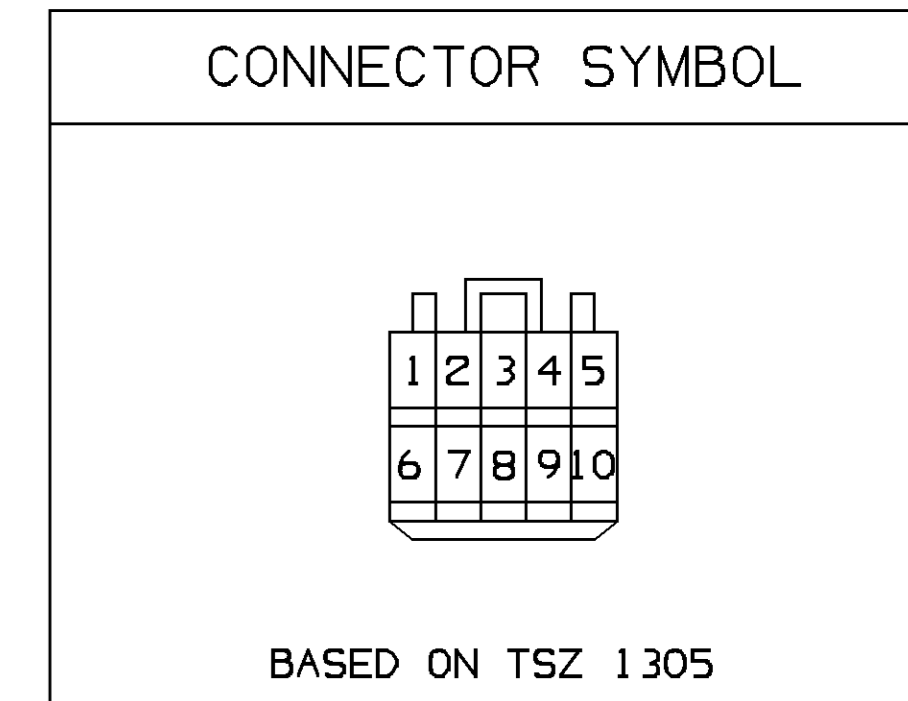
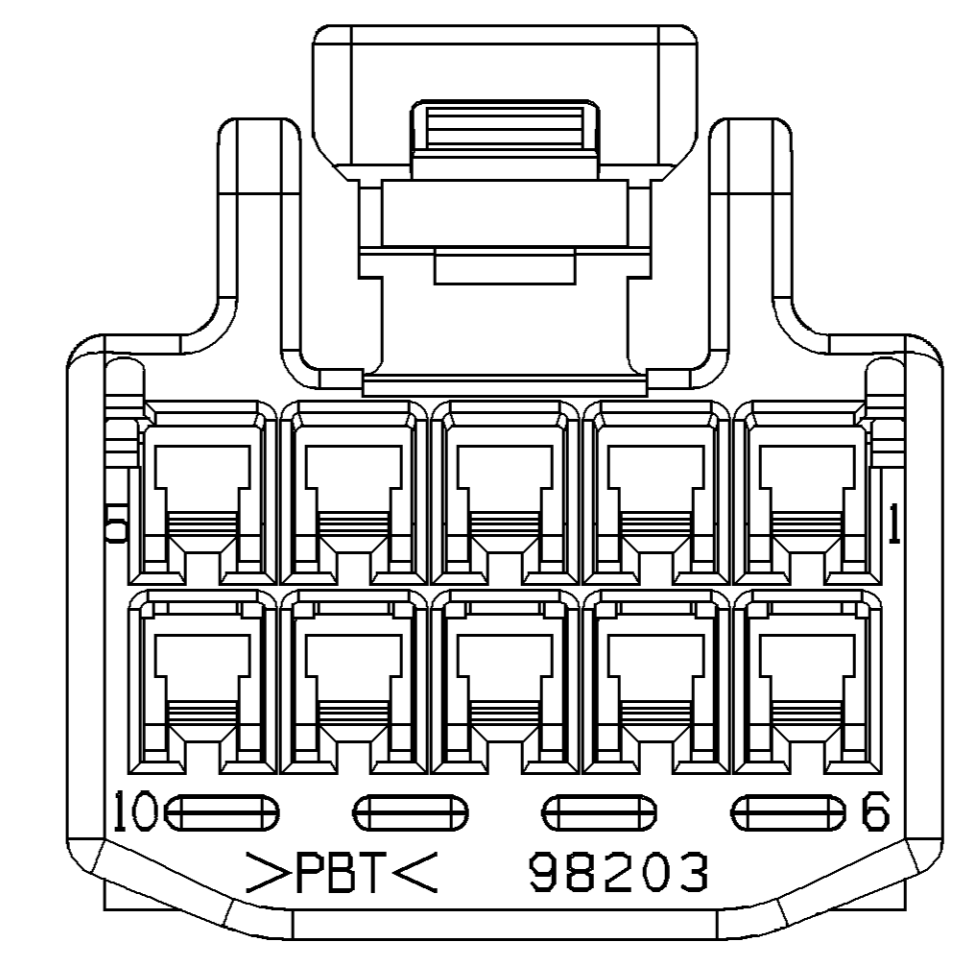

ECT No.	REVISION RECORD	WEIGHT	WEIGHT TOL.
		5.800	±0.3

TOYOTA PART NAME	TOYOTA PART No.
HOUSING, CONNECTOR FEMALE	90080-98203-A

TOYOTA MOTOR CORPORATION	
DELPHI	
DELPHI PACKARD ELECTRIC SYSTEMS WARREN, MI	
DR	DATE
APV01 M. MAYER	19FE04
APV02 M. MAYER	19FE04
APV03 T. VOLPONE	19FE04
APV04	
APV05	
SUBSTANCES OF CONCERN AND RECYCLED CONTENT PER DELPHI 1094001	
DRAWING NAME	
TAXI ASM CONN F 2.3 II	
DRAWING NUMBER	
15489183	
SIZE	SCALE
A0	5:1
FRM NO	SHEET NO
1 OF 1	1 OF 1
REV	N/P
06	-

PART NAME	ASM PART NO	REV	PED PART NO	MATERIAL SPECIFICATION AND COLOR	FINISH	JIS WIRE SIZE (MM²)	SAE WIRE SIZE NO.	TMC P/N	TMC PURCHASED P/N
TERM F 2.3 II	-	-	15305113	T0.25 TSG7100G-C2600R	GOLD PLATED	0.5-1.25	16,18,20	-	90980-0947B
	-	-	PG002264	T0.25 TSG7100G-C2600R	GOLD PLATED	0.3-0.5	20,22	-	90980-09477
	-	-	15305111	T0.25 KLF-5 EQUJIV.	PRE-TINNED	2	14	90080-98166	90980-092266
	-	-	12161199	T0.25 ASTM26000 CDA-260	PRE-TINNED	0.5-1.25	16,18,20	90080-98004	90980-092265
TSL 2.3 II 10F	-	-	12161198	T0.25 ASTM26000 CDA-260	PRE-TINNED	0.3-0.5	20,22	90080-98043	90980-092264
	-	-	15318020	M4695001 PBT NAT	-	-	-	-	-
CONN 10F 2.3 II	15485583	06	15485582	M4695008 PBT BLU	-	-	-	90080-98203-A	90980-11537L
	15485581	06	15485580	M4695003 PBT GRA	-	-	-	90080-98203-A	90980-11537GR
	15485579	06	15485578	M4695001 PBT NAT	-	-	-	90080-98203-A	90980-11537N

(12) PROCESS SENSITIVE DIMENSION	
DIMENSIONS ENCLOSED IN () INDICATE REFERENCE DIMENSIONS AND NO TOLERANCE LIMITS ARE ESTABLISHED	
DIMENSIONAL RANGE: DIM	CHART F
FROM 0 TO 10	> 10
TOLERANCE UNLESS OTHERWISE SPECIFIED	±0.15
ANGULAR TOLERANCE ±1°	

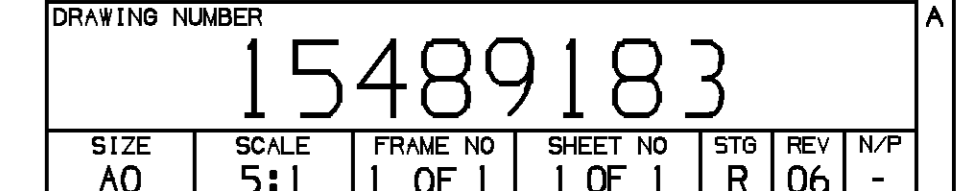
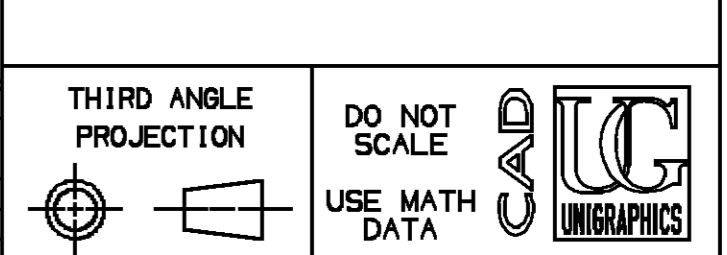

Date: 02-Dec-08 Time: 07:38