



# Type SMP Connectors

Product Catalog



Cinch Connectivity Solutions  
299 Johnson Avenue SW, Suite 100  
Waseca, MN 56093 USA

+1 507.833.8822  
[cinchconnectivity.com](http://cinchconnectivity.com)

# TABLE OF CONTENTS

Introduction	1-2
Specifications	3-8
Mounting Holes	7
Applications	9-12
Assembly Tools	13
Assembly Instructions	14-18
Competitor Cross Reference	19

# INTRODUCTION

## SMP Blind-Mate Connectors

**Johnson®** line of **SMP Blind-Mate Connectors** offers our customers a Micro-Miniature, Slide-On/Snap-On Interconnect System that aid's in the design of high-density packaging as well as axial and radial misalignment issues.

The **SMP** Interface offers superior performance up to 40 GHz and is compatible with all SMP and **GPO®** Connectors. They offer high electrical reliability where extreme shock and vibration condition's are experienced.

## Applications (Military and Commercial)

- Phased Arrays
- Active Antennas
- Satellites
- Communication
- Airborne Radar
- Shipborne Radar Equipment
- Ground Radar
- Hi-Density Modular Packaging
- Axial/Radial Misalignment Solutions

## Markets

- Aerospace
- Broadband
- Instrumentation
- Telecom
- Defense
- Microwave

## Transmission Options

- Box-to-Box
- Cable-to-Board
- Board-to-Board
- Cable-to-Panel-to-Board

\*GPO® is a registered trademark of Corning Gilbert.

# INTRODUCTION

## Description

One of the key benefits of the SMP connector interface is its use in high frequency blind-mate applications. The design of the SMP bullet and shroud system allows for both axial and radial misalignment. The basic system is comprised of an inner “bullet” adapter, and two outer receptacles called “shrouds”. The bullet provides a flexible link between the shroud connections.

In blind-mate applications, one shroud connector will be typically specified as a snap-on interface and the other as a slide-on. This ensures that the bullet adapter remains fixed in the same shroud connector when the connection is disengaged.

The two snap-on interfaces Full Detent (FD) and Limited Detent (LD) each have different engage and disengage coupling forces. The LD is typically selected as the snap-on interface in PCB mount or blind-mate applications, while the FD is mainly used for cabled connections where higher retention forces are required.

The two slide-on interfaces Smooth Bore (SM) and Catcher’s Mit (CM) allow for reduced connection forces as compared to the snap-on versions. The push-on interface creates a sliding connection that does not physically locate the mating reference planes, allowing for axial and radial misalignment. Both the SM and CM have the same engage/disengage forces; however the CM is typically specified as the shroud configuration in blind-mate applications as its generous lead-in chamfer helps capture and guide the bullet into place.

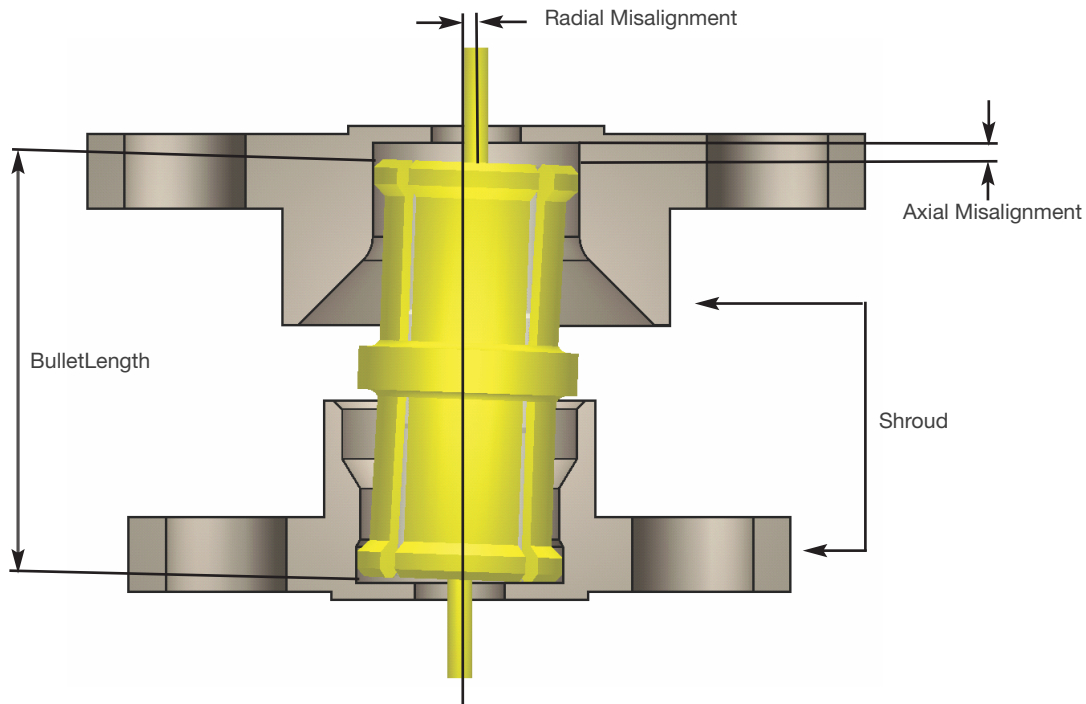

# SPECIFICATIONS

## ELECTRICAL SPECIFICATIONS

**Impedance:** 50 Ohms

**Frequency Range:**

Bullet Adapter (.254 length), Semi-Rigid Straight Cabled Connectors .....	0-40 GHz
All other In-Series Adapters, Semi-Rigid Right Angle Cabled Connectors, Field Replaceable Connectors, EndLaunch Connectors, Hermetic Feedthroughs .....	0-18 GHz
PC Mount Connectors.....	0-12 GHz

**VSWR:** (maximum)

Bullet Adapter (.254 length).....	<u>0-18 GHz</u> 1.10	<u>18-23 GHz</u> 1.15	<u>23-26.5 GHz</u> 1.30	<u>26.5-40 GHz</u> 1.70
Semi-Rigid Straight Cabled Connectors.....		<u>0-18 GHz</u> 2.0	<u>18-26.5 GHz</u> 1.35	<u>26.5-40 GHz</u> 1.70
All other In-Series Adapters .....		<u>0-4 GHz</u> 1.10	<u>4-12 GHz</u> 1.15	<u>12-18 GHz</u> 1.20
Semi-Rigid Right Angle Cabled Connectors.....				<u>0-18 GHz</u> 1.20
Field Replaceable Connectors (typical, measured back to back with seal pin.....)				<u>0-18 GHz</u>
Un-cabled Connectors (dependant on application) .....				Not Applicable 1.15

**Insertion Loss:** (dB maximum, tested at 10 GHz)

In-Series Adapters, Field Replaceable Connectors .....	0.10 √ F (GHz)
Semi-Rigid Cabled Connectors .....	0.12 √ F (GHz)
All other Un-cabled Connector .....	Not Applicable

**Working Voltage:** 335 Vrms maximum at sea level, 65 Vrms maximum at 70,000 feet

**Dielectric Withstanding:** Voltage: 500 Vrms minimum at sea level

**RF High Potential Withstanding Voltage:** 325 Vrms minimum at sea level, tested at 4 and 7 MHz

**Corona Level:** 190 Vrms minimum at 70,000 feet

**Contact Resistance:** (milliohms maximum initial, not applicable after environmental testing)

Center Contact (Connectors and Adapters).....	6.0
Outer Contact (Connectors and Adapters) .....	2.0
Cable Shield to Body (Semi-Rigid Cabled Connectors Only) .....	0.5

**Insulation Resistance:** 5000 megohms minimum

**RF Leakage:** (dB typical, tested at 2.5 GHz)

Cabled and Field Replaceable Connectors .....	-80
In-Series Adapters.....	-65
All other Un-cabled Connectors.....	Not Applicable

# SPECIFICATIONS

## MECHANICAL SPECIFICATIONS

**Interface Design:** MIL-STD-348A, Series SMP

**Engagement Force:** (pounds maximum, mated pair)

Full Detent (FD).....	15.0
Limited Detent (LD) .....	10.0
Smooth Bore and Catcher’s Mit (SM and CM).....	2.0

**Disengagement Force:** (pounds minimum, mated pair)

Full Detent (FD).....	5.0
Limited Detent (LD) .....	2.0
Smooth Bore and Catcher’s Mit (SM and CM).....	0.5

**Mated Radial Misalignment:** (inches maximum allowed, female adapters only)

Between Centerlines of Mating Planes (FD,LD, SM) .....	010
Between Centerlines of Mating Planes (CM only) .....	020

**Mated Axial Misalignment:** .010 inches maximum allowed between mating planes (female adapters only)

**Durability:** (mating cycles minimum)

Full Detent (all female connectors and adapters).....	100
Limited Detent (female adapters only) .....	500
Smooth Bore and Catcher’s Mit (female adapters only) .....	1000

**Contact Retention:** 1.5 pounds minimum axial force (captivated contacts only)

**Cable Retention:** (minimum)

	<u>Axial Force* (lbs)</u>	<u>Torque (in-oz)</u>
Cabled Connectors for RG-405 (.086 Semi-Rigid)	30	16.0
Cabled Connectors for M17/151 (.047 Semi-Rigid)	20	N/A

\*Or cable breaking strength, whichever is less



## Typical Measured Return Loss Bullet Adapter 127-0901-801

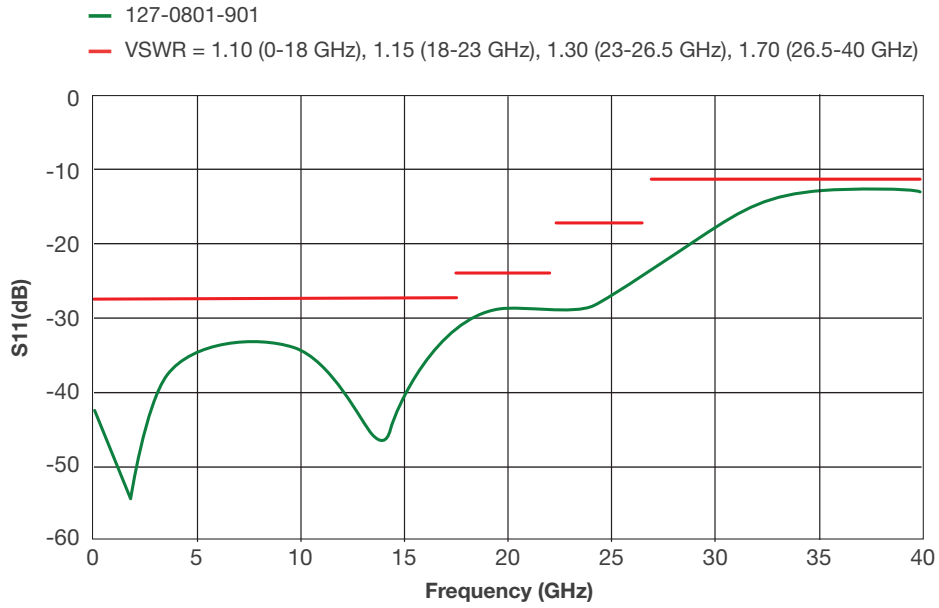

# SPECIFICATIONS

## ENVIRONMENTAL SPECIFICATIONS

(Meets or Exceeds the Applicable Paragraph of MIL-PRF-39012)

**Operating Temperature:** -65°C to +165°C

**Thermal Shock:** MIL-STD-202, Method 107, Condition B (except high temp +165°C or max high temp of cable)

**Corrosion:** MIL-STD-202, Method 101, Condition B

**Shock (specified pulse):** MIL-STD-202, Method 213, Condition I

**Vibration:** MIL-STD-202, Method 204, Condition D

**Moisture Resistance:** MIL-STD-202, Method 106 (except step 7b omitted)

## MATERIAL SPECIFICATIONS

**Spring Finger (female) and End Launch (male) Bodies:** Beryllium Copper per ASTM B196, Gold\* plated per MIL-DTL-45204 (.00005" min)

**Hermetic Seal Bodies (male):** Kovar Alloy per ASTM F15, Gold\* plated per MIL-DTL-45204 (.00005" min)

**All other Shroud Bodies (male):** Stainless Steel, Type 303, per ASTM A582, Passivated per MIL-DTL-14072 (EL 300)

**Connector and Adapter Contacts (male and female):** Beryllium Copper per ASTM B196, Gold\* plated per MIL-DTL-45204 (.00005" min)

**Hermetic Seal Center Pins:** Kovar Alloy per ASTM F15, Gold\* plated per MIL-DTL-45204 (.00005" min)

**EMI/Anti-Rock Rings:** Beryllium Copper per ASTM B196, Gold\* plated per MIL-DTL-45204 (.00003" min)

**PC Mount Legs:** Brass per ASTM B16, Gold\* plated per MIL-DTL-45204 (.00003" min)

**Connector and Adapter Insulators:** PTFE per ASTM D1710

**Hermetic Seal Glass:** Corning 7070

\*All gold plated parts include a .00005" min nickel barrier layer.

## MOUNTING HOLES

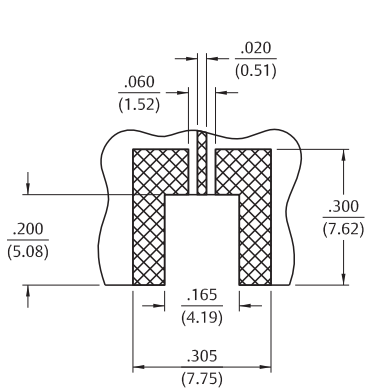

Fig 1

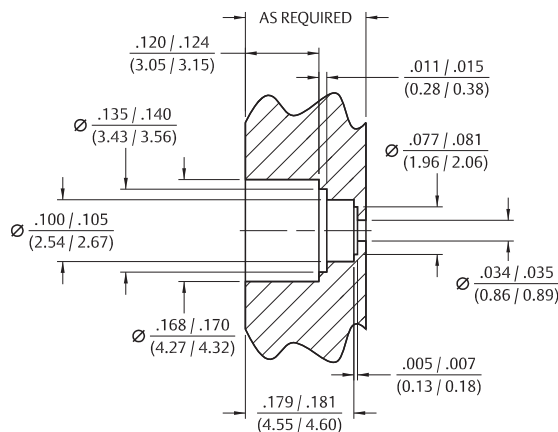

Fig 2

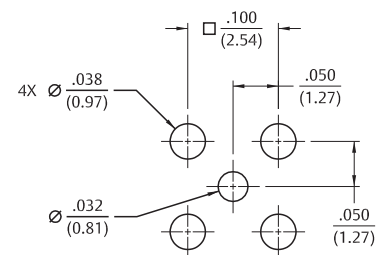
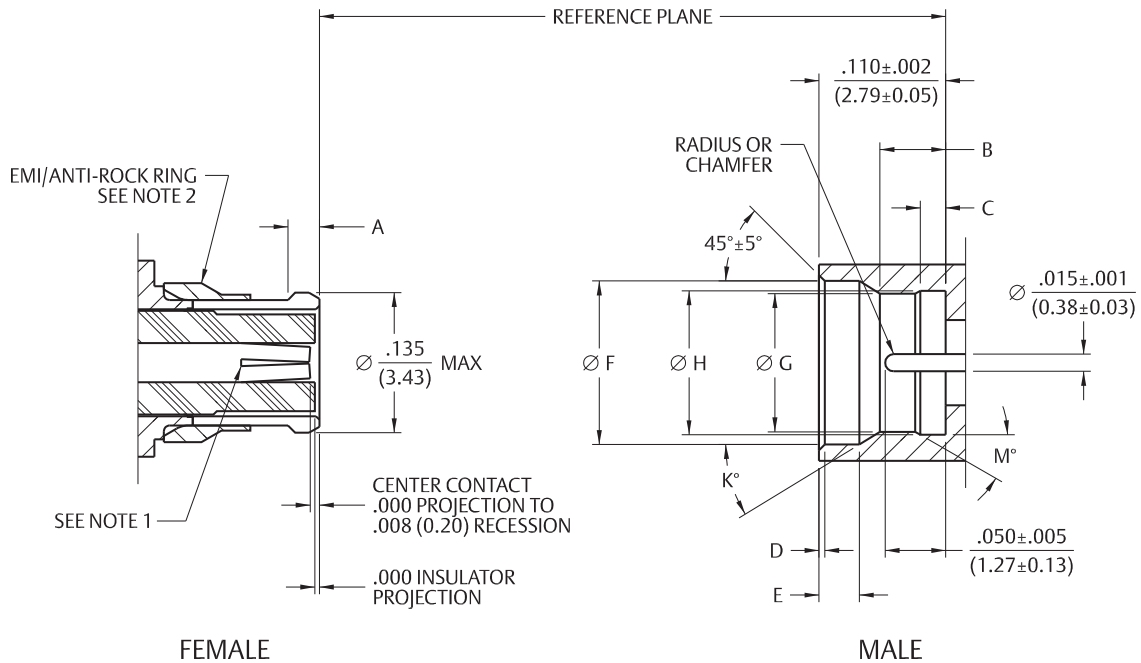

Fig 3

This pattern is for reference only. Pattern will vary depending on board type and specific electrical and mechanical requirements.

## Mating Engagement for SMP Series per MIL-STD-348A



### Notes:

1. Socket to accept mating pin  $\varnothing .015 \pm .001$  (0.38 ± 0.03).
2. EMI/Anti-Rock Ring configuration optional, used on cabled connectors only. Shall not prevent proper mating engagement.
3. All dimensions shown in inches. Metric equivalents (rounded to nearest 0.01mm) are given for general information only.

## SMP Female Connector Interface

Dimension	Cabled		Uncabled	
	Minimum	Maximum	Minimum	Maximum
A	.025 (0.64)	.035 (0.89)	.018 (0.46)	.025 (0.64)

## SMP Male Connector Interface

Dimension	Full Detent		Limited Detent		Smooth Bore		Catcher's Mit	
	Minimum	Maximum	Minimum	Maximum	Minimum	Maximum	Minimum	Maximum
B	.051 (1.30)	.057 (1.45)	.054 (1.37)	.060 (1.52)	.059 (1.50)	.065 (1.65)	N/A	N/A
C	.0205 (0.52)	.0235 (0.60)	.0205 (0.52)	.0235 (0.60)	N/A	N/A	N/A	N/A
D	.003 (0.08)	.008 (0.20)	.003 (0.08)	.008 (0.20)	.003 (0.08)	.008 (0.20)	.043 (1.09)	.047 (1.19)
E	.033 (0.84)	.037 (0.94)	.033 (0.84)	.037 (0.94)	.033 (0.84)	.037 (0.94)	N/A	N/A
F	.139 (3.53)	.145 (3.68)	.139 (3.53)	.145 (3.68)	.139 (3.53)	.145 (3.68)	.123 (3.12)	.127 (3.23)
G	.114 (2.90)	.118 (3.00)	.118 (3.00)	.122 (3.10)	.123 (3.12)	.127 (3.23)	N/A	N/A
H	.124 (3.15)	.126 (3.20)	.124 (3.15)	.126 (3.20)	N/A	N/A	N/A	N/A
K	35° REF	35° REF	35° REF	35° REF	35° REF	35° REF	N/A	N/A
M	30° REF	30° REF	30° REF	30° REF	N/A	N/A	N/A	N/A

+1 507.833.8822

[cinchconnectivity.com](http://cinchconnectivity.com)

# APPLICATION

## Straight Solder Type Cabled Female

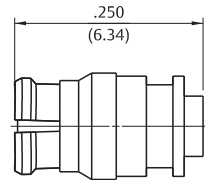

Fig 1

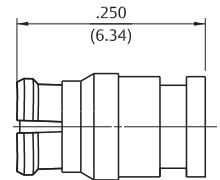
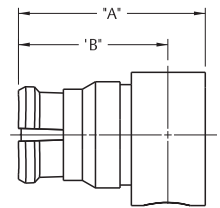
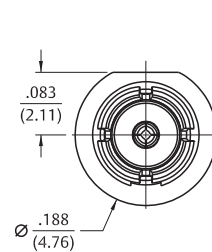
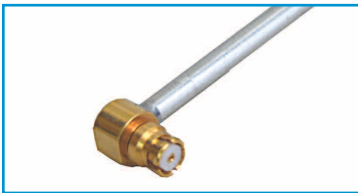

Fig 2

Cable Type	VSWR & Freq. Range*	Gold Plated	Figure
M17/151, .047 Semi-Rigid	1.20 Max 0-18 GHz, 1.35 Max 18-26.5 GHz, 1.70 Max 26.5-40 GHz	127-0692-001	1
RG-405, .086 Semi-Rigid	1.20 Max 0-18 GHz, 1.35 Max 18-26.5 GHz, 1.70 Max 26.5-40 GHz	127-0693-001	2

\* Specifications dependant on cable ratings

## Right Angle Solder Type Cabled Female



Cable Type	VSWR & Freq. Range	Gold Plated	"A"	"B"
M17/151, .047 Semi-Rigid	1.20 Max 0-18 GHz	127-0692-101	.248 (6.30)	.197 (5.00)
RG-405, .086 Semi-Rigid	1.20 Max 0-18 GHz	127-0693-101	.271 (6.88)	.209 (5.31)

## Straight PCMountMale Receptacle

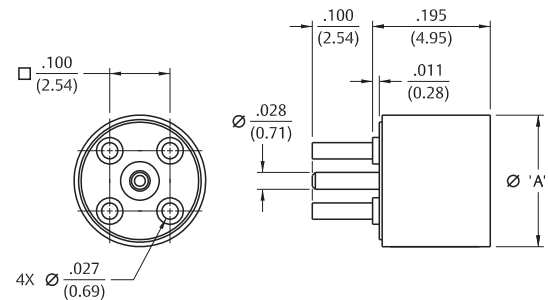

Interface	Freq. Range	Passivated*	"A"
Full Detent	0-12 GHz	127-0701-201	.218 (5.54)
Limited Detent	0-12 GHz	127-1701-201	.218 (5.54)
Smooth Bore	0-12 GHz	127-2701-201	.218 (5.54)
Catcher's Mit	0-12 GHz	127-3701-201	.234 (5.94)

\* Base and legs Gold plated brass

Mounting hole layout figure 3 on page 7.

# APPLICATION

## End Launch Male Receptacle - Surface Mount

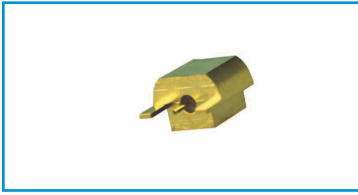

Interface	Freq. Range	Gold Plated	Figure
Full Detent	0-18 GHz	127-0701-801	Stock
Full Detent	0-18 GHz	127-0701-802	Tape and Reel -1000 pieces
Limited Detent	0-18 GHz	127-1701-801	Stock
Limited Detent	0-18 GHz	127-1701-802	Tape and Reel -1000 pieces
Smooth Bore	0-18 GHz	127-2701-801	Stock
Smooth Bore	0-18 GHz	127-2701-802	Tape and Reel -1000 pieces

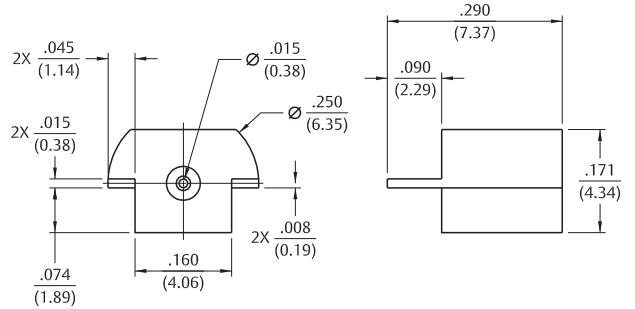

Mounting hole layout figure 1 on page 7.

## 2-Hole Flange Mount Male Shroud - Without Contact

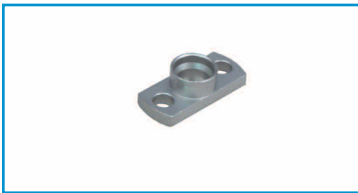

Interface	Passivated
Full Detent	127-0701-602
Limited Detent	127-1701-602
Smooth Bore	127-2701-602

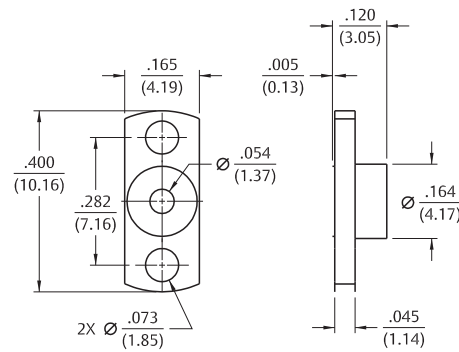

## 2-Hole Flange Mount Male Catcher's Mit Shroud - Without Contact



Interface	Passivated
Catcher's Mit	127-3701-602

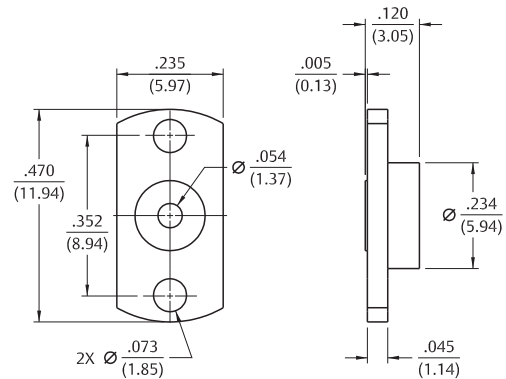

+1 507.833.8822

[cinchconnectivity.com](http://cinchconnectivity.com)

# APPLICATION

## 2-Hole Flange Mount Male Field Replaceable

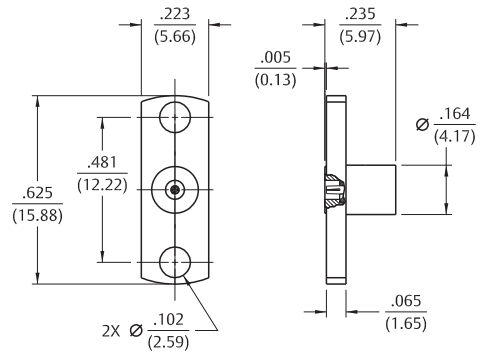
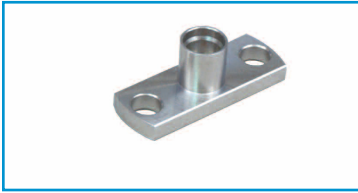

Interface	VSWR & Freq. Range*	Passivated	Accepts Pin Size
Full Detent	1.15 Typical 0-18 GHz	127-0701-612	.012 (.030)
Limited Detent	1.15 Typical 0-18 GHz	127-1701-612	.012 (.030)
Smooth Bore	1.15 Typical 0-18 GHz	127-2701-612	.012 (.030)

\* Two connectors mated back to back with hermetic seal fixture

## Hermetic Seal Male

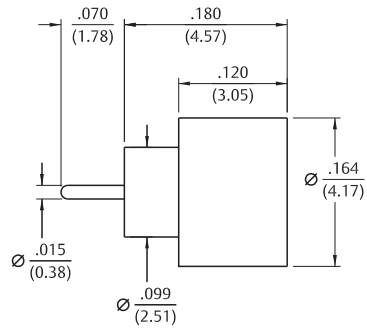
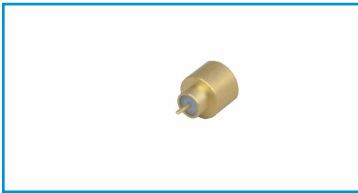

Interface	Freq. Range	Gold plated
Full Detent	0-18 GHz	127-0701-601
Limited Detent	0-18 GHz	127-1701-601
Smooth Bore	0-18 GHz	127-2701-601

Mounting hole layout figure 2 on page 7.

## Female to Female Bullet Adapter

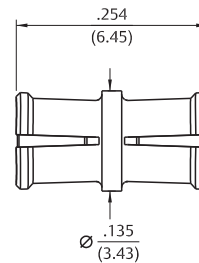

VSWR & Freq. Range	Gold plated
1.10 Max 0-18 GHz, 1.15 Max 18-23 GHz, 1.30 Max 23-26.5 GHz, 1.70 Max 26.5-40 GHz	127-0901-801



# APPLICATION

## Female to Female Adapter

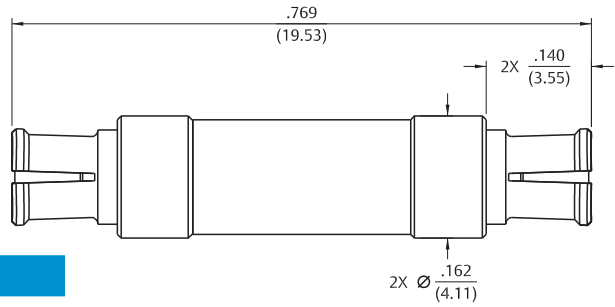

VSWR & Freq. Range	Gold plated
--------------------	-------------

1.10 Max 0-4 GHz, 1.15 Max 4-12 GHz, 1.20 Max 12-18 GHz	127-0901-811
---	--------------

## Male to Male Catcher's Mit Adapter

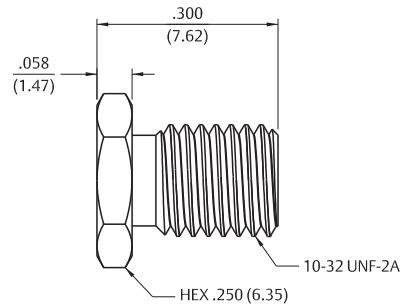

Interface	VSWR & Freq. Range	Passivated
Full Detent	1.10 Max 0-4 GHz, 1.15 Max 4-12 GHz, 1.20 Max 12-18 GHz	127-0901-821
Limited Detent	1.10 Max 0-4 GHz, 1.15 Max 4-12 GHz, 1.20 Max 12-18 GHz	127-1901-822
Smooth Bore	1.10 Max 0-4 GHz, 1.15 Max 4-12 GHz, 1.20 Max 12-18 GHz	127-2901-821

# ASSEMBLY TOOLS

## SMP Customer Tooling

Accurate assembly of the Semi-Rigid Cabled Connectors is obtained with the tools listed below. Industry standard devices are used if possible for customer convenience and tool compatibility.

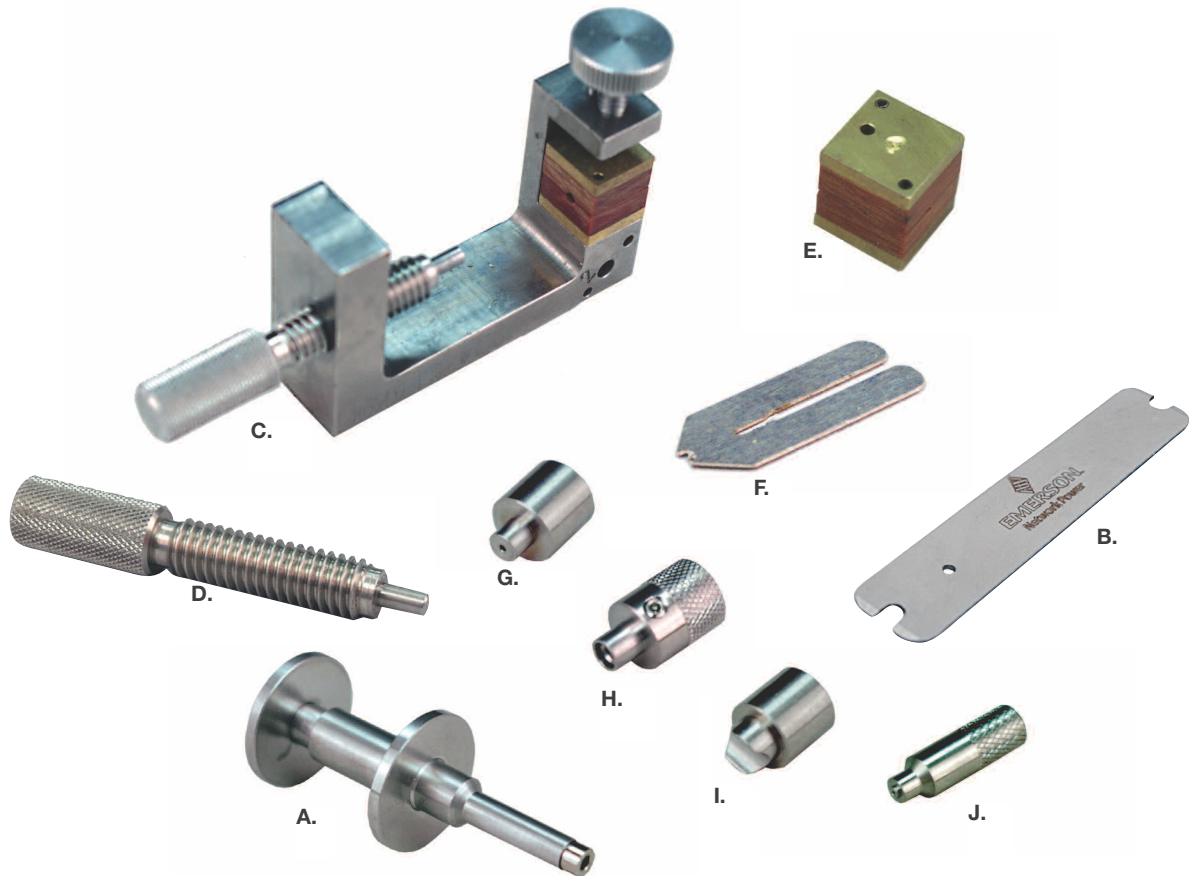

Item	Description	Park Number
A	SMP Bullet Extraction Tool	127-0000-900
B	SMP Cabled Connector Removal Tool	127-0000-901
C	Soldering Vise (does not include clamp inserts or stop screw)	140-0000-962
D	Stop Screw for Soldering Vise	140-0000-981
E	Semi-Rigid Cable Clamp Inserts for .086" OD Cable Semi-Rigid Cable Clamp Inserts for .047" OD Cable	140-0000-964 140-0000-997
F	Solder Shim for .086" OD Cable	140-0000-984
G	SMP Center Contact Holder	127-0000-902
H	SMP Interface Locator Tool	127-0000-903
I	SMP Right Angle Body Holder	127-0000-904
J	SMP FD Shroud Centering Tool SMP LD Shroud Centering Tool SMP SB Shroud Centering Tool	127-0000-905 127-0000-906 127-0000-907



# ASSEMBLY INSTRUCTIONS

## SMP Straight Female Solder Style for .047 OD Semi-Rigid Cable

1. Identify tools (5 piece parts) and connector parts (3 piece parts).
2. Strip cable jacket and dielectric to dimension shown. Do not nick center conductor. Clean all debris from prepared cable.
3. Insert center conductor into cable stop as shown and place contact onto center conductor.
4. Insert contact into contact holder fixture and clamp cable in vise. Tighten stop screw until light pressure is applied between contact, cable stop and cable jacket.
5. Solder contact to center conductor through solder hole using .016 (0.41) diameter flux core solder wire or solder paste. Use a minimum amount of solder and heat for a good joint. Do not allow heat to build up for a long period of time as cable stop may melt.
6. After solder joint has cooled, remove cable from vise. Remove any excess solder from contact with a sharp blade and clean all debris from contact and cable.
7. Insert contact into connector assembly, making sure cable stop bottoms out against internal shoulder of connector body. Insert connector assembly into interface location fixture and clamp cable in vise. Make sure connector assembly is fully engaged within location fixture. Tighten stop screw until light pressure is applied between connector assembly and cable stop.
8. Solder end of connector body to cable jacket, using a minimum amount of solder and heat for a full fillet joint. Allow assembly to cool before removing connector from vise and location fixture. Best results are obtained when contact location is flush to .004 (0.10) recessed from reference plane. Interface location fixture is pre-set at factory, but can be adjusted to control location.

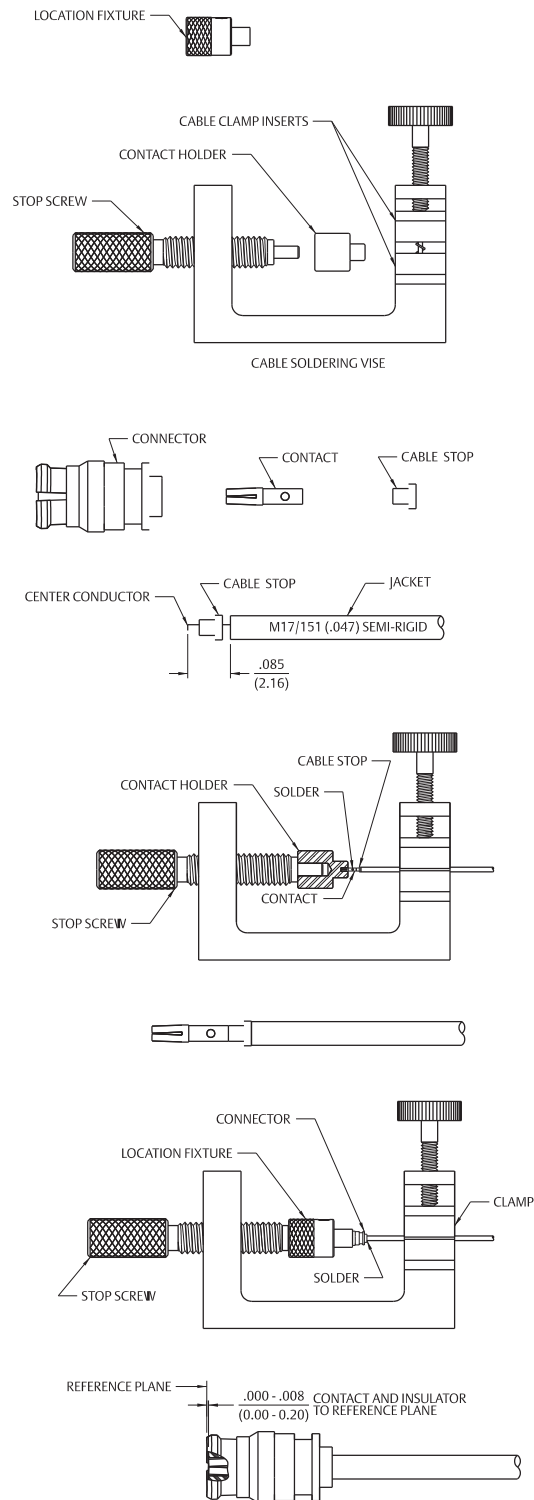

Cable Group	Part Number
MIL-C-17/151, .047 Semi-Rigid	127-0692-101

Tool	Part Number
Cable Vise	140-0000-962
Stop Screw	140-0000-981
Clamp Inserts	140-0000-997
Contact Holder	127-0000-902
Interface Location Fixture	127-0000-903

+1 507.833.8822

[cinchconnectivity.com](http://cinchconnectivity.com)

# ASSEMBLY INSTRUCTIONS

## SMP Right Angle Female Solder Style for .047 OD Semi-Rigid Cable

1. Identify tools (5 piece parts) and connector parts (3 piece parts).
2. Strip cable jacket and dielectric to dimension shown. Do not nick center conductor. Clean all debris from prepared cable.
3. Insert center conductor into cable stop as shown. Make sure slot in connector contact is aligned with cross hole in body as shown. Insert cable into cross hole in connector body, making sure cable stop bottoms out against internal shoulder of connector body.
4. Insert connector assembly into interface location fixture and clamp cable in vise using body holder fixture as shown. Tighten stop screw until light pressure is applied between connector body, cable stop and cable jacket.
5. Solder contact to center conductor through rear access port in connector body using a minimum amount of solder and heat for a good joint.
6. After center conductor solder joint has cooled, solder connector body to cable jacket, using a minimum amount of solder and heat for a full fillet joint. Take care so that solder does not flow onto anti-rock ring or into rear access port. Allow assembly to cool before removing connector from vise and location fixture.
7. Using a fixture plate as shown, press end cap into rear access port using a .156 (3.96) diameter flat punch until fully seated within body counter bore.
8. Best results are obtained when contact location is flush to .004 (0.10) recessed from reference plane. Interface location fixture is pre-set at factory, but can be adjusted to control location.

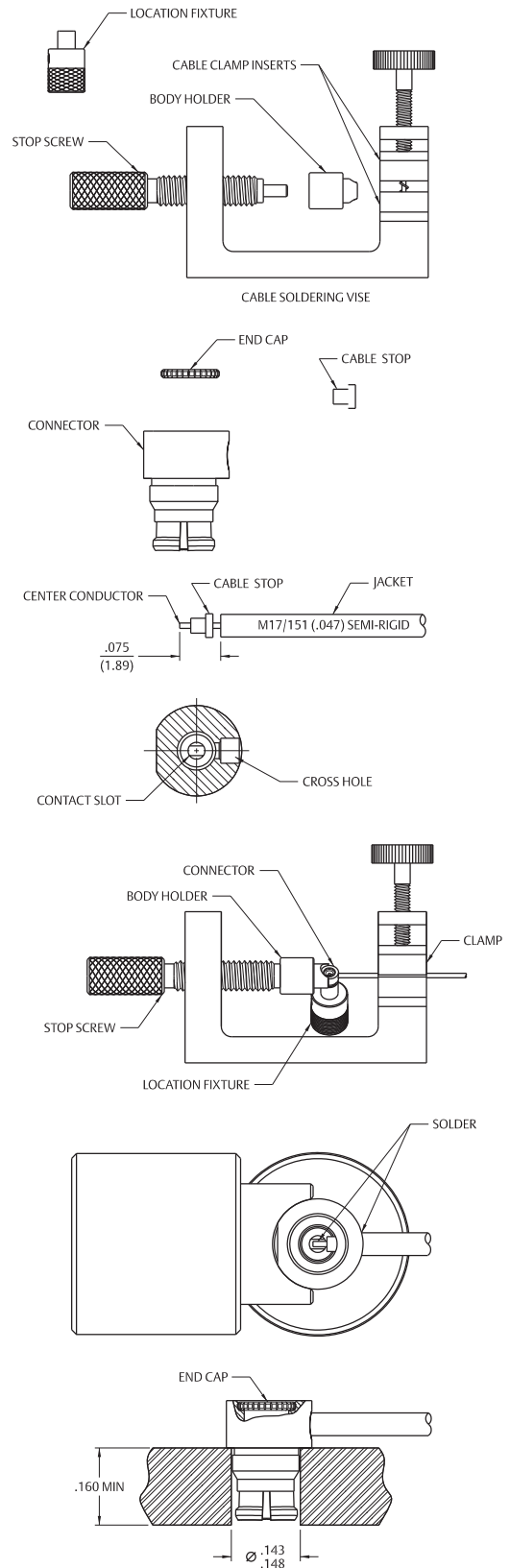

Cable Group	Part Number
MIL-C-17/151, .047 Semi-Rigid	127-0692-101

Tool	Part Number
Cable Vise	140-0000-962
Stop Screw	140-0000-981
Clamp Inserts	140-0000-997
Body Holder	127-0000-904
Interface Location Fixture	127-0000-903



# ASSEMBLY INSTRUCTIONS

## SMP Straight Female Solder Style for .086 OD Semi-Rigid Cable

1. Identify tools (6 piece parts) and connector parts (2 piece parts).
2. Strip cable jacket and dielectric to dimension shown. Do not nick center conductor. Clean all debris from prepared cable.
3. Place contact onto center conductor, insert solder shim between cable jacket and contact.
4. Insert contact into contact holder fixture and clamp cable in vise. Tighten stop screw until light pressure is applied between contact, solder shim and cable jacket.
5. Solder contact to center conductor through solder hole using .016 (0.41) diameter flux core solder wire or solder paste. Use a minimum amount of solder and heat for a good joint. Do not allow heat to build up for a long period of time as cable dielectric will expand.
6. After solder joint has cooled, remove solder shim and cable from vise. Remove any excess solder from contact with a sharp blade and clean all debris from contact and cable.
7. Insert contact into connector assembly, making sure cable jacket bottoms out against internal shoulder of connector body. Insert connector assembly into interface location fixture and clamp cable in vise. Make sure connector assembly is fully engaged within location fixture. Tighten stop screw until light pressure is applied between connector assembly and cable jacket.
8. Solder end of connector body to cable jacket, using a minimum amount of solder and heat for a full fillet joint. Allow assembly to cool before removing connector from vise and location fixture. Best results are obtained when contact location is flush to .004 (0.10) recessed from reference plane. Interface location fixture is pre-set at factory, but can be adjusted to control location.

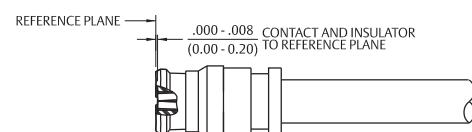
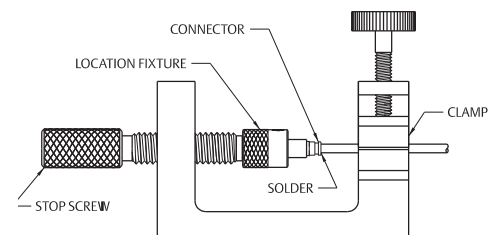
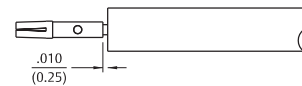
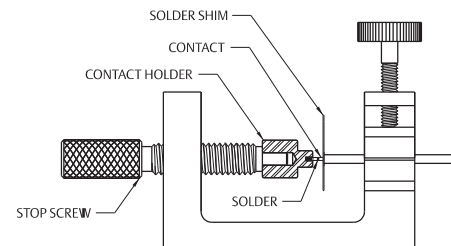
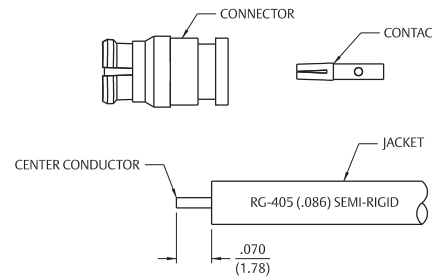
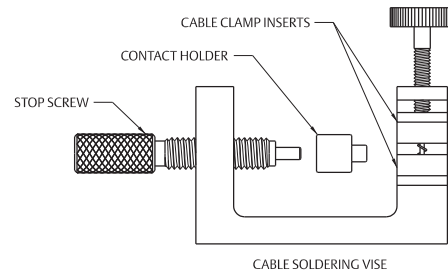

Cable Group	Part Number
RG-405, .086 Semi-Rigid	127-0693-001

Tool	Part Number
Cable Vise	140-0000-962
Stop Screw	140-0000-981
Clamp Inserts	140-0000-964
Solder Shim	140-0000-984
Contact Holder	127-0000-902
Interface Location Fixture	127-0000-903

+1 507.833.8822

[cinchconnectivity.com](http://cinchconnectivity.com)

# ASSEMBLY INSTRUCTIONS

## SMP Right Angle Female Solder Style for .086 OD Semi-Rigid Cable

1. Identify tools (5 piece parts) and connector parts (2 piece parts).
2. Strip cable jacket and dielectric to dimension shown. Do not nick center conductor. Clean all debris from prepared cable.
3. Make sure slot in connector contact is aligned with cross hole in body as shown. Insert cable into cross hole in connector body, making sure cable jacket bottoms out against internal shoulder of connector body.
4. Insert connector assembly into interface location fixture and clamp cable in vise using body holder fixture as shown. Tighten stop screw until light pressure is applied between connector body and cable jacket.
5. Solder contact to center conductor through rear access port in connector body using a minimum amount of solder and heat for a good joint. Do not allow solder to build up along exposed center conductor.
6. After center conductor solder joint has cooled, solder connector body to cable jacket, using a minimum amount of solder and heat for a full fillet joint. Take care so that solder does not flow onto anti-rock ring or into rear access port. Allow assembly to cool before removing connector from vise and location fixture.
7. Using a fixture plate as shown, press end cap into rear access port using a .156 (3.96) diameter flat punch until fully seated within body counter bore.
8. Best results are obtained when contact location is flush to .004 (0.10) recessed from reference plane. Interface location fixture is pre-set at factory, but can be adjusted to control location.

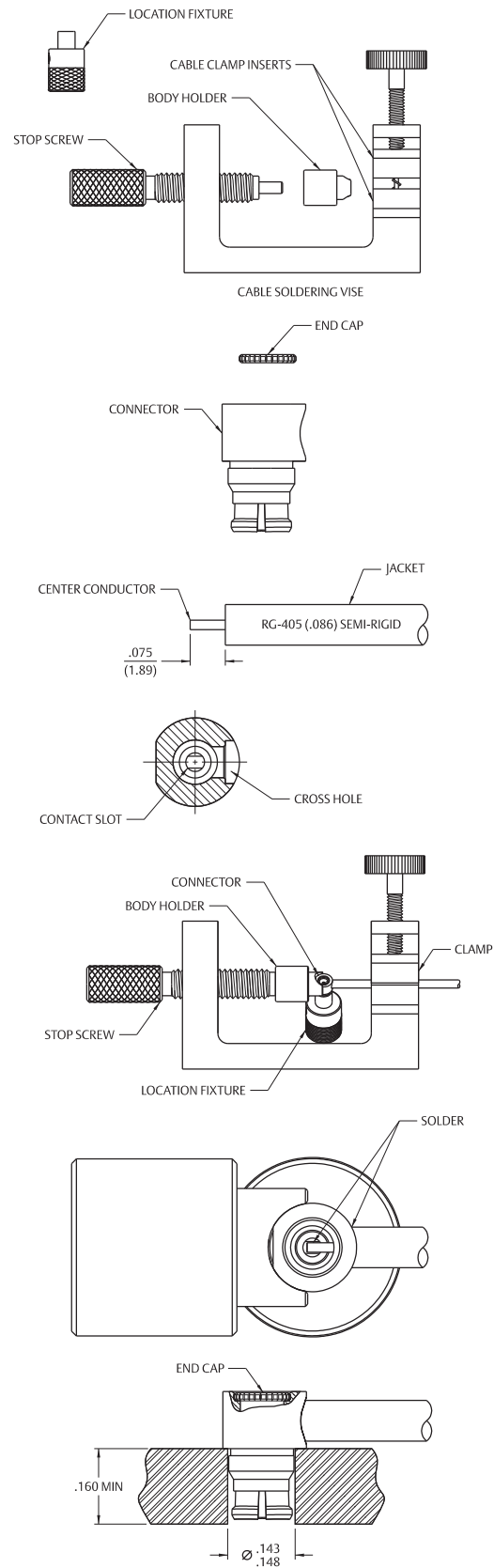

Cable Group	Part Number
RG-405, .086 Semi-Rigid	127-0693-101

Tool	Part Number
Cable Vise	140-0000-962
Stop Screw	140-0000-981
Clamp Inserts	140-0000-964
Body Holder	127-0000-904
Interface Location Fixture	127-0000-903



# ASSEMBLY INSTRUCTIONS

## SMP Hermetic Seal Installation

1. Prepare housing panel per figure 2 as shown on page 7.
2. Install solder ring on hermetic seal as shown.  
Recommended ring size is .103 (2.62) ID x .128 (3.25) OD x .015 (0.38) Thick.
3. Solder in place as shown.

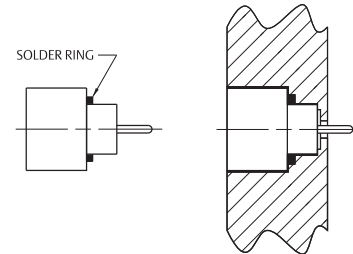
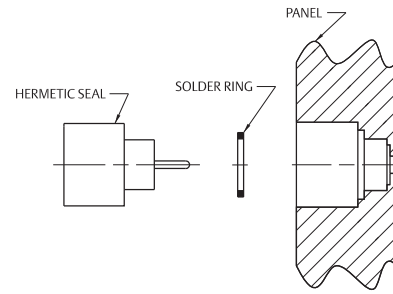

Interface	Part Number
Full Detent	127-0711-601
Limited Detent	127-1711-601
Smooth Bore	127-2711-601

## SMP Shroud Installation

1. Install appropriate assembly tool into shroud as shown.
2. While holding tool in place, align flange mount with mounting holes in panel. Install fasteners and torque to 6-8 in/lbs.

Shroud Part Number	Tool Part Number
127-0701-602	127-0000-905
127-1701-602	127-0000-906
127-2701-602	127-0000-905
127-3701-602	127-0000-905

