

SERPAC 1312AA (exploded isometric)

Electronic Enclosures

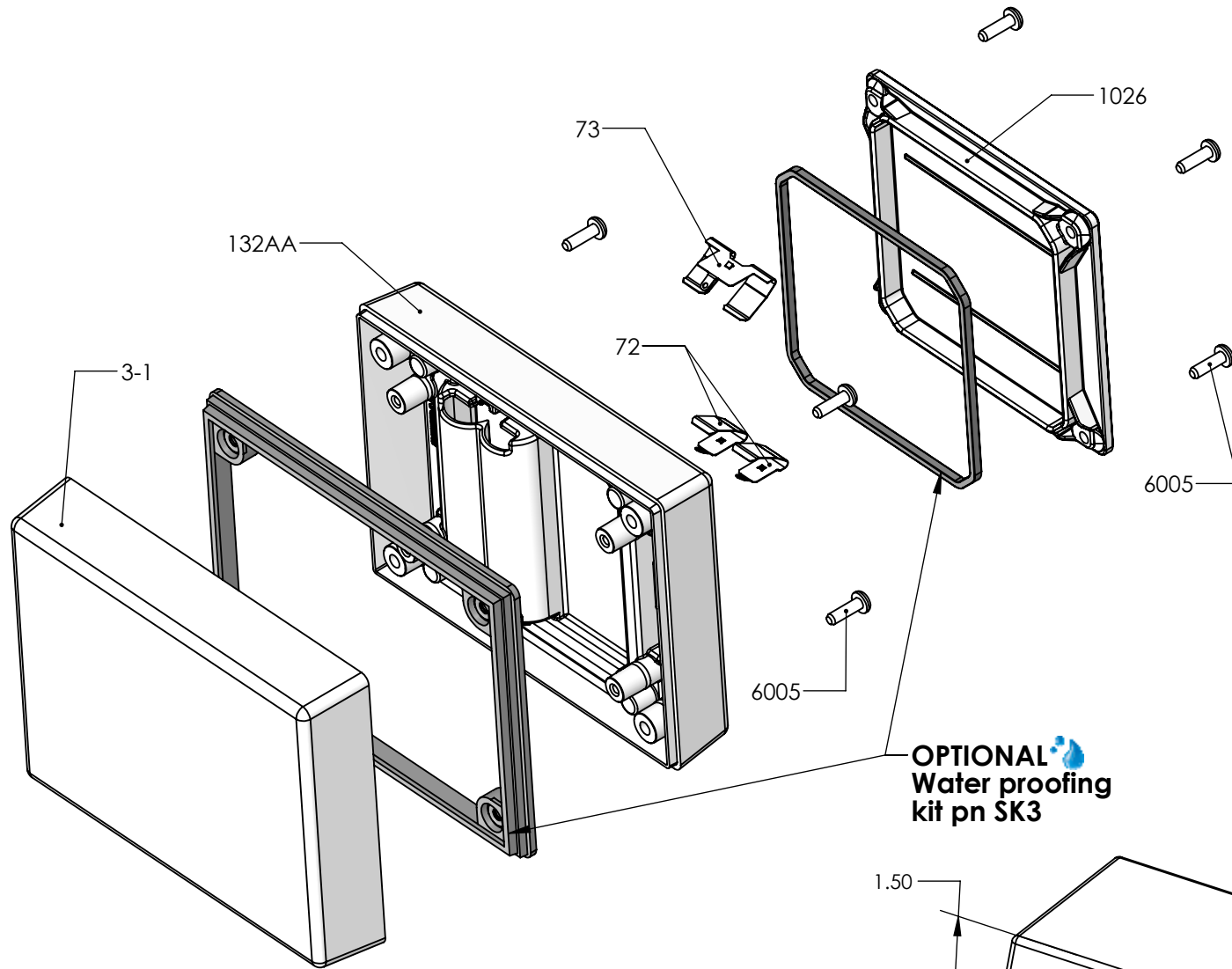

OPTIONAL
Water proofing
kit pn SK3

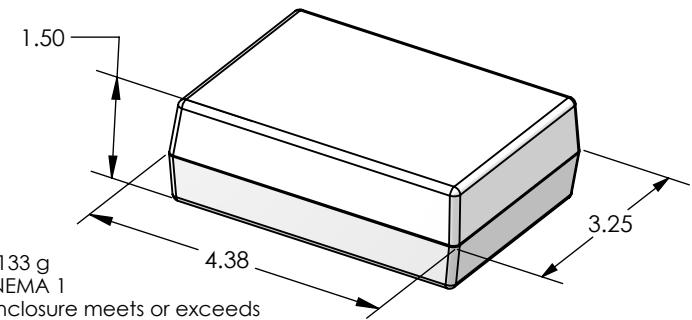

PART NO.	DESCRIPTION (Included)	ACCESSORIES (Optional)	
3-1	Top	PART NO.	DESCRIPTION
132AA	2AA Bottom	50	Non-skid Feet
1026	Access Door	SK3	Seal Kit for 13X
6005	#4X3/8" Self-Tapping Screw (8)		
73	Double Battery Contact		
72	Single Battery Contact (2)		

Notes: Enclosure weight .29 lb / 133 g
 1) Enclosure meets or exceeds IP40 and NEMA 1
 2) When used with PS13 and ACO1 the enclosure meets or exceeds IP 67 and NEMA 4X, 12 and 13 MIL-STD-810G 506.5 (.02 lb / 10 g)
 3) Circuit Board drawings can be download at:
<https://serpac.com/accessories/circuit-boards.aspx>
 4) All components are RoHS Compliant.

ALL DIMENSIONS ARE ± .010" 11/17/2021 (1 of 3)
 2009 Wright Ave. La Verne, CA 91750
 Ph. (626) 331-0517 Fx. (626) 331-8584 serpac.com

SERPAC 1312AA

Electronic Enclosures

