

SMA COAXIAL CONNECTORS

All connectors listed, unless otherwise noted, are Commercial Grade construction, gold-plated brass bodies with 50 μ " gold contacts. All insulators are teflon. All other parameters are equal to Mil Standard construction.

Mil Standard connectors, i.e. Stainless Steel body, available upon request as per material specifications listed in Material section on preceding page.

All dimensions in millimeters and [inches].

C A B L E G R O U P L E G E N D					
01	58/ 58A/ 58C/ 141/ 303/ LMR195™/ B7806A	06A	179/ U DOUBLE BRAIDED	09	B8227/ 89207
01A	55/ 142/ 223/ 400	07	8/ 8A/ 213/ 393	10	.141 SEMI-RIGID/ 402/U
01B	LMR200™/ B7807A	07A	214	11	.085 SEMI-RIGID/ 405/U
02	58 PLENUM/THINNET/ 122U/ B88240/ B89907	07B	8X/ LMR240™/ B7808A	12	.250 SEMI-RIGID
03	59/ 62/ 140/ 210	07C	B9913/ LMR400™/ B7810A/ B8214	13	.047 SEMI-RIGID/ B1674A
03A	59/ U-20AWG	07D	B89913	14	178/ 196
04	59/ U PLENUM	07E	11	15	B8281/ B9231/ B9141
04A	59/ U PLENUM-20AWG	07F	11/ U-14AWG/ B8213/ B9292/ B7731/ B1859A	15A	B88281
05	174/ 188A/ 316/ B7805A	08	6/ 143/ 212	16	180/ 195/ 122/ B8218/ B1865A/ B1855
05A	316/ U DOUBLE BRAIDED	08A	B1694A/ B9248	17	LMR600™
06	179/ 187/ B9221	08B	6 PLENUM/ B1695A	18	AT&T734A/ B1505A
				19	AT&T735A/ B735A1

DIRECT SOLDER FOR SEMI-RIGID .047", .085" AND .141" CABLE

STRAIGHT CABLE PLUG — CABLE CENTER CONTACT

P.N.	Cable Group	Finish	Insulation	Impedance	Crimp Tool
132100	10	Gold	N/A	50	N/A
132100SS	10	S/S STAINLESS STEEL	N/A	50	N/A
132266	10	Gold SHORT PROFILE	N/A	50	N/A
132266SS	10	S/S STAINLESS STEEL, SHORT PROFILE	N/A	50	N/A

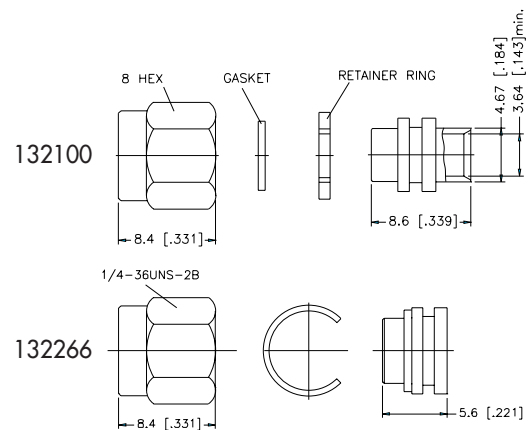
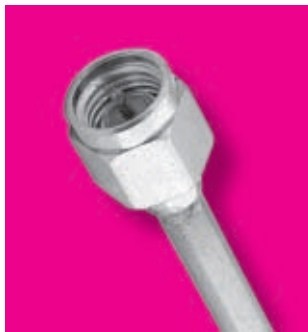

STRAIGHT CABLE PLUG — WITH CONTACT

P.N.	Cable Group	Finish	Insulation	Impedance	Crimp Tool
132101	11	Gold	Teflon	50	N/A
132102	10	Gold	Teflon	50	N/A
132200	10	Gold STAINLESS STEEL	Teflon	50	N/A
132248	11	Gold STAINLESS STEEL NUT	Teflon	50	N/A
132296	12	Gold	Teflon	50	N/A
132249	13	Gold	Teflon	50	N/A

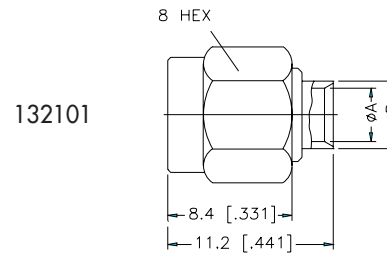

132290	10	Gold CONTACT IN BODY	Teflon	50	N/A
132294	11	Gold CONTACT IN BODY	Teflon	50	N/A
132290-10	10	Gold EXTENDED BODY	Teflon	50	N/A
132294-10	11	Gold EXTENDED BODY	Teflon	50	N/A

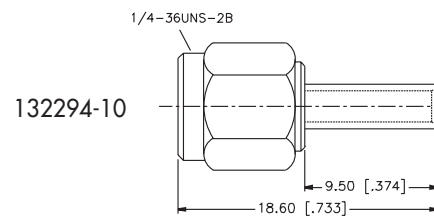
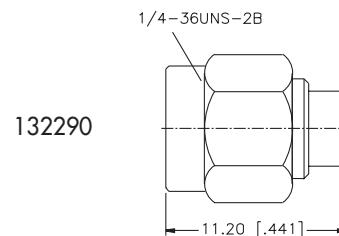

Cable: .047" Cable, A = 1.24 mm [.049"] min,
 B = 3.0 mm [.118"] min
 .085" Cable, A = 2.2 mm [.087"] min,
 B = 3.0 mm [.118"] min
 .141" Cable, A = 3.6 mm [.142"] min,
 B = 4.6 mm [.181"] min

For Reverse Polarized connectors, add RP to standard part number. Contact Connex marketing for availability.
 For Reverse Threaded connectors, add RT to standard part number. Contact Connex marketing for availability.
 For Crimp Tool information, see page 183.

DIRECT SOLDER FOR SEMI-RIGID .047", .085" AND .141" CABLE

For Cable Group Legend, see page 27

STRAIGHT CABLE PLUG — WITH CONTACT — TORQUE NUT

P.N.	Cable Group	Finish	Insulation	Impedance	Crimp Tool
------	-------------	--------	------------	-----------	------------

132179	10	Gold	Teflon	50	N/A
STAINLESS STEEL NUT					

132188	11	Gold	Teflon	50	N/A
STAINLESS STEEL NUT					

Cable: .047" Cable, A = 1.24 mm [.049"] min,
B = 3.0 mm [.118"] min

.085" Cable, A = 2.2 mm [.087"] min,
B = 3.0 mm [.118"] min

.141" Cable, A = 3.6 mm [.142"] min,
B = 4.6 mm [.181"] min

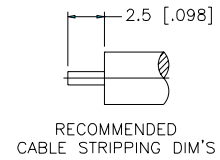
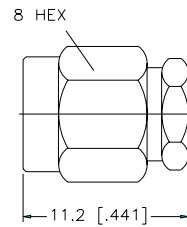
**RIGHT ANGLE CABLE PLUG DC — 12.4 GHz**

P.N.	Cable Group	Finish	Insulation	Impedance	Crimp Tool
------	-------------	--------	------------	-----------	------------

132112	10	Gold	Teflon	50	N/A
--------	----	------	--------	----	-----

132201	10	Gold	Teflon	50	N/A
STAINLESS STEEL NUT					

132111	11	Gold	Teflon	50	N/A
132250	13	Gold	Teflon	50	N/A

Cable: .047" Cable, A = 1.24 mm [.049"] min,
B = 3.0 mm [.118"] min

.085" Cable, A = 2.2 mm [.087"] min,
B = 3.0 mm [.118"] min

.141" Cable, A = 3.6 mm [.142"] min,
B = 4.6 mm [.181"] min

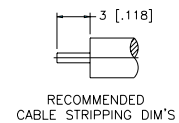
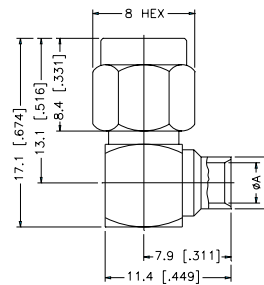
**STRAIGHT CABLE JACK**

P.N.	Cable Group	Finish	Insulation	Impedance	Crimp Tool
------	-------------	--------	------------	-----------	------------

132104	10	Gold	Teflon	50	N/A
132103	11	Gold	Teflon	50	N/A
132257	13	Gold	Teflon	50	N/A

Cable: .047" Cable, A = 1.24 mm [.049"] min,
B = 3.0 mm [.118"] min

.085" Cable, A = 2.2 mm [.087"] min,
B = 3.0 mm [.118"] min

.141" Cable, A = 3.6 mm [.142"] min,
B = 4.6 mm [.181"] min

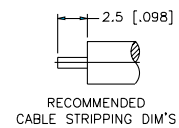
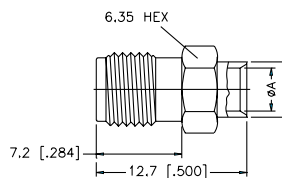
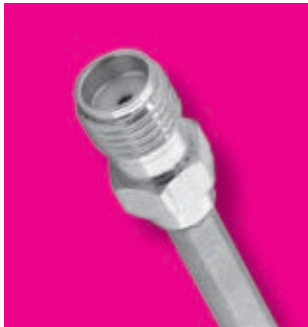
**BULKHEAD FEEDTHROUGH CABLE JACK — O-RING SEAL**

P.N.	Cable Group	Finish	Insulation	Impedance	Crimp Tool
------	-------------	--------	------------	-----------	------------

132106	10	Gold	Teflon	50	N/A
132105	11	Gold	Teflon	50	N/A
132251	13	Gold	Teflon	50	N/A

132273	13	Gold	Teflon	50	N/A
EXTENDED BODY .725"					

Cable: .047" Cable, A = 1.24 mm [.049"] min,
B = 3.0 mm [.118"] min

.085" Cable, A = 2.2 mm [.087"] min,
B = 3.0 mm [.118"] min

.141" Cable, A = 3.6 mm [.142"] min,
B = 4.6 mm [.181"] min

