

SERPAC 132C4AA (exploded isometric)

Electronic Enclosures

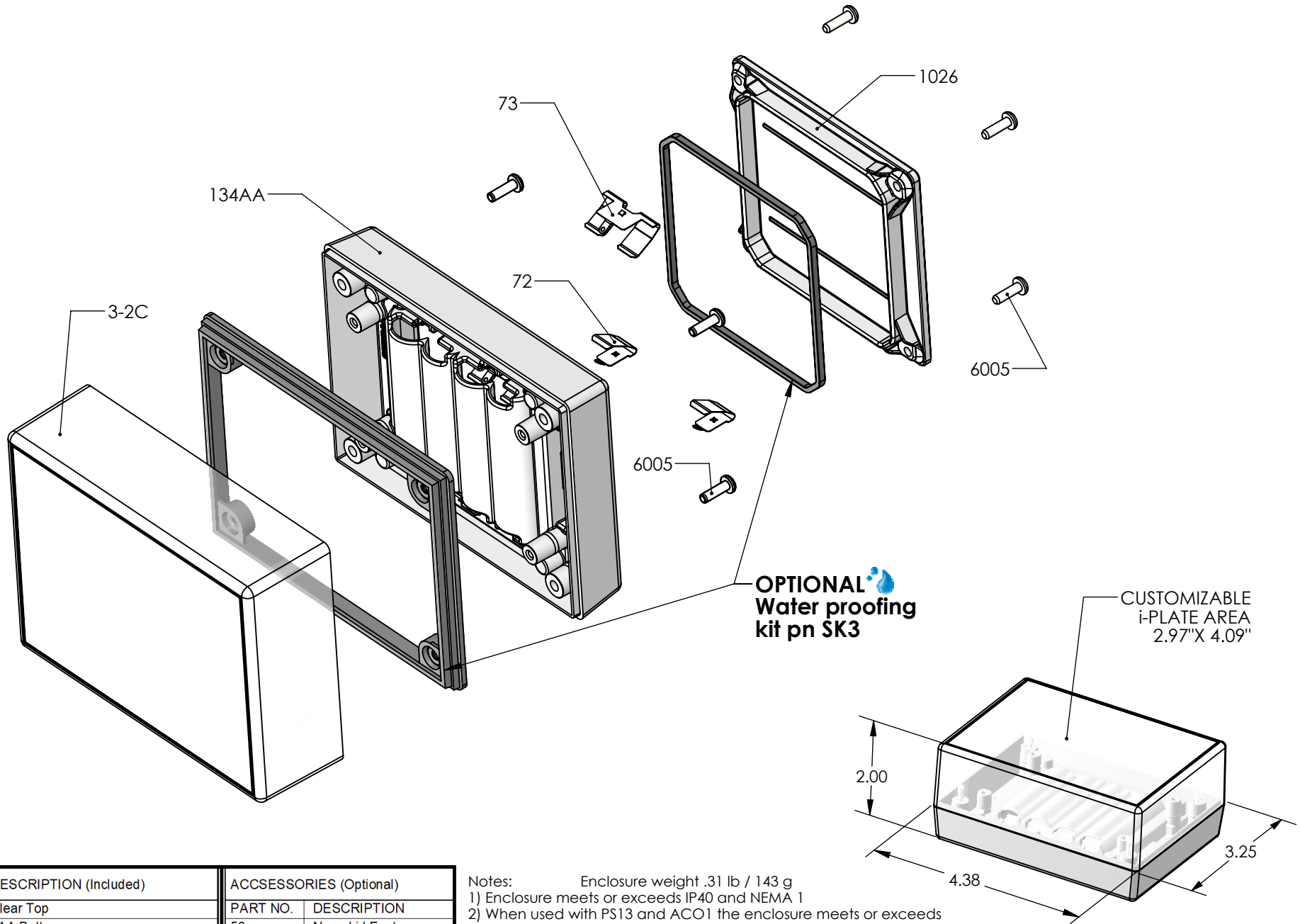

PART NO.	DESCRIPTION (Included)	ACCESSORIES (Optional)
3-2C	Clear Top	PART NO. DESCRIPTION
134AA	4AA Bottom	50 Non-skid Feet
1026	Access Door	SK3 Seal Kit for 13X
6005	#4X3/8" Self-Tapping Screw (8)	
73	Double Battery Contact (3)	
72	Single Battery Contact (2)	

Notes: Enclosure weight .31 lb / 143 g
 1) Enclosure meets or exceeds IP40 and NEMA 1
 2) When used with PS13 and ACO1 the enclosure meets or exceeds IP 67 and NEMA 4X, 12 and 13 MIL-STD-810G 506.5 (.02 lb / 10 g)
 3) Circuit Board drawings can be download at:
<https://serpac.com/accessories/circuit-boards.aspx>
 4) All components are RoHS Compliant.

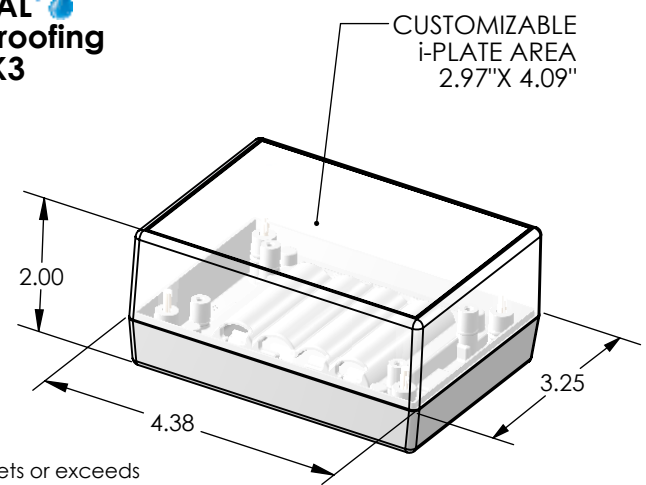

SERPAC 132C4AA

Electronic Enclosures

