

# SERPAC 132RCAC (exploded isometric)

Electronic Enclosures

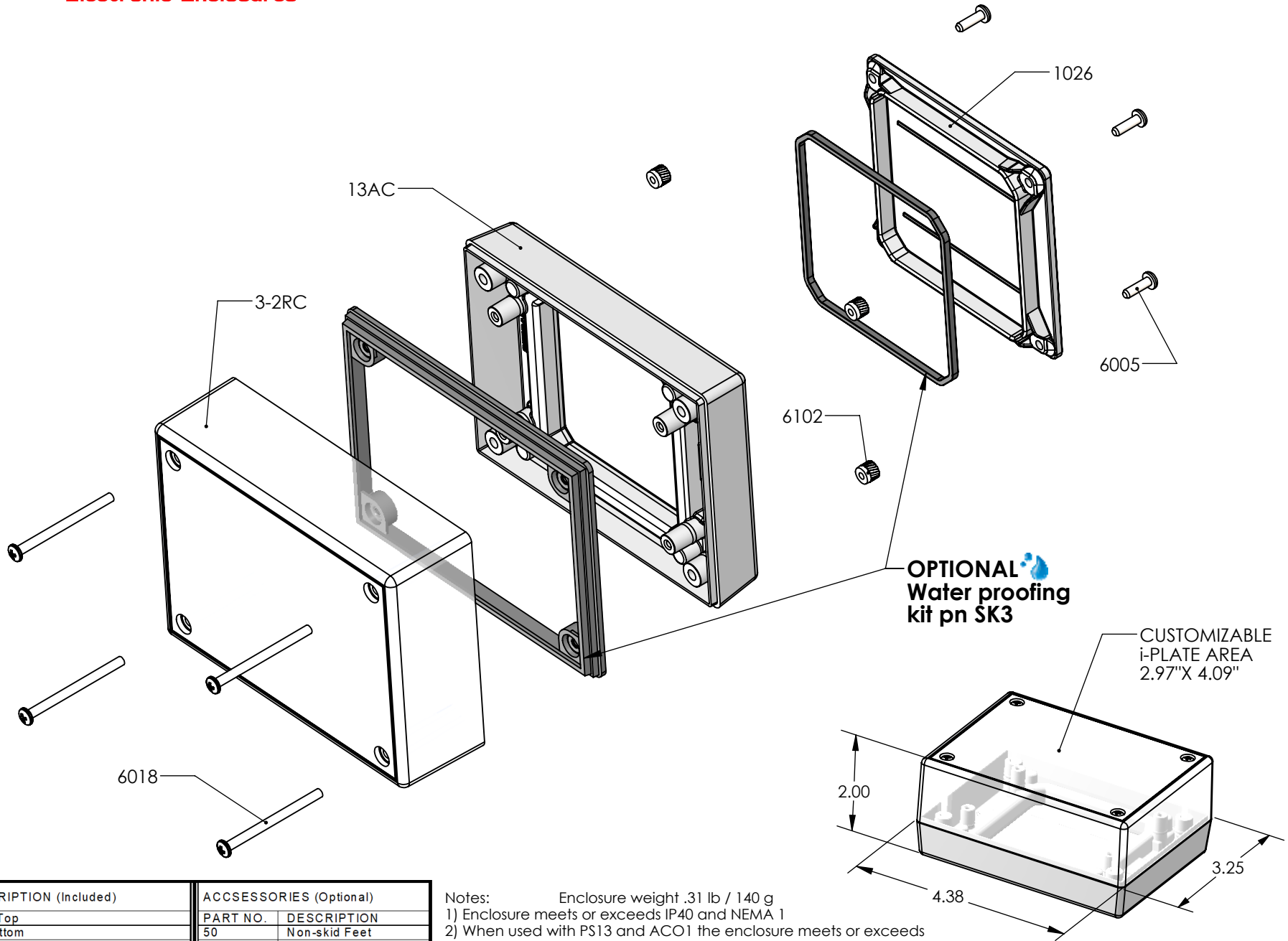

**OPTIONAL**  
Water proofing  
kit pn SK3

CUSTOMIZABLE  
i-PLATE AREA  
2.97"X 4.09"

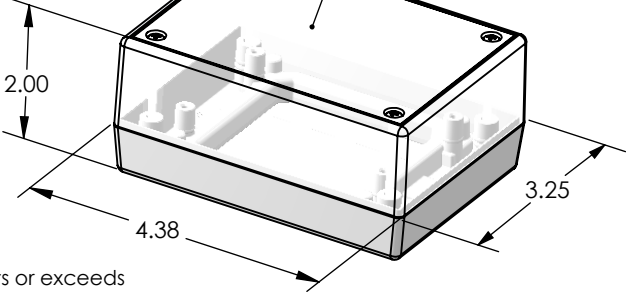

PART NO.	DESCRIPTION (Included)	ACCESSORIES (Optional)	
3-2RC	Clear Top	PART NO.	DESCRIPTION
13AC	AC Bottom	50	Non-skid Feet
1026	Access Door	SK3	Seal Kit for 13X
6005	#4X3/8" Self-Tapping Screw (4)		
6018	4-40 Screw (4)		
6102	Threaded Insert (4)		

- Notes:
- 1) Enclosure weight .31 lb / 140 g
  - 2) When used with PS13 and ACO1 the enclosure meets or exceeds IP 67 and NEMA 4X, 12 and 13 MIL-STD-810G 506.5 (.02 lb / 10 g)
  - 3) Circuit Board drawings can be download at:  
<https://serpac.com/accessories/circuit-boards.aspx>
  - 4) All components are RoHS Compliant.

# SERPAC 132RCAC

Electronic Enclosures

