

SERPAC 133AC (exploded isometric)

Electronic Enclosures

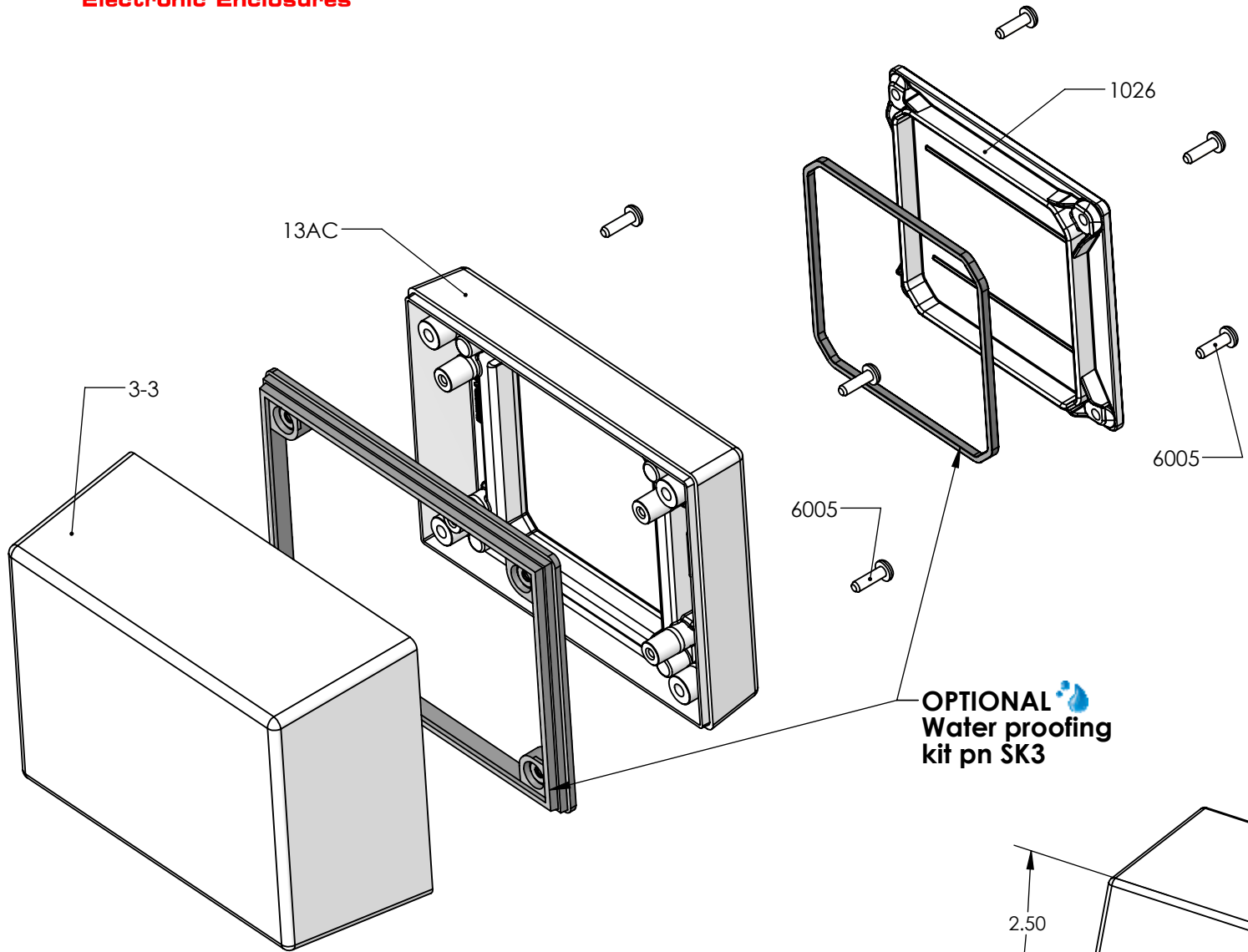

OPTIONAL
Water proofing
kit pn SK3

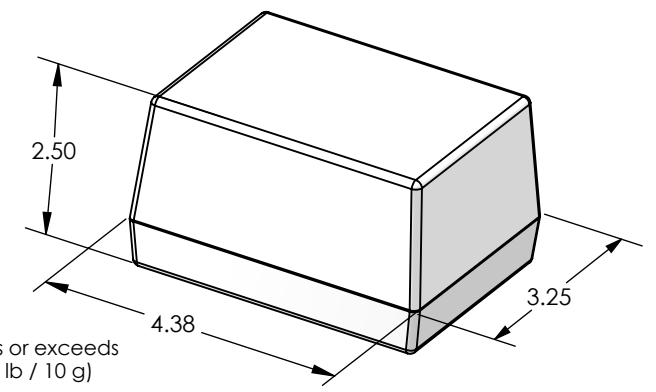

PART NO.	DESCRIPTION (Included)	ACCESSORIES (Optional)	
3-3	Top	PART NO.	DESCRIPTION
13AC	AC Bottom	50	Non-skid Feet
1026	Access Door	SK3	Seal Kit for 13X
6005	#4X3/8" Self-Tapping Screw (8)		

- Notes: Enclosure weight .30 lb / 136 g
- 1) Enclosure meets or exceeds IP40 and NEMA 1
 - 2) When used with PS13 and ACO1 the enclosure meets or exceeds IP 67 and NEMA 4X, 12 and 13 MIL-STD-810G 506.5 (.02 lb / 10 g)
 - 3) Circuit Board drawings can be download at:
<https://serpac.com/accessories/circuit-boards.aspx>
 - 4) All components are RoHS Compliant.

SERPAC 133AC

Electronic Enclosures

