

SYMBOL DEFINITION		
A DIMENSION WITHOUT AN INSPECTION REPORT SYMBOL  DOES NOT REQUIRE INSPECTION. IT MAY BE CONTROLLED ON THE INDIVIDUAL COMPONENT DRAWING.	TOTAL NO OF INSPECTIONS REQUIRED	3
	LAST NO. USED	3

MISSING SYMBOLS
NO MISSING SYMBOL NUMBER

DWG STATUS					ZONE	REVISION HISTORY			
DATE	STG	REV	N/P	CHG		AUTH	DR	APVD 1	APVD 2
14AP09	R	01	-	-		WAS PE190091 AND RELEASED			
08DE09	R	02	-	-		DIMENSION #2 WAS 8			
10MR14	R	02	AA	-		UPDATED MAT'L CALLOUT			

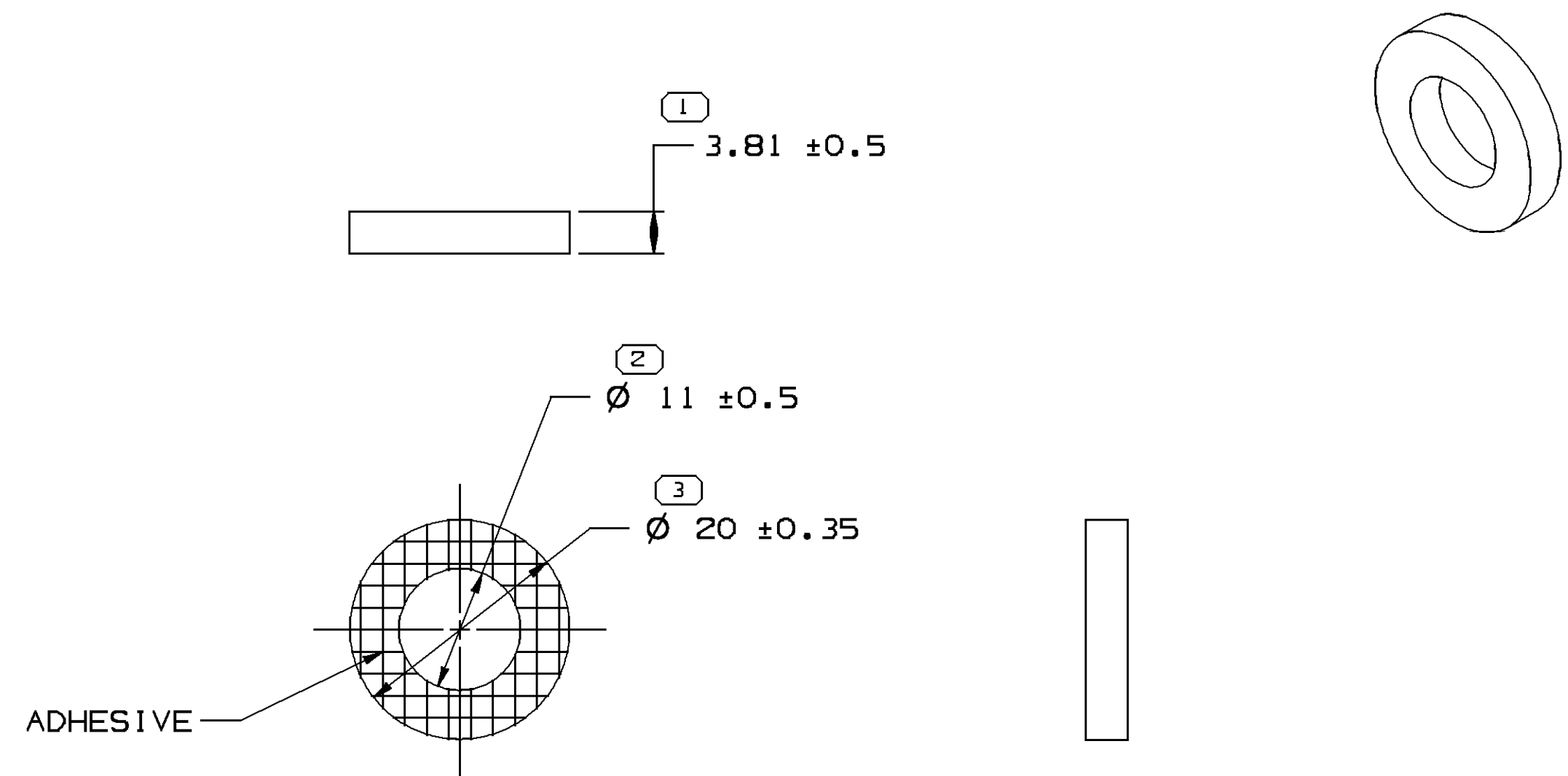

NOTES

- UNLESS OTHERWISE SPECIFIED AND/OR INDICATED:
DIMENSIONS ARE TO FACE OF VIEW SHOWN AND AUTOMATICALLY ROUNDED BY COMPUTER FOR INSPECTION (SEE MATH MODEL FOR PRECISE DIMENSIONS). FOR ALL OTHER DIMENSIONS NOT SHOWN BUT REQUIRED FOR TOOL BUILD, SEE MATH MODEL FOR PRECISE TOOL PATH DATA.
- THIS PART USED IN ASSEMBLY 13754701.
- THIS PART ACCEPTS THE FOLLOWING COMPONENTS OR EQUIVALENT:
CLIP 13746617
- GASKET MUST ADHERE TO MYLAR SHEET BUT NOT TEAR ON REMOVAL.
- THE GASKET END WITH THE LEAST AMOUNT OF ADHESIVE MUST EXHIBIT A MINIMUM AVERAGE PULL VALUE OF 6.7N (1.5 LB.) WITH NO TEST VALUE LESS THAN 4.5N (1.0 LB.) WHEN SUBJECTED TO A 45° PEEL TEST FROM A CLEAN ACRYLIC PLATE. THE GASKET END TESTED IS TO BE HELD UNDER 50% COMPRESSION FOR 1.0 MIN. PRIOR TO TESTING.

3 PROCESS SENSITIVE DIMENSION
DIMENSIONS ENCLOSED IN () INDICATE REFERENCE DIMENSIONS AND NO TOLERANCE LIMITS ARE ESTABLISHED

DIMENSIONAL RANGE (MM)		CHART E1	
FROM	TO		
> 0	> 20	> 30	> 70
> 20	> 30	> 70	> 100
> 30	> 70	> 100	> 150
> 70	> 100	> 150	> 200
> 100	> 150	> 200	> 250
> 150	> 200	> 250	> 300
> 200	> 250	> 300	> 400
TOLERANCE UNLESS OTHERWISE SPECIFIED			
±0.15	±0.2	±0.3	±0.4
±0.5	±0.6	±0.8	±1
±1.2	ANGULAR TOLERANCE ±2°		

A LINE DRAWN THROUGH A PART NUMBER INDICATES THAT PHYSICAL PARTS ARE NOT AVAILABLE FOR ORDERING.
PART NUMBERS THAT DO NOT HAVE A LINE PRESENT INDICATE THAT PHYSICAL PARTS ARE AVAILABLE FOR ORDERING.
CONTACT DELPHI SALES TO ASSURE AVAILABILITY OF PARTS.

DWG TYPE: PART DRAWING

STYLE:



VOLUME (CM³): 0.835 DISTR CODE: D

UNLESS OTHERWISE SPECIFIED
THIS DOCUMENT IS IN ACCORDANCE WITH ASME Y14.5M-1994 AS AMENDED BY THE GM GLOBAL DIMENSIONING AND TOLERANCING ADDENDUM-2001. SEPARATE PATTERNS OF FEATURES MAY BE OAGD SEPARATELY REGARDLESS OF DATUM REFERENCES.

ALL DIMENSIONS ARE IN MILLIMETERS

REFERENCE: 12077937

THIRD ANGLE PROJECTION DO NOT SCALE USE MATH DATA

DELPHI
DELPHI PACKARD ELECTRICAL/ELECTRONIC ARCHITECTURE
WARREN, OH
COPYRIGHT 2009 DELPHI CORPORATION AND/OR ITS AFFILIATES. ALL RIGHTS RESERVED.
REVISED 2014
THIS DRAWING IS THE PROPERTY OF DELPHI CORPORATION AND CONTAINS DELPHI CONFIDENTIAL INFORMATION. THE REPRODUCTION, DISTRIBUTION AND UTILIZATION OF THIS DOCUMENT OR ITS RELATED CAD MATH DATA, AS WELL AS COMMUNICATION OF ANY CONTENT TO OTHERS, WITHOUT EXPRESS AUTHORIZATION, IS PROHIBITED.

DR	DATE
APVD1 J.PALOMO	14AP09
APVD2 ELIAS VAZQUEZ V.	14AP09
APVD3 J.PALOMO	14AP09
APVD4	
APVD5	

SUBSTANCES OF CONCERN AND RECYCLED CONTENT PER DELPHI 10949001

MATERIAL: FOAM - EDPM WITH ADHESIVE

DRAWING NAME: SEAL GASKET CLIP

DRAWING NUMBER: 13754700

SIZE	SCALE	FRAME NO	SHEET NO	STG	REV	N/P
A2	2:1	1 OF 1	1 OF 1	R	02	AA