

Description

Single pole press-to-reset thermal circuit breaker with extremely fast overload switching performance (R-type TO CBE to EN 60934). Single hole threadneck, PCB or integral mounting with a choice of designs. Miniaturised construction minimises PCB real estate required. PCB mounting or integral mounting. Largely temperature-insensitive.

Typical applications

Motors, transformers, solenoids, PCBs, hand-held machines, appliances, instrumentation.

Ordering information

Type No.	
1410	single pole circuit breaker
Configuration	
L	integral mounting or PCB mounting
Mounting	
1	footprint 16.3x4.6
4	footprint 17.5x4.6
Number of poles	
1	1 pole, thermally protected
Hardware	
0	without
Terminal design	
L1	solder pins 1.8x0.8 silver-plated (-L1 only)
P3	blade terminals DIN 46244-A4.8-0.5 silver-plated (only -L4)
P4	blade terminals DIN 46244-A4.8-0.8 silver-plated (only -L4)
Characteristic curve	
F1	fast acting
Actuator	
S	reset button (1410-L1)
E	round reset slide (1410-L4)
Actuator colour	
01	black (for -L1)
03	white-yellow (for -L4)
04	red (for -L4)
Current ratings	
0.63...10 A	
1410 - L 1 1 0 - L1 F1 - S 01 - 0.8 A ordering example	

*mounting hardware bulk shipped

Standard current ratings and typical internal resistance values

Current rating (A)	Internal resistance (Ω)	Current rating (A)	Internal resistance (Ω)
0.63	1.8	3.15	< 0.12
0.8	1.7	4	< 0.1
1	1.3	5	< 0.1
1.5	< 1	6.3	< 0.1
1.8	< 1	8	< 0.1
2	< 1	10	< 0.1
2.5	< 0.15		

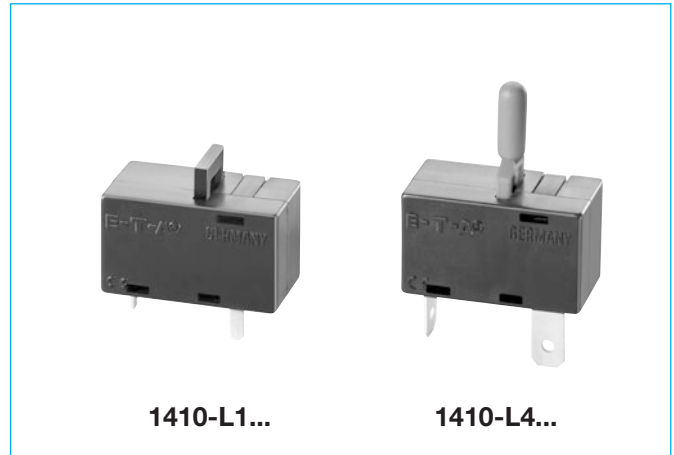

Technical data

For further details please see chapter: Technical Information

Voltage rating	AC 240 V; DC 28 V (UL: AC 250 V; DC 50 V)	
Current rating range 1-2	0.63...10 A	
Auxiliary circuit 1-3	0.2 x I _N max. 1 A, AC 250 V style -L2 and -G1 only	
Typical life	AC 240 V: 0.63...2.25 A 500 operations at 2 x I _N , inductive 2.5...10 A 500 operations at 2 x I _N , resistive DC 50 V: 0.63...2.25 A 500 operations at 2 x I _N , inductive DC 28 V: 2.5...10 A 500 operations at 2 x I _N , inductive	
Ambient temperature	-20...+100 °C (-4...+212 °F)	
Insulation co-ordination (IEC 60664 and 60664 A)	rated impulse withstand voltage 2.5 kV	pollution degree 2 reinforced insulation in operating area
Dielectric strength (IEC 60664 and 60664 A)	test voltage AC 1,500 V	operating area
Insulation resistance	> 100 MΩ (DC 500 V)	
Interrupting capacity I _{cn} (o-o-o)	0.63...2 A 2.5...8 A 10 A 3.15...10 A	12 x I _N 8 x I _N , AC max. 50 A 6 x I _N , AC 10 x I _N , DC
Interrupting capacity (UL 1077)	0.63...10 A 0.63...10 A	2,000 A AC 250 V 200 A DC 50 V
Degree of protection (IEC 60529/DIN 40050)	operating area IP40 terminal area IP00	
Vibration	8 g (57-500 Hz) ±0.61 mm (10-57 Hz), to IEC 60068-2-6, test Fc, 10 frequency cycles/axis	
Shock	20 g (11 ms) to IEC 60068-2-27, test Ea	
Corrosion	48 hours at 5 % salt mist, to IEC 60068-2-11, test Ka	
Humidity	96 hours at 95 % RH to IEC 60068-2-3, test Ca	
Mass	approx. 5 g	

Approvals

Authority	Voltage rating	Current ratings
VDE	AC 240 V	0.63...10 A
	DC 50 V	0.63...2 A
	DC 28 V	2.5...10 A
UL, CSA	AC 250 V; DC 50 V	0.63...10 A

Dimensions

1410-L110-L1F1-S01

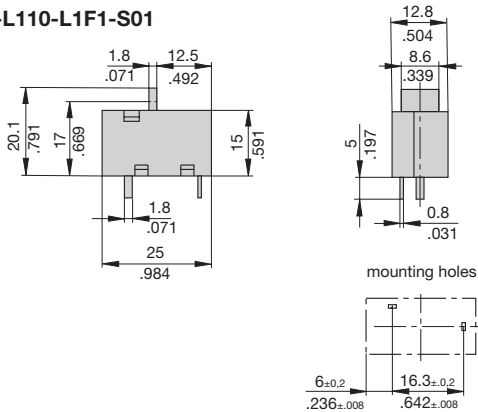

1410-L410-P3F1-E...

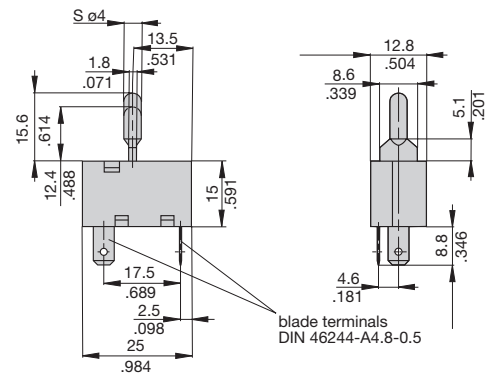

1410-L410-P4F1-E...

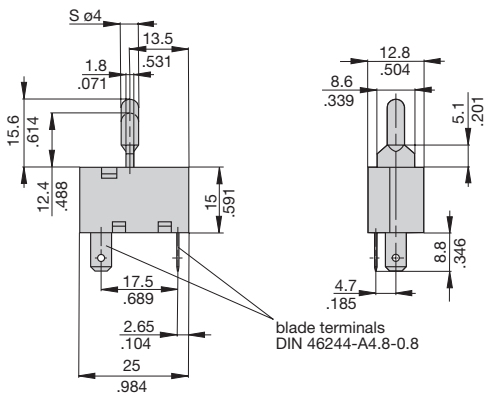

Internal connection diagrams

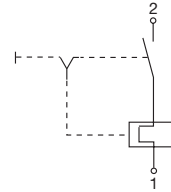

Typical time/current characteristics at +23°C/+73.4°F

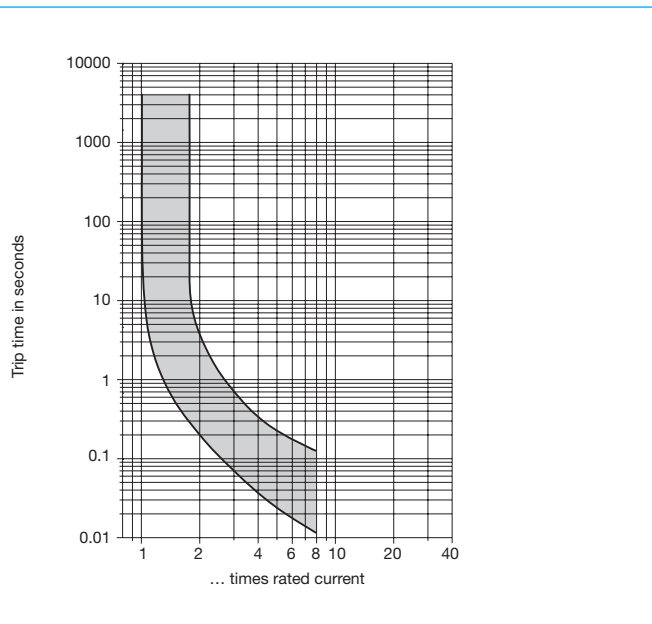

Installation drawings

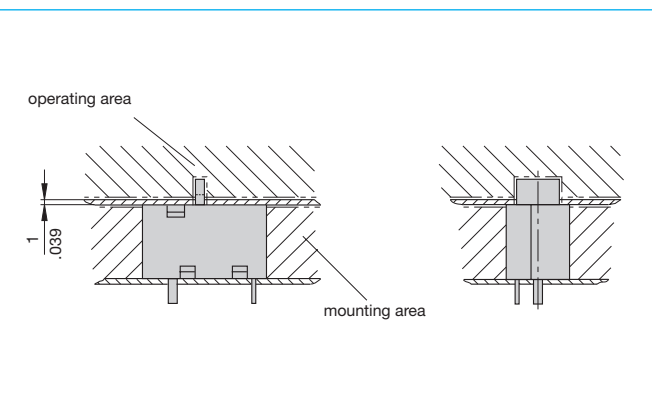

This is a metric design and millimeter dimensions take precedence ($\frac{\text{mm}}{\text{inch}}$)

All dimensions without tolerances are for reference only. In the interest of improved design, performance and cost effectiveness the right to make changes in these specifications without notice is reserved. Product markings may not be exactly as the ordering codes. Errors and omissions excepted.

Description

Single pole press-to-reset thermal circuit breaker with extremely fast overload switching performance (R-type TO CBE to EN 60934). Single hole threadneck, PCB or integral mounting with a choice of designs. Miniaturised construction minimises PCB real estate required. Type 1410-L2 and 1410-G1 versions feature changeover contacts suitable for providing status output signals. Largely temperature-insensitive.

Typical applications

Motors, transformers, solenoids, PCBs, hand-held machines, appliances, instrumentation.

Ordering information

Type No.	1410	single pole circuit breaker
Configuration	L	PCB mounting or integral mounting
	G	threadneck panel mounting or PCB mounting
Mounting	1	threadneck 3/8-27UNS-2A (1410-G)
	2	PCB 10.15x7.62 (1410-L)
	3	PCB 10.15 without shunt terminal (1410-L)
Number of poles	1	1 pole, thermally protected
Hardware	0	without
	1	with hexnut and knurled nut (only 1410-G) > 5 pcs hexnut and knurled nut bulk shipped
	2	without hexnut and knurled nut and without shunt terminal (only 1410-G)
	4	with hexnut and knurled nut, without shunt terminal (only 1410-G)
	8	with actuator guard and marking CB. (only 1410-G)
Terminal design	L2	solder pins 1x0.8 silver-plated
	P2	blade terminals DIN 46244-A2.8-0.8 silver-plated (only -G)
	P3	blade terminals DIN 46244-A4.8-0.5 silver-plated (only -G)
Characteristic curve	F1	fast acting
Actuator	B	flat reset-slide (only 1410-G)
	S	reset slide/button
Actuator colour	01	black (for -G1..)
	02	white (for -L2..)
	04	red (for 1410-G.-...B)
Current ratings		0.63...10 A

1410 - L 2 1 0 - L2 F1 - S 02 - 0.8 A ordering example

*mounting hardware bulk shipped

Standard current ratings and typical internal resistance values

Current rating (A)	Internal resistance (Ω)	Current rating (A)	Internal resistance (Ω)
0.63	1.8	3.15	< 0.12
0.8	1.7	4	< 0.1
1	1.3	5	< 0.1
1.5	< 1	6.3	< 0.1
1.8	< 1	8	< 0.1
2	< 1	10	< 0.1
2.5	< 0.15		

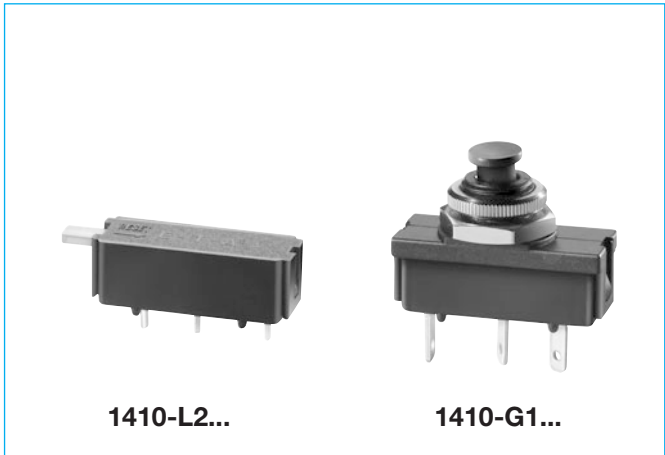

Technical data

For further details please see chapter: Technical Information

Voltage rating	AC 240 V; DC 28 V (UL: AC 250 V; DC 50 V)
Current rating range 1-2	0.63...10 A
Auxiliary circuit 1-3	0.2 x I _N max. 1 A, AC 250 V style -L2 and -G1 only
Typical life	AC 240 V: 0.63...2.25 A 500 operations at 2 x I _N , inductive 2.5...10 A 500 operations at 2 x I _N , resistive DC 50 V: 0.63...2.25 A 500 operations at 2 x I _N , inductive DC 28 V: 2.5...10 A 500 operations at 2 x I _N , inductive
Ambient temperature	-20...+100 °C (-4...+212 °F)
Insulation co-ordination (IEC 60664 and 60664 A)	rated impulse withstand voltage 2.5 kV pollution degree 2 reinforced insulation in operating area
Dielectric strength (IEC 60664 and 60664 A) operating area	test voltage AC 1,500 V
Insulation resistance	> 100 MΩ (DC 500 V)
Interrupting capacity I _{cn} (o-o-o)	0.63...2 A 12 x I _N 2.5...8 A 8 x I _N , AC max. 50 A 10 A 6 x I _N , AC 3.15...10 A 10 x I _N , DC
Interrupting capacity (UL 1077)	0.63...10 A 2,000 A AC 250 V 0.63...10 A 200 A DC 50 V
Degree of protection (IEC 60529/DIN 40050)	operating area IP40 terminal area IP00
Vibration	8 g (57-500 Hz) ±0.61 mm (10-57 Hz), to IEC 60068-2-6, test Fc, 10 frequency cycles/axis
Shock	20 g (11 ms) to IEC 60068-2-27, test Ea
Corrosion	48 hours at 5 % salt mist, to IEC 60068-2-11, test Ka
Humidity	96 hours at 95 % RH to IEC 60068-2-3, test Ca
Mass	approx. 5 g

Approvals

Authority	Voltage rating	Current ratings
VDE	AC 240 V DC 50 V DC 28 V	0.63...10 A 0.63...2 A 2.5...10 A
UL, CSA	AC 250 V; DC 50 V	0.63...10 A