

These drawings and specifications are the property of Microdot Inc., are issued in strict confidence and shall not be divulged, be reproduced or copied, or used as the basis for the manufacture or sale of any article without written permission of Microdot Inc.

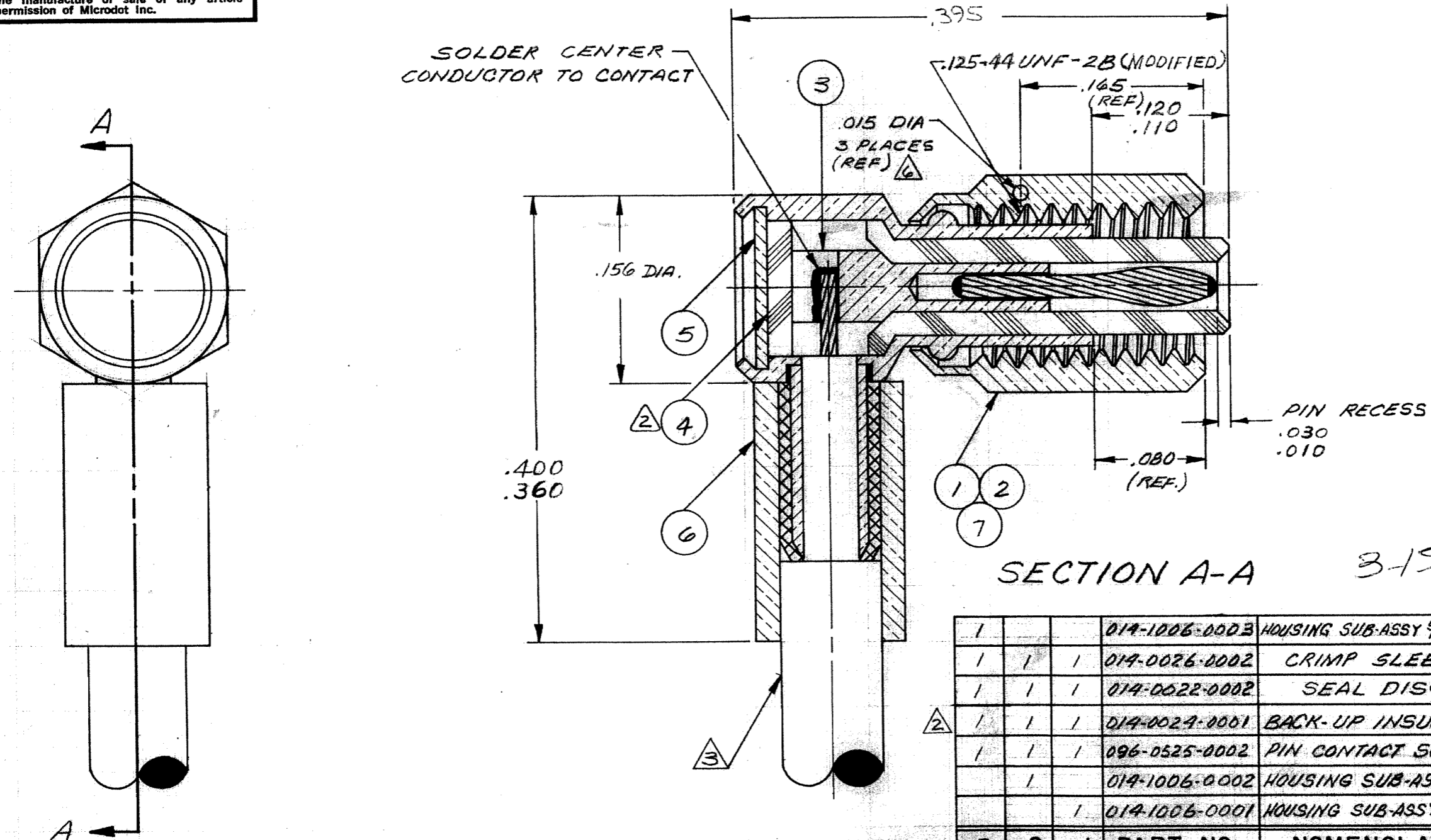

-3	-2	-1	PART NO.	NOMENCLATURE	MAT'L & SPEC	ITEM
			019-1006-0003	HOUSING SUB-ASSY $\frac{5}{32}$ HEX W/ SAFETY HOLES		7
	1	1	019-0026-0002	CRIMP SLEEVE	COPPER ALLOY	6
	1	1	019-0022-0002	SEAL DISC	BRASS-QQ-B-613	5
2	1	1	019-0029-0001	BACK-UP INSULATOR	TEFLON-L-P-403	4
	1	1	096-0525-0002	PIN CONTACT SUB-ASSY		3
	1		019-1006-0002	HOUSING SUB-ASSY $\frac{5}{32}$ KNURL		2
		1	019-1006-0001	HOUSING SUB-ASSY $\frac{5}{32}$ HEX		1

- ⑥ ON -3 ASSY ONLY (SAFETY WIRE HOLES)
- 5. MATES WITH ALL LEPPA/CON 141 SCREW-ON SERIES JACKS & RECEPTACLES.
- 4. SEE RF-ASMB-13 FOR ASSEMBLY INSTRUCTIONS. ASSEMBLY TOOL 010-0132-0000, THOMAS & BETTS P/N WT419, REQ'D
- ③ CABLE ACCEPTANCE DIMS-CENTER COND. .012 NOM DIELECTRIC .038 MAX, JACKET .081 MAX.
- ② MAY BE POTTED WITH FURANE 10F-951 OR EQUIV. IN PLACE OF ITEM 4.
- 1. ALL METALLIC PARTS ARE GOLD PLATED PER MIL-G-45204, TYPE II, GRADE C, CLASS I

NOTES: UNLESS OTHERWISE SPECIFIED

ASSEMBLY	NO REQ'D	LET	ECO	REVISION DESCRIPTION	BY	DATE	APP
		A	5304	RELEASE FOR PROD.	DM	1/17/73	
		B	6293	COMPONENT NO UPDATED	SM	4/10/73	
		C	7417	DIM CHANGE, REV 'C'	CM	7/18/73	
		D	1670	REV. LET. UPDATE 5-12-73	DM	5/23/73	
		E	1670	380 WAS 3/8, 395 WAS 3/8, .156 WAS 5/32, DEC. TOL WAS ±.010, ADD TYPE 1 GUIDE TO NOTE 1 12-30-73 UPDATE CABLE ACCEPTANCE DIMS.	MD	1/11/74	
		F	2424	.400/.360 WAS .380, .030/.010 WAS .020 (REF), .120/.110 WAS .115	EH	7/19/74	
		G	386	REV. UPDATE	ES	3/1/75	

STANDARD TOLERANCES UNLESS OTHERWISE SPECIFIED
 DEC. ± .015
 FRAC. ± 1/64
 ANGLES ± 5°
 ECCENTRICITY MAX. T.I.R. _____
 HOLE DIA. ± _____
 SURFACE ROUGHNESS _____ MICRO INCHES
 THREADS TO MIL-S-7742 COMMERCIAL TOLERANCES APPLY TO STOCK DIMENSIONS

MALCO
 A MICRODOT COMPANY, INC.
 220 PASADENA AVE., SO. PASADENA, CAL

SURFACE TREATMENT NOTED

MATERIAL NOTED

APP: [Signature]
 CHECKED BY: [Signature]
 DRAWN BY: [Signature]
 SCALE: 10/1
 WT: [Blank]
 DATE: 2/22/66
 DRAWING NUMBER: 142-0002-000* 9

RIGHT ANGLE PLUG ASSEMBLY
 PROO CODE 946
 CODE CDM